

WP9039ADAM

User's Manual

Version 1.42A

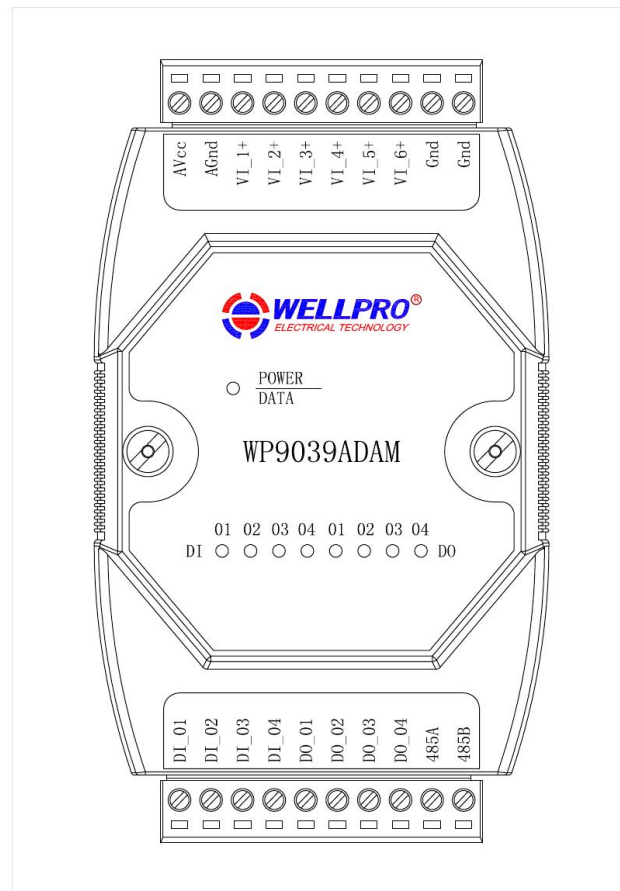

Shanghai Wellpro Electrical Technology Co., Ltd.
www.shwellpro.com

1、 Product description

- Six voltage input channel: DC0~10V
- Four optoelectronic isolation digital input channel (Low level input)
- Four optoelectronic isolation digital output channel (NPN collector output)
- RS485 MODBUS RTU standard communication protocol
- Netted with configuration software, PLC or industry touch panel
- Communication, digital input and digital output status LED
- Communication circuit designed for thunder protection and interference immunity
- Used for signal collection and control in industrial field

2、 Specification

- Analog input channel 6ch
- Analog input range DC0~10V
- Analog input accuracy ±0.02V
- Digital input channel 4ch (Low level input)
- Digital output channel 4ch (NPN collector output, 500mA)
- Working temperature -20~70°C
- External power supply DC9V~30V/2W
- Isolation protection DC1500V
- Installation method Standard DIN slide rail or screw
- Dimension 125×73×35mm

3、 Interface description

AVcc	External power supply input positive
AGnd	External power supply input negative / Power ground
VI_1+	Voltage input channel 1 positive
VI_2+	Voltage input channel 2 positive
VI_3+	Voltage input channel 3 positive
VI_4+	Voltage input channel 4 positive
VI_5+	Voltage input channel 5 positive
VI_6+	Voltage input channel 6 positive
Gnd	Voltage input channel negative / Common analog ground
Gnd	Voltage input channel negative / Common analog ground
DI_01	Digital input channel 1
DI_02	Digital input channel 2
DI_03	Digital input channel 3
DI_04	Digital input channel 4
DO_01	Digital output channel 1
DO_02	Digital output channel 2
DO_03	Digital output channel 3
DO_04	Digital output channel 4
485B	RS485 signal B-
485A	RS485 signal A+

4、 Digital / analog application diagram

4.1、 Digital input application diagram

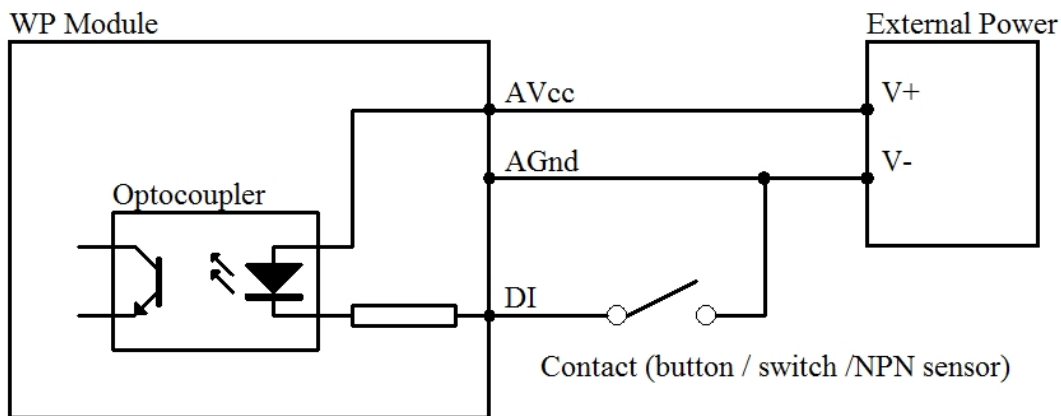

4.2. Digital output application diagram

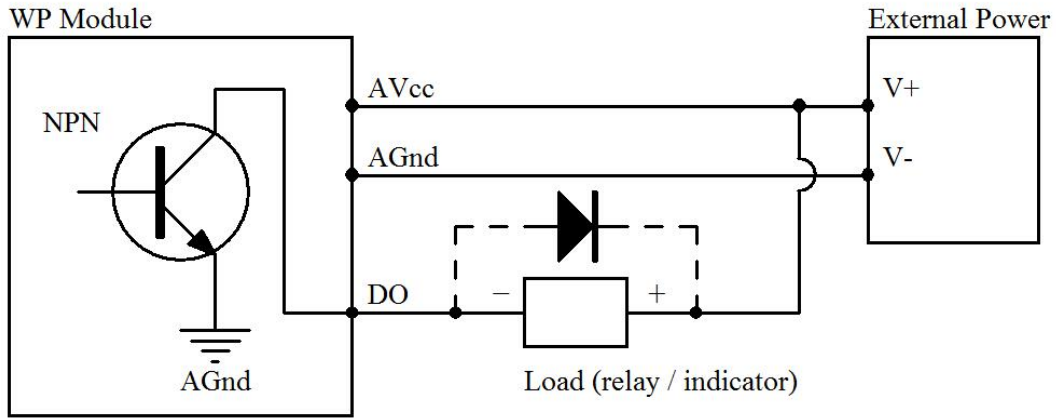

4.3. Analog input application diagram

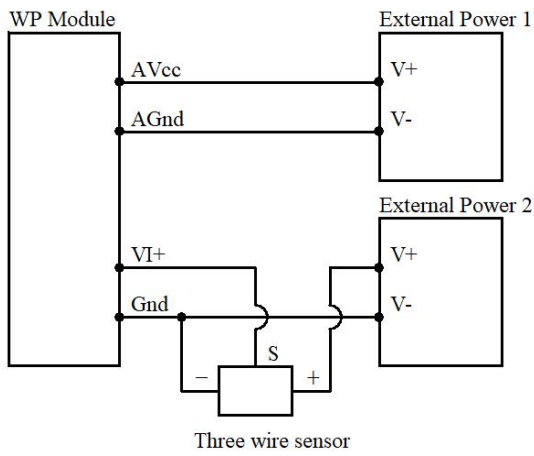

5. Communication description

5.1. Communication parameter: 9600, None, 8, 1 (default setting)

Parameter	Description
9600	baud rate
None	check bit
8	data bit
1	stop bit

5.2、Command for analog input data reading

Send: 01 03 00 00 00 06 C5 C8 (example/hex)

data	byte	data description	remark
01	1	module address	address range:01-FE
03	1	function code	03-read holding register
0000	2	register address (4X type)	0000-starting register address
0006	2	register number	0006-read 6 registers
C5C8	2	CRC check code	CRC check code for all data

Receive: 01 03 0C 05 AF 00 00 00 00 00 00 00 00 00 00 AD 6A (example/hex)

data	byte	data description	remark
01	1	module address	address range:01-FE
03	1	function code	03-read holding register
0C	1	byte of data	0C-read 12 bytes
05AF	12	read data	05AF-analog input channel 1 data
0000			0000-analog input channel 2 data
0000			0000-analog input channel 3 data
0000			0000-analog input channel 4 data
0000			0000-analog input channel 5 data
0000			0000-analog input channel 6 data
AD6A	2	CRC check code	CRC check code for all data

This command reads module's voltage input data.

The data of the analog input channel 1 is "05AF", it will be 1455 after converting to decimal data. Put it in the formula: $V=DATA*10/4095=1455*10/4095\approx 3.55V$. The voltage of other analog input channel is 0V.

5.3、Command for digital input data reading

Send: 01 02 00 00 00 04 79 C9 (example/hex)

data	byte	data description	remark
01	1	module address	address range:01-FE
02	1	function code	02-read digital input register
0000	2	register address (1X type)	0000-starting register address
0004	2	register number	0004-read 4 registers
79C9	2	CRC check code	CRC check code for all data

Receive: 01 02 01 05 61 8B (example/hex)

data	byte	data description	remark
01	1	module address	address range:01-FE
02	1	function code	02-read digital input register
01	1	byte of data	01-read 1 byte
05	1	read data	05-digital input data
618B	2	CRC check code	CRC check code for all data

This command reads module's digital input data.

The data of the digital input is "05", it will be "00000101" after converting to binary data. The last four bits of data correspond to DI_04~DI_01. It means DI_03 and DI_01 are ON.

5.4、Command for digital output data setting (Control of multiple channels)

Send: 01 0F 00 00 00 04 01 03 7E 97 (example/hex)

data	byte	data description	remark
01	1	module address	address range:01-FE
0F	1	function code	0F-write multiple digital output register
0000	2	register address (0X type)	0000-starting register address
0004	2	register number	0004-write 4 registers
01	1	byte of data	01-write 1 byte
03	1	write data	03-digital output data
7E97	2	CRC check code	CRC check code for all data

Receive: 01 0F 00 00 00 04 54 08 (example/hex)

This command sets module to output multiple channels.

The data of the digital output is "03", it will be "00000011" after converting to binary data. The last four bits of data correspond to DO_04~DO_01. It means DO_02 and DO_01 are ON.

When module receives correct command, it will send response back to the master.

5.5. Command for digital output data setting (Control of single channel)

Send: 01 05 00 00 FF 00 8C 3A (example/hex)

data	byte	data description	remark
01	1	module address	address range:01-FE
05	1	function code	05-write single digital output register
0000	2	register address (0X type)	0000-digital output channel 1 register 0001-digital output channel 2 register 0002-digital output channel 3 register 0003-digital output channel 4 register
FF00	2	write data	FF00-ON, 0000-OFF
8C3A	2	CRC check code	CRC check code for all data

Receive: 01 05 00 00 FF 00 8C 3A (example/hex)

This command sets module to output single channel.
When module receives correct command, it will send response back to the master.

5.6. Command for digital output data reading

Send: 01 01 00 00 00 04 3D C9 (example/hex)

data	byte	data description	remark
01	1	module address	address range:01-FE
01	1	function code	01-read digital output register
0000	2	register address (0X type)	0000-starting register address
0004	2	register number	0004-read 4 registers
3DC9	2	CRC check code	CRC check code for all data

Receive: 01 01 01 03 11 89 (example/hex)

data	byte	data description	remark
01	1	module address	address range:01-FE
01	1	function code	01-read digital output register
01	1	byte of data	01-read 1 byte
03	1	read data	03-digital output data
1189	2	CRC check code	CRC check code for all data

This command reads module's digital output data.
The data of the digital output is "03", it will be "00000011" after converting to binary data. The last four bits of data correspond to DO_04~DO_01. It means DO_02 and DO_01 are ON.

5.7. Command for module address setting

Send: 00 06 00 64 00 01 08 04 (example/hex)

date	byte	data description	remark
00	1	module address	00-broadcast address
06	1	function code	06-write single holding register
0064	2	register address (4X type)	0064-module address register
0001	2	write data	0001- module address, range:0001-00FE
0804	2	CRC check code	CRC check code for all data

Receive: 00 06 00 64 00 01 08 04 (example/hex)

This command sets module address (slave address) as "01" (default setting). This setting could be saved when power off. This is a broadcast command. It needs to ensure that only one module is connected to the master.
When module receives correct command, it will send response back to the master.

5.8. Command for communication parameter setting

Send: 01 06 00 65 00 02 18 14 (example/hex)

data	byte	data description	remark
01	1	module address	address range:01-FE
06	1	function code	06-write single holding register
0065	2	register address (4X type)	0065-communication parameter register
0002	2	write data	0001- 4800, None, 8, 1 0002- 9600, None, 8, 1 0003- 19200, None, 8, 1 0004- 38400, None, 8, 1 0005- 4800, Even, 8, 1 0006- 9600, Even, 8, 1 0007- 19200, Even, 8, 1 0008- 38400, Even, 8, 1
1814	2	CRC check code	CRC check code for all data

Receive: 01 06 00 65 00 02 18 14 (example/hex)

This command sets communication parameter as “9600, None, 8, 1” (default setting). This setting could be saved when power off.

When module receives correct command, it will send response back to the master.

6. POWER/DATA LED description

- When module powered on, LED is green.
- When module is under communication, LED is twinkling.
- When module receives correct command, LED is green.
- When module receives incorrect command or other module’s command, LED is red.

7. PC debugging description

We provide a debugging software for function testing and parameter setting. Please follow the steps below:

- Connect computer to module with RS485 converter.
- Connect DC12V or DC24V power to module and power on. To avoid any unnecessary damage, please make sure the power positive and negative terminals are correctly connected before power on.
- Open the software and select the model of module, you will see the window of function testing or parameter setting.
- Set communication parameter and open the serial port.
- Select corresponding setting and click “Read” or “Write” button.

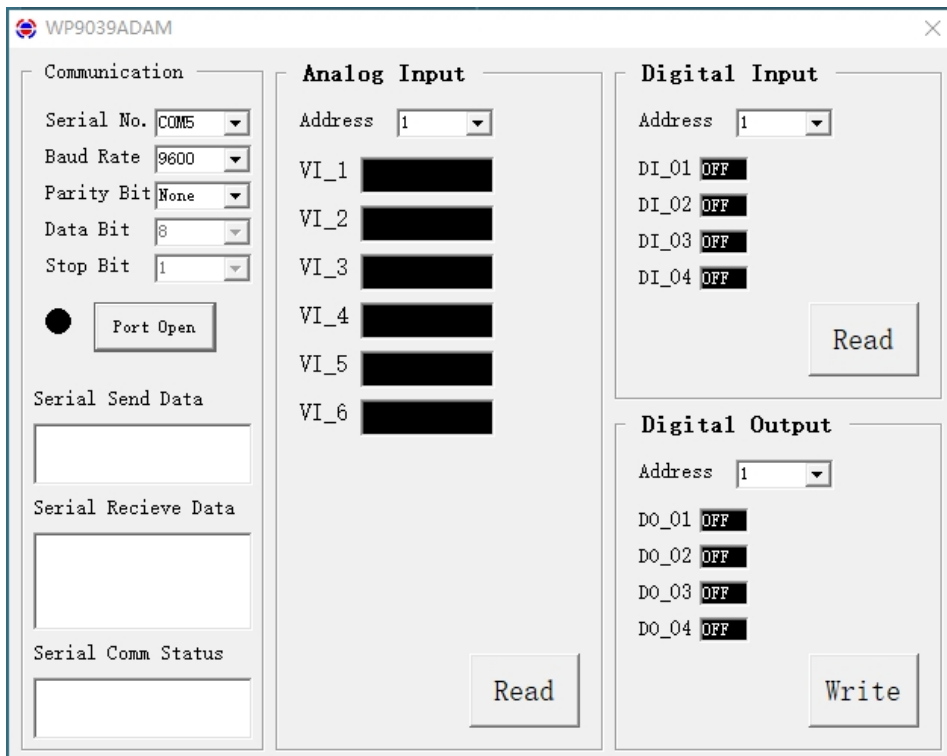

8、RS485 network diagram

