



SENTRY Long Range One Channel Transmitter is a high power code hopping transmitter that is suitable for industrial and domestic applications, where an exceptionally long range is required.

The typical uses include long range operation in large estates, or in areas where normal wireless products perform poorly due to clutter and/or interfering objects/structures. This product is also compatible with all SENTRY code hopping receivers.



TECHNICAL SPECIFICATIONS

Transmission Frequency:

METX-T2 433.92MHz

METX-T2S 403.55MHz

Modulation Format: ASK

Protocol: Code Hopping

Input Voltage: 12V - 24V DC

Average Current Consumption: ~10mA
(100mA when transmitting)

Dimensions: Case: 160x60x45mm

Maximum Distance: 1000m (line of sight)

In conjunction with the Sentry Long Range Receiver. (MERX-T2/MERX-T2S)



ELECTRICAL CONNECTIVITY

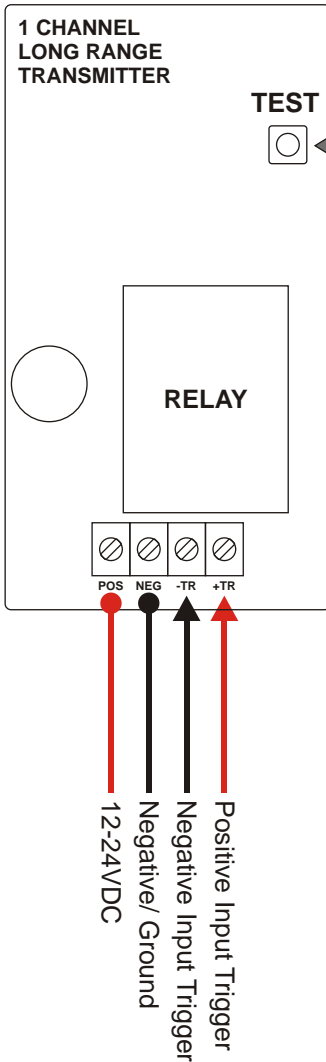

Activating the transmitter:
The unit consists of a TEST button as well as a Single input trigger, which is either positive OR negative trigger.

When either of these inputs are triggered, the unit will transmit a Secure Keeloq code for a duration of ~2 Sec.

Typical Connections:

POS: Positive Input Supply
NEG: Ground
-TR: Negative Input Trigger
+TR: Positive Input Trigger

This transmitter can be programmed to an Sentry receiver or Sentry products with built in receivers as long as you use the correct frequencies.

You can program this transmitter to a receiver by pressing the 'TEST' button or by triggering one of the inputs.

FOLLOW US ON...

 FACEBOOK @Sentrymartinelectronics

 YOUTUBE @sentrymartinelectronics

 INSTAGRAM Sentrymartinelectronics

THIS PRODUCT IS SOLD SUBJECT TO OUR STANDARD TERMS AND CONDITIONS, WHICH MAY BE OBTAINED ON REQUEST FROM MARTIN ELECTRONICS (011) 433 4084 or www.martin-electronics.co.za

