

TOP VIEW

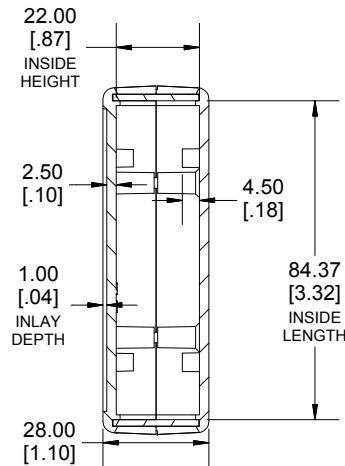

SECTION B-B
SIDE VIEW

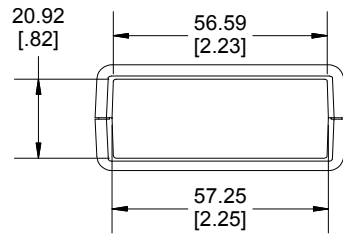
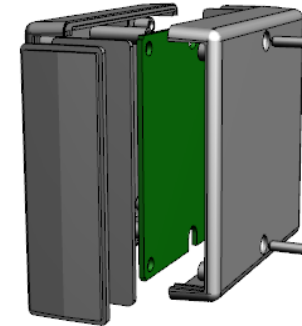

END VIEW

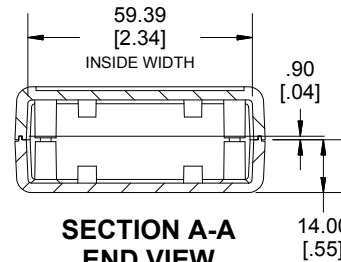

SECTION A-A
END VIEW

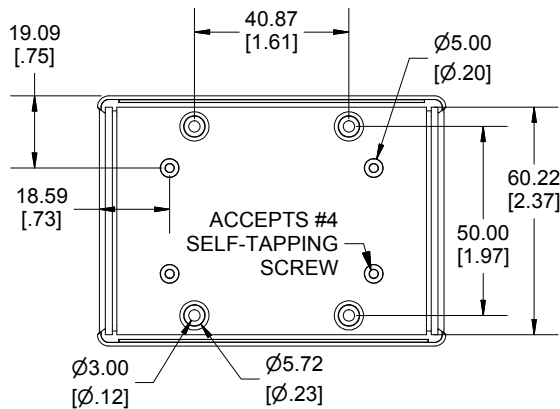

INSIDE BOTTOM

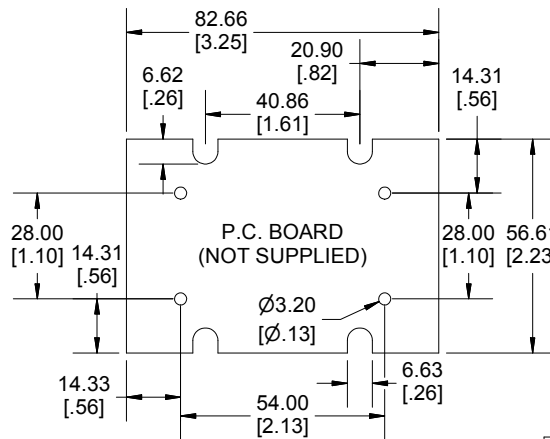

Enclosures can be Factory Modified (Milling, Drilling, Printing etc.)
Contact Factory (modshop@hammondmfg.com) for quotes
Solid models of this enclosure available in STEP or PARA.
(Part number and text placement/orientation on our products are subject to change,
we do not recommend using them as a locating reference for modification purposes)

NOTE		
Enclosure molded from GP ABS (UL94-HB) plastic. Purchased assembly includes top and bottom cover, 4 plastic panels for front and rear (2 types - flat and contoured) and 4 cover screws.		
Recommended Cover Screw Torque - 57lbf-in (40cN-m)		
1593		
1593J Regular Enclosure		
Black Enclosure	1593LBK	
Grey Enclosure	1593LGY	
Translucent Blue Enclosure	1593LTBU	
ACCESSORIES		
Cover Screws #4 X 3/4" Self-Tapping (100 Pkg)	1593QS100 (Silver) 1593QS100BK (Black)	
P.C. Board Screws #4 X 1/4" Self-Tapping	1593ATS50 (Pkg 50) 1593ATS100 (Pkg 100)	
Nylon Belt Clip	1599CLIP (Black) 1599CLIPGY (Grey)	
1593L STD FLAT PANEL (SINGLE PANEL)	Black	1593PLBK-BULK
	Grey	1593PLGY-BULK
	Translucent Blue	1593PLTBU-BULK
	Infrared	1593PIR10
1593L STD CONTOURED PANEL (SINGLE PANEL)	Aluminum	1593PAL10
	Black	1593KCLBK-BULK
	Grey	1593KCLGY-BULK
	Translucent Blue	1593KCLTBU-BULK

Dimensions:
mm
[inches]

