

μA710 High Speed Differential Comparator

Linear Division Comparators

Description

The μA710 is a high speed differential voltage comparator intended for applications requiring high accuracy and fast response times. It is constructed on a single silicon chip using the Fairchild Planar Epitaxial process. The device is useful as a variable threshold Schmitt trigger, a pulse-height discriminator, a voltage comparator in high-speed A/D converters, a memory sense amplifier or a high noise immunity line receiver. The output of the comparator is compatible with all integrated logic forms.

- 5.0 mV Maximum Offset Voltage
- 5.0 μA Maximum Offset Current
- 1000 Minimum Voltage Gain
- 20 μV/°C Maximum Offset Voltage Drift

Absolute Maximum Ratings

Storage Temperature Range	
Metal Can and Ceramic DIP	-65°C to +175°C
Molded DIP	-65°C to +150°C
Operating Temperature Range	
Extended (μA710M)	-55°C to +125°C
Commercial (μA710C)	0°C to 70°C
Lead Temperature	
Metal Can and Ceramic DIP (soldering, 60 s)	300°C
Molded DIP (soldering, 10 s)	265°C
Internal Power Dissipation ^{1, 2}	
8L-Metal Can	1.00 W
14L-Ceramic DIP	1.36 W
14L-Molded DIP	1.04 W
Positive Supply Voltage	+14.0 V
Negative Supply Voltage	-7.0 V
Peak Output Current	10 mA
Differential Input Voltage	±5.0 V
Input Voltage	±7.0 V

Notes

1. $T_{J \text{ Max}} = 150^\circ\text{C}$ for the Molded DIP, and 175°C for the Metal Can and Ceramic DIP.
2. Ratings apply to ambient temperature at 25°C . Above this temperature, derate the 8L-Metal Can at $6.7 \text{ mW}/^\circ\text{C}$, the 14L-Ceramic DIP at $9.1 \text{ mW}/^\circ\text{C}$, and the 14L-Molded DIP at $8.3 \text{ mW}/^\circ\text{C}$.

Connection Diagram 8-Lead Metal Package (Top View)

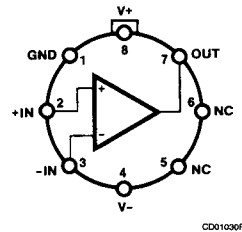

CD01030F

Lead 4 connected to case

Order Information

Device Code	Package Code	Package Description
μA710HM	5W	Metal
μA710HC	5W	Metal

Connection Diagram 14-Lead DIP (Top View)

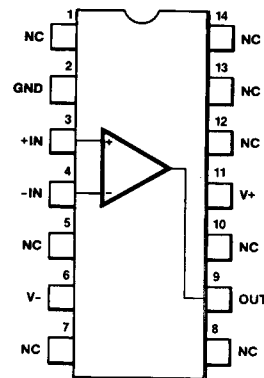

CD01040F

Order Information

Device Code	Package Code	Package Description
μA710DM	6A	Ceramic DIP
μA710DC	6A	Ceramic DIP
μA710PC	9A	Molded DIP

Equivalent Circuit

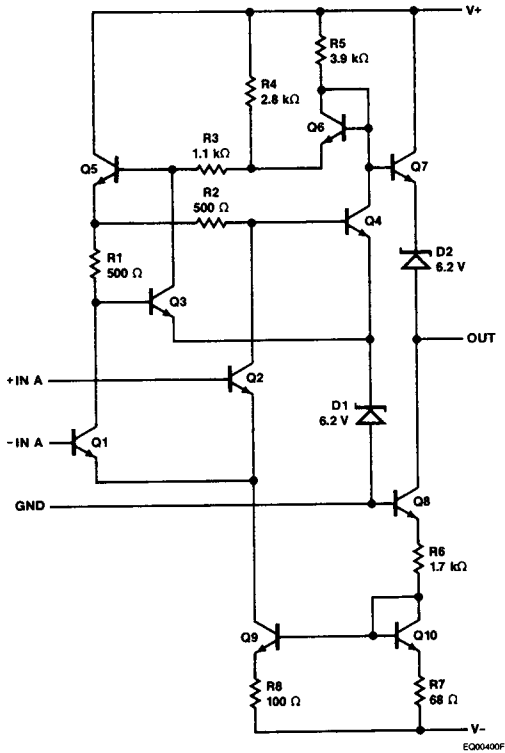

μA710

μA710

Electrical Characteristics $T_A = 25^\circ\text{C}$, $V_+ = 12\text{ V}$, $V_- = -6.0\text{ V}$, unless otherwise specified.

Symbol	Characteristic	Condition ¹	Min	Typ	Max	Unit
V_{IO}	Input Offset Voltage	$R_S \leq 200\ \Omega$		0.6	2.0	mV
I_{IO}	Input Offset Current			0.75	3.0	μA
I_{IB}	Input Bias Current			13	20	μA
A_{VS}	Large Signal Voltage Gain		1250	1700		V/V
R_O	Output Resistance			200		Ω
I_{OL}	Output Sink Current	$\Delta V_I \geq 5.0\text{ mV}$, $V_O = 0\text{ V}$	2.0	2.5		mA
t_{PD}	Response Time ²			40		ns

The following specifications apply for $-55^\circ\text{C} \leq T_A \leq +125^\circ\text{C}$

V_{IO}	Input Offset Voltage	$R_S \leq 200\ \Omega$			3.0	mV
$\Delta V_{IO}/\Delta T$	Average Temperature Coefficient of Input Offset Voltage	$R_S = 50\ \Omega$, $T_A = 25^\circ\text{C}$ to 125°C		3.5	10	μV/°C
		$R_S = 50\ \Omega$, $T_A = +25^\circ\text{C}$ to -55°C		2.7	10	
I_{IO}	Input Offset Current	$T_A = +125^\circ\text{C}$		0.25	3.0	μA
		$T_A = -55^\circ\text{C}$		1.8	7.0	
$\Delta I_{IO}/\Delta T$	Average Temperature Coefficient of Input Offset Current	$T_A = 25^\circ\text{C}$ to 125°C		5.0	25	nA/°C
		$T_A = +25^\circ\text{C}$ to -55°C		15	75	
I_{IB}	Input Bias Current	$T_A = -55^\circ\text{C}$		27	45	μA
V_{IR}	Input Voltage Range	$V_- = -7.0\text{ V}$	± 5.0			V
CMR	Common Mode Rejection	$R_S \leq 200\ \Omega$	80	100		dB
V_{IDR}	Differential Input Voltage Range		± 5.0			V
A_{VS}	Large Signal Voltage Gain		1000			V/V
V_{OH}	Output Voltage HIGH	$\Delta V_I \geq 5.0\text{ mV}$, $0\text{ mA} \leq I_{OH} \leq 5.0\text{ mA}$	2.5	3.2	4.0	V
V_{OL}	Output Voltage LOW	$\Delta V_I \geq 5.0\text{ mV}$	-1.0	-0.5	0	V
I_{OL}	Output Sink Current	$T_A = +125^\circ\text{C}$, $\Delta V_I \geq 5.0\text{ mV}$, $V_O = \text{GND}$	0.5	1.7		mA
		$T_A = -55^\circ\text{C}$, $\Delta V_I \geq 5.0\text{ mV}$, $V_O = \text{GND}$	1.0	2.3		
I_+	Positive Supply Current	$V_O = \text{GND}$		5.2	9.0	mA
I_-	Negative Supply Current	$V_O = \text{GND}$, Inverting Input = 5.0 mV		4.6	7.0	mA
P_C	Power Consumption	$V_O = \text{GND}$, Inverting Input = 10 mV		90	150	mW

μA710

μA710C

Electrical Characteristics $T_A = 25^\circ\text{C}$, $V_+ = 12\text{ V}$, $V_- = -6.0\text{ V}$, unless otherwise specified.

Symbol	Characteristic	Condition ¹	Min	Typ	Max	Unit
V_{IO}	Input Offset Voltage	$R_S \leq 200\ \Omega$		1.6	5.0	mV
I_{IO}	Input Offset Current			1.8	5.0	μA
I_{IB}	Input Bias Current			16	25	μA
A_{VS}	Large Signal Voltage Gain		1000	1500		V/V
R_O	Output Resistance			200		Ω
I_{OL}	Output Sink Current	$\Delta V_I \geq 5.0\text{ mV}$, $V_O = 0\text{ V}$	1.6	2.5		mA
t_{PD}	Response Time ²			40		ns

The following specifications apply for $0^\circ\text{C} \leq T_A \leq 70^\circ\text{C}$

V_{IO}	Input Offset Voltage	$R_S \leq 200\ \Omega$			6.5	mV
$\Delta V_{IO}/\Delta T$	Average Temperature Coefficient of Input Offset Voltage	$R_S = 50\ \Omega$, $T_A = 0^\circ\text{C}$ to 70°C		5.0	20	μV/°C
I_{IO}	Input Offset Current				7.5	μA
$\Delta I_{IO}/\Delta T$	Average Temperature Coefficient of Input Offset Current	$T_A = 25^\circ\text{C}$ to 70°C		15	50	nA/°C
		$T_A = 25^\circ\text{C}$ to 0°C		24	100	
I_{IB}	Input Bias Current	$T_A = 0^\circ\text{C}$		25	40	μA
V_{IR}	Input Voltage Range	$V_- = -7.0\text{ V}$	± 5.0			V
CMR	Common Mode Rejection	$R_S \leq 200\ \Omega$	70	98		dB
V_{IDR}	Differential Input Voltage Range		± 5.0			V
A_{VS}	Large Signal Voltage Gain		800			V/V
V_{OH}	Output Voltage HIGH	$\Delta V_I \geq 5.0\text{ mV}$, $0\text{ mA} \leq I_{OH} \leq 5.0\text{ mA}$	2.5	3.2	4.0	V
V_{OL}	Output Voltage LOW	$\Delta V_I \geq 5.0\text{ mV}$	-1.0	-0.5	0	V
I_{OL}	Output Sink Current	$\Delta V_I \geq 5.0\text{ mV}$, $V_O = \text{GND}$	0.5			mA
I+	Positive Supply Current	$V_O = \text{GND}$		5.2	9.0	mA
I-	Negative Supply Current	$V_O = \text{GND}$, Inverting Input = 5.0 mV		4.6	7.0	mA
P_C	Power Consumption	$V_O = \text{GND}$, Inverting Input = 10 mV		90	150	mW

Notes

- The input offset voltage and input offset current are specified for a logic threshold voltage as follows: For μA710, 1.8 V at -55°C , 1.4 V at $+25^\circ\text{C}$, 1.0 V at $+125^\circ\text{C}$. For μA710C, 1.5 V at 0°C , 1.4 V at 25°C , and 1.2 V at 70°C .
- The response time specified is for a 100 mV input step with 5.0 mV overdrive.

Typical Performance Curves for μA710

Voltage Transfer Characteristic

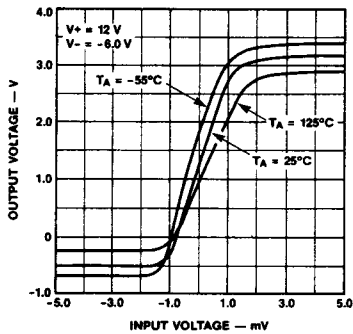

PC06960F

Voltage Gain vs Temperature

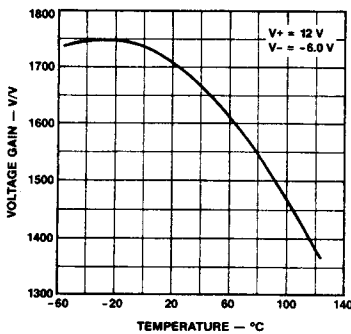

PC06960F

Voltage Gain vs Supply Voltages

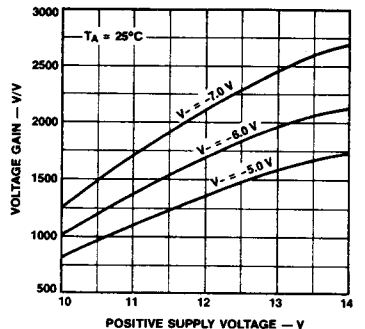

PC07000F

Input Bias Current vs Temperature

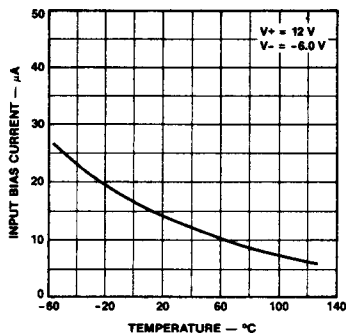

PC07010F

Input Offset Current vs Temperature

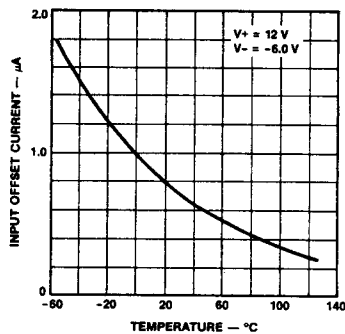

PC07020F

Common Mode Rejection Ratio vs Temperature

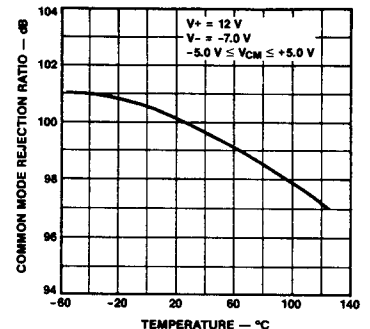

PC07030F

Power Consumption vs Temperature

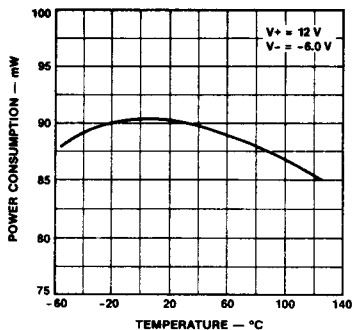

PC07040F

Output Sink Current vs Temperature

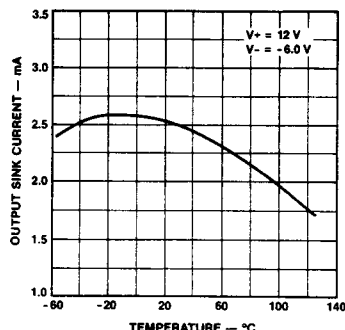

PC07050F

Output Voltage Levels vs Temperature

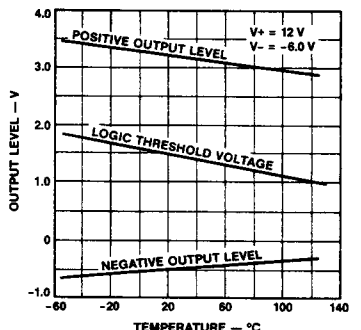

PC07060F

Typical Performance Curves for μA710 (Cont.)

Response Time for Various Input Overdrives

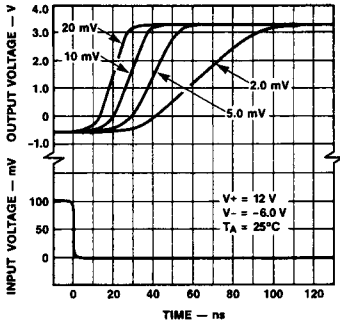

Response Time for Various Input Overdrives

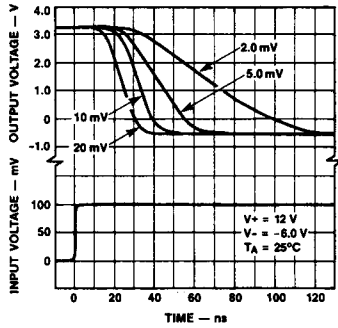

Common Mode Pulse Response

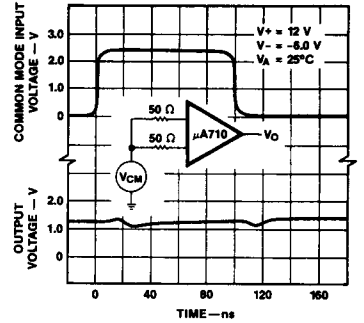

8

Typical Performance Curves for μA710C

Voltage Transfer Characteristic

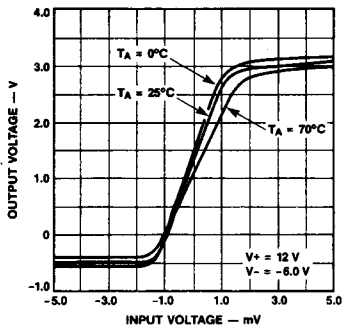

Voltage Gain vs Ambient Temperature

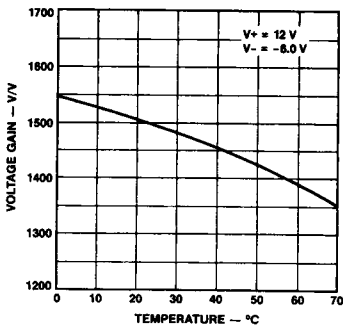

Voltage Gain vs Supply Voltages

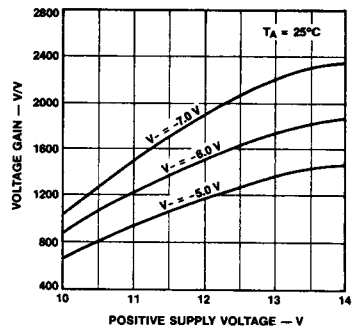

Input Bias Current vs Temperature

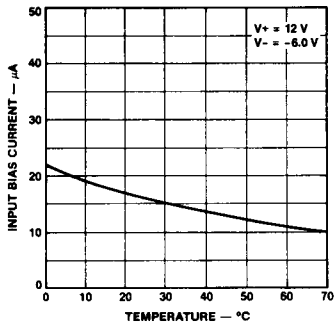

Input Offset Current vs Temperature

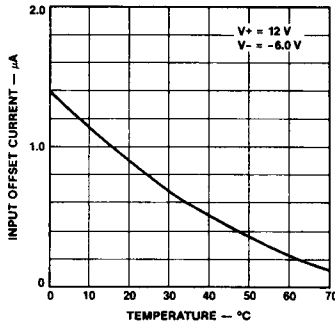

Common Mode Rejection Ratio vs Temperature

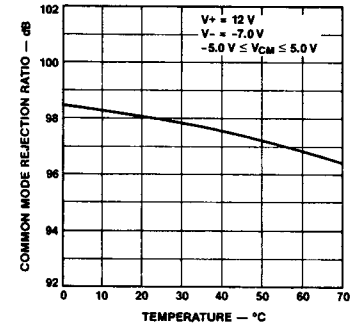

Typical Performance Curves for μ A710C (Cont.)

Power Consumption vs Temperature

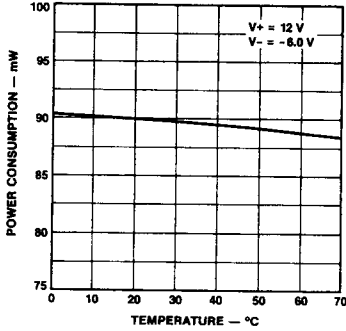

PC07170F

Output Sink Current vs Temperature

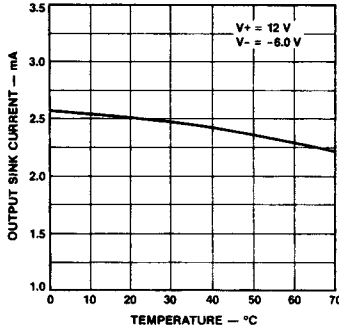

PC07180F

Output Voltage Levels vs Temperature

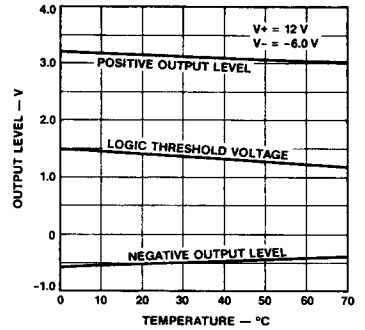

PC07190F

Response Time for Various Input Overdrives

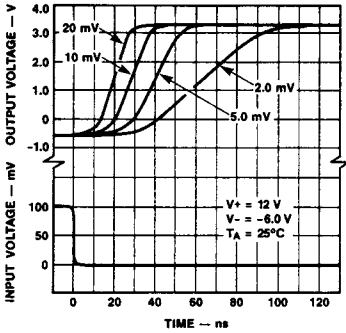

PC07070F

Response Time for Various Input Overdrives

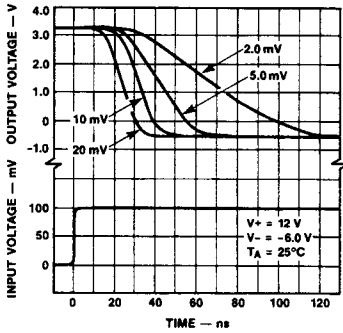

PC07081F

Common Mode Pulse Response

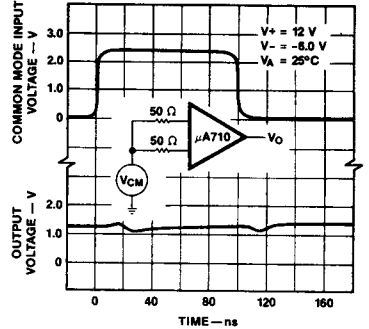

PC07090F