

Parallel Installation Guide For Sonar ECO-Hybrid Inverter

2021-7-9

PART1: Single Phase Parallel System Wiring

Lux power ECO Hybrid inverter support “Parallel Connection”, which means you can combine multiple inverters together to get bigger back-up power.

Step1. Single unit installation

Install each single phase inverter as user manual. Before installation, please make sure the distance between each inverter meet the requirements of user manual.

Step2. Parallel system wiring

If you paralleling the system as single phase system, the most important thing is to make sure the L & N lines of each unit (AC port And EPS port) are correctly connected, please check with multi-meter to make sure L cable of each units are connected. Do not connect one inverter’s L cable to another inverter’s N cable.

The single phase inverters in parallel diagram:

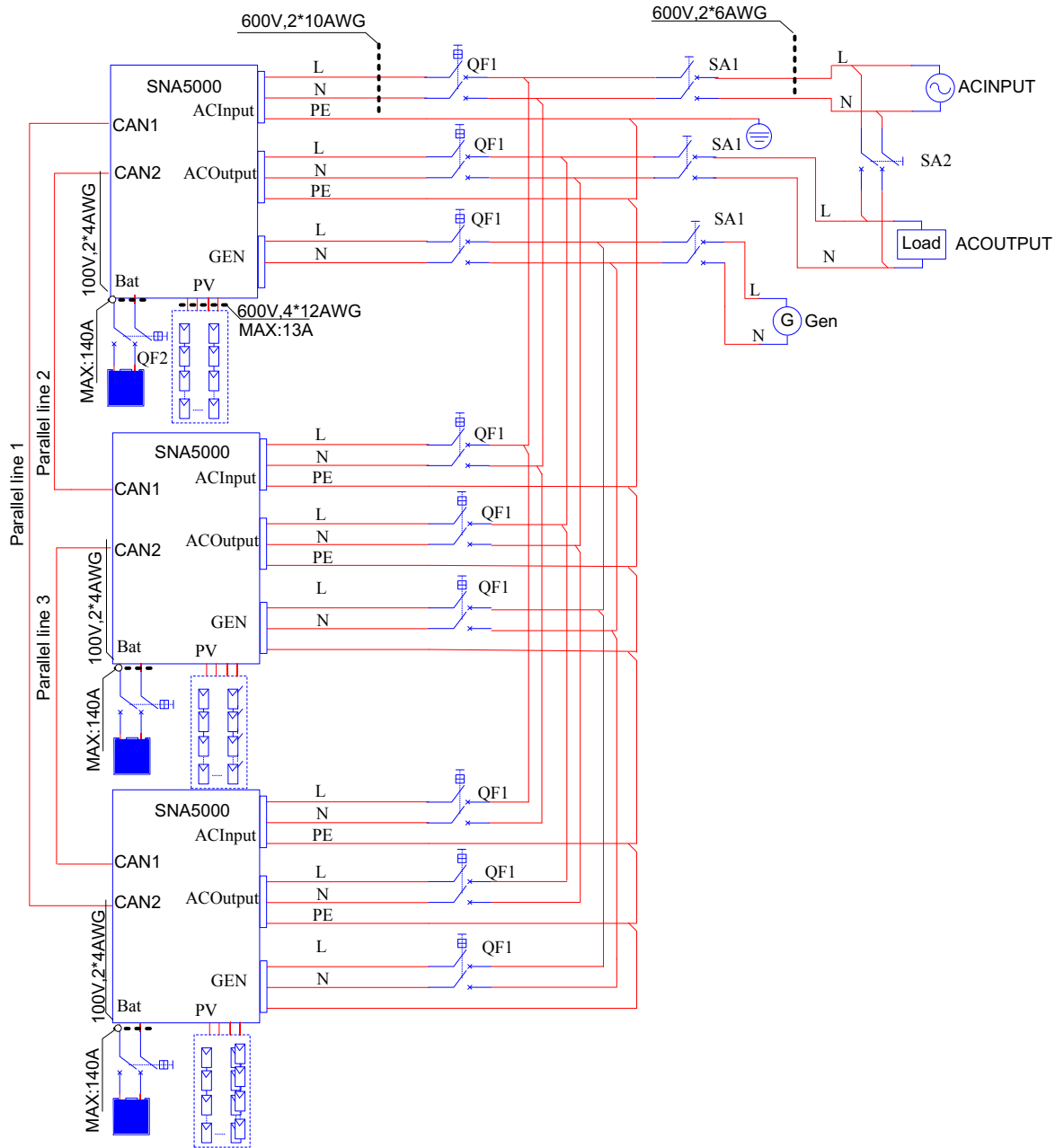

Not share the battery

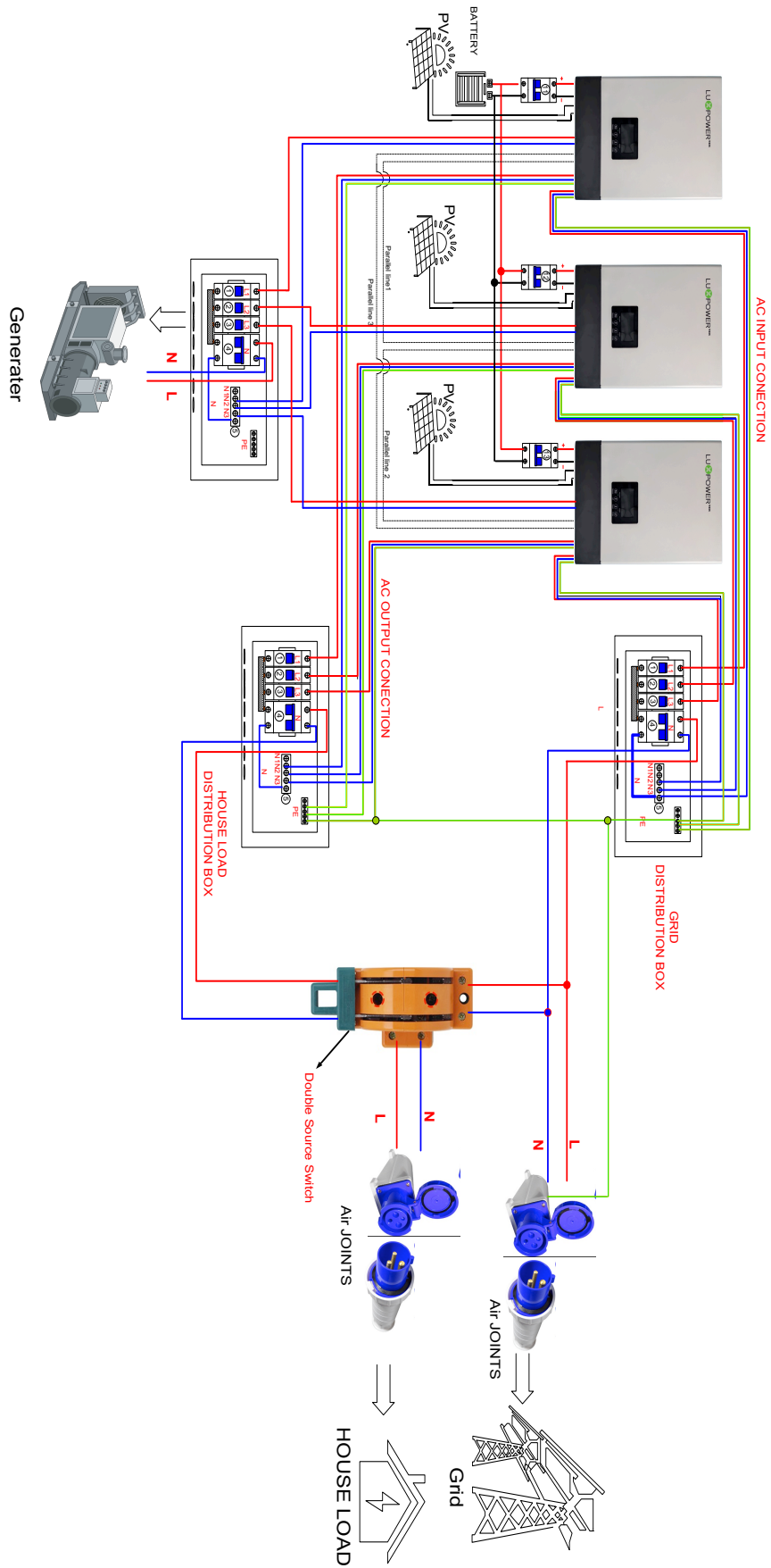

✓ **Recommend Capacity Section of battery:**

Inverter parallel numbers	2	3	4	5	6
Battery Capacity	400 AH	600 AH	800A H	1000 AH	1200 AH

***At least 200AH per unit**

✓ **Cross Section of connection cable:**

Position	Cross Section (Length \leq 20m)	Note
AC Input to QF1	$\geq 5.26 \text{ mm}^2$	Maximum Grid current is 40A
AC Output to QF1	$\geq 5.26 \text{ mm}^2$	Nominal current is 25A
GEN Port to QF1	$\geq 5.26 \text{ mm}^2$	Maximum current is 25A
QF1 Port to SA1	$\geq 5.26 \text{ mm}^2$	Maximum current is 25A
SA1 to AC	$\geq 6 \text{ mm}^2 * 3$	Maximum current is 40A*n
SA1 to AC	$\geq 5.26 \text{ mm}^2 * 3$	Maximum current is 25A*n
SA1 to AC	$\geq 5.26 \text{ mm}^2 * 3$	Maximum current is 25A*n

****1) Copper wire 1 mm^2 safe current carrying capacity is 5 amps (within 20 meters distance)**

2) The PE line can be chosen between 6~10 mm^2

3) N means the number of parallel

Step3. Set up the parallel CAN communication balance resistance.

- Connect parallel communication cable. The port4 are used for parallel connection.
- Switch ③ are used for the parallel communication balance resistance.

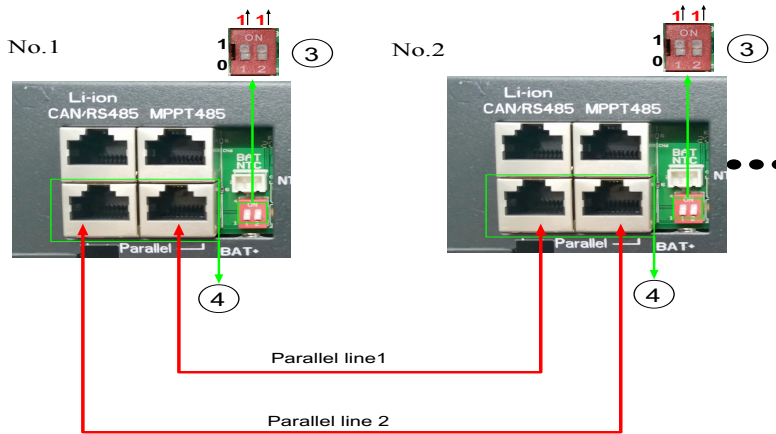

- If there are more than two inverters parallel in your system, only two of longest distance of need to be dialed toward “on ”position: 1 1 1 , and others keep off: 0 0 0

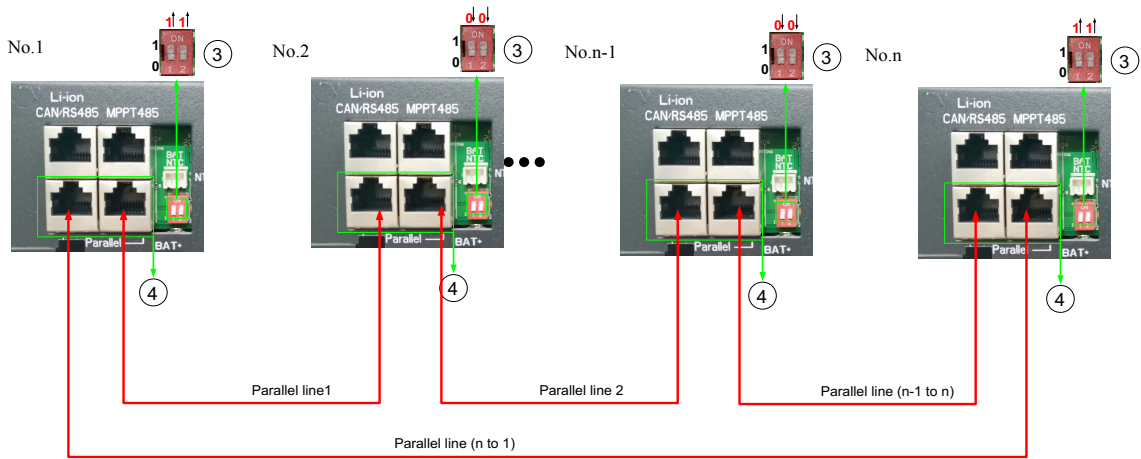

The maximum parallel quantity is 16PCS

- For other ports' definition, please refer to user manual.
- Please double check if the wirings are correct.
- The parallel port are pin-to-pin with each other for PIN1~PIN8, and you can buy this easily in any computer shop



➤ Step4. Set up the monitor system and do settings

- Power on the inverter and connect Wi-Fi to dongle to internet.
- For parallel system battery connection, we support 2 ways to connect, you can either connect all inverters to one battery bank or connect each inverter to separate battery group. Or it is connected as each inverter connect to separate battery.
- If you connect one battery bank shared by multiple inverters as the diagram above,

please enable "Battery shared" and set the system to Single phase Parallel

Parallel Settings

Set System Type (?) No Parallel Set

Set Composed Phase (?) No Parallel Set

Single Phase Parallel

Three Phase Parallel

Battery Shared Enable Disable

➤ Step5. Running the system

- Check all connection and make sure is correct.
- Power on all Units and Check the all AC output is OK
- Turn on all breakers

PART2: Three Phase System Wiring

Step1. Install each single inverter as user manual

Lux power inverter support three phase system, which means 3 pcs or more inverters can be used to compose a three phase system. This part will show you how to set up a three phase system.

Step2. Parallel connection

Wiring the parallel system as below suggestions for safety and cost reasons.

When paralleling the system as three phase system, make sure there is at least one inverter in each phase. **DO NOT connect** AC Output terminals all together when used in 3 phase system, otherwise you will short the grid/utility. Three phase system composed by three inverters diagram:

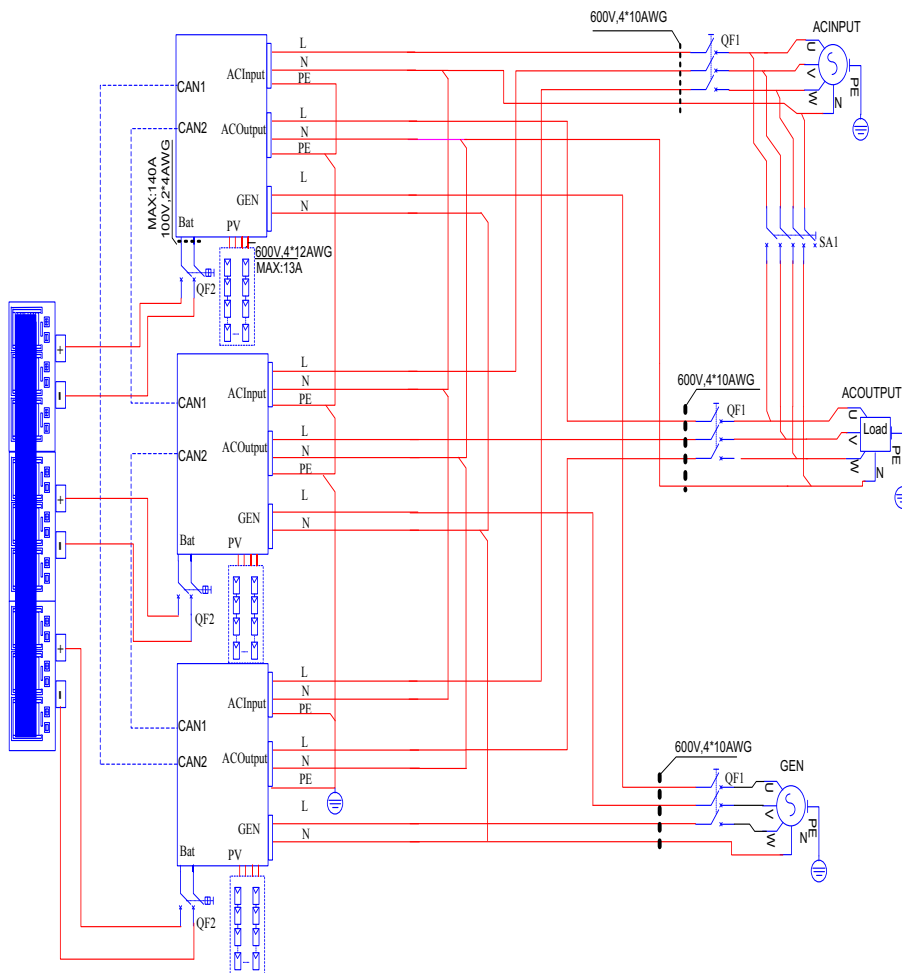

share the battery

✓ **Recommend Capacity Section of battery:**

Inverter parallel numbers	3	4	5	6
Battery Capacity	600A H	800AH	1000A H	1200A H

*At least 200AH per unit

✓ **Cross Section of L1,L2,L3&N lines:**



Position	Cross Section (Length ≤ 20m)	Note
AC Input (L1,L2,L3&N) to QF1	≥ 8mm ²	Maximum Grid current is 40A
AC Output (L1,L2,L3&N) to QF1	≥ 5.26mm ²	Nominal current is 25A
GEN (L1,L2,L3) to QF1	≥ 8mm ²	Maximum current is 25A
BATTERY to QF2	≥ 20mm ²	Maximum current is 25A
AC Input (L1,L2,L3&N) / AC Output (L1,L2,L3&N) to Per SNA5000	≥ 5.26mm ²	Nominal current is 25A

**1) Copper wire 1 mm² safe current carrying capacity is 5 amps (within 20 meters distance) for AC and EPS lines.

2) The PE line can be chosen between 3~4 mm²

➤ **Step3. Set up the parallel CAN communication balance resistance.**

- Connect parallel communication cable. The port4 are used for parallel connection.
- Switch ③ are used for the parallel communication balance resistance,
- If there are only three inverters parallel in this three-phase system, Switch ③ of No.1

and No.3 need to be dialed toward “on” position:  , and No.2 keeps off: 

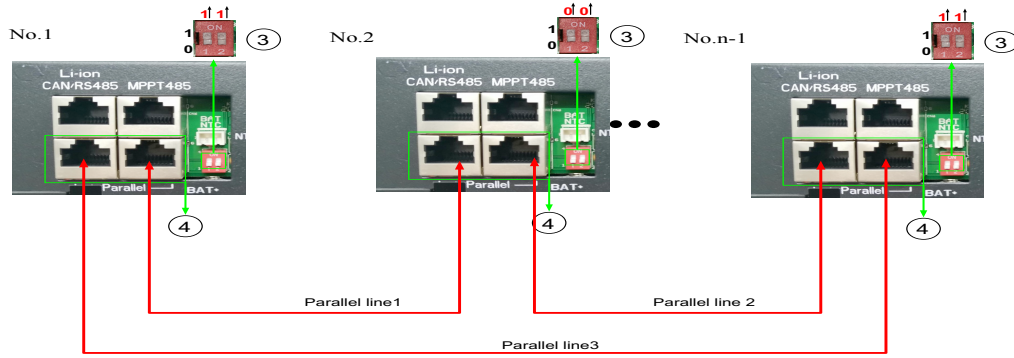

- For other ports' definition, please refer to user manual.
- Please double check if the wirings are correct.
- The parallel port are pin-to-pin with each other for PIN1~PIN8, and you can buy this easily in any computer shop



➤ **Step4. Set up the monitor system and do settings**

- Power on the inverter and connect Wi-Fi to dongle to internet.
- For parallel system battery connection, we support 2 ways to connect, you can either connect all inverters to one battery bank or connect each inverter to separate battery group. Or it is connected as each inverter connect to separate battery.
- If you connect one battery bank shared by multiple inverters as the diagram above, please enable "Battery shared".

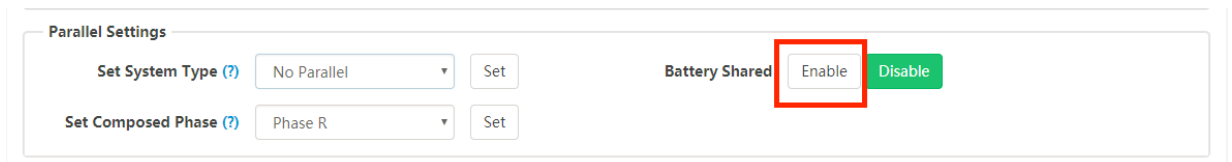

For three phase system, Please set to three phase system and set phase for each inverter

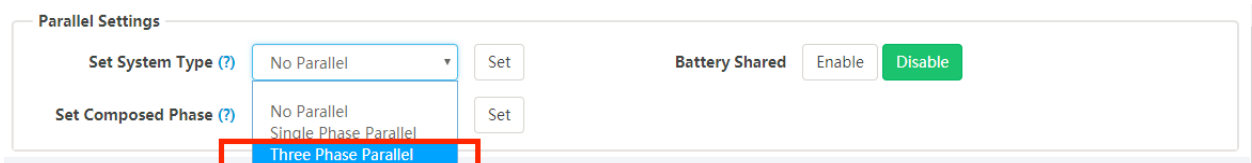

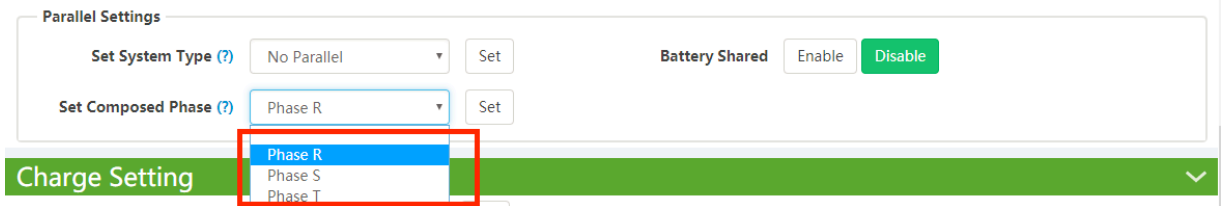

➤ **Step5. Running the system**

- Check all connection and make sure is correct.
- Power on all Units and Check the all AC output is OK
- Turn on all breakers

Related Fault

Fault	Description	
E008	CAN communication error in Parallel System	<ol style="list-style-type: none"> 1. Please check if you have connect parallel communication cable 2. Check the cable connection is connected to the right COM port 3. Check the cable is right 4. Check if you have put the resistor PIN on 5. If you run system as single unit, please set no parallel in the monitor system
E011	AC inconsistent in parallel system	Check if AC Connection is same for all inverters in parallel system
E015	Phase Error in three phase parallel system	Check the phase setting is right, if you set single phase system, then each inverter should be R phase; If you set three phase system, then there should be R phase inverter, S phase inverter and T phase inverter