

**Connectors according  
to UIC 541-5 VE  
EP Series**

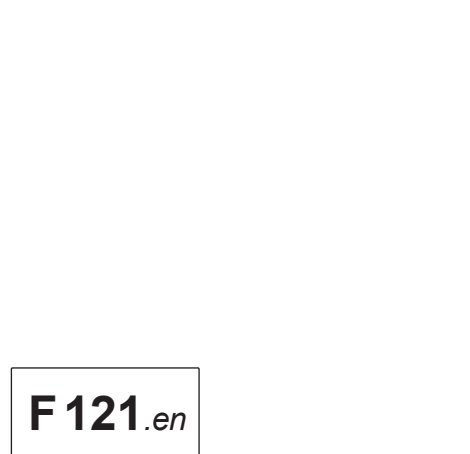
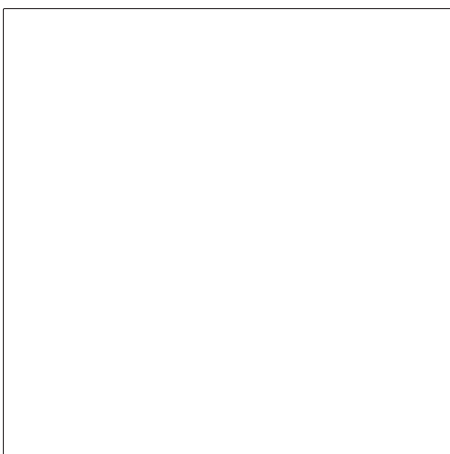
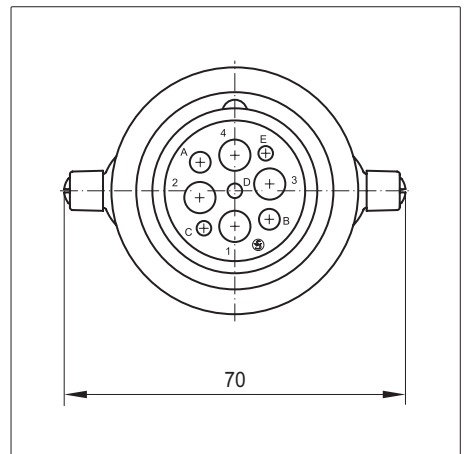
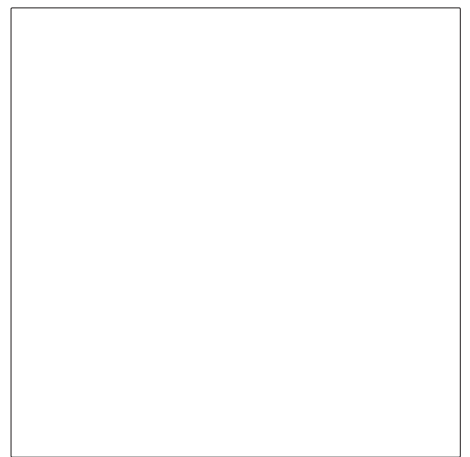

**F 121.en**

## Connector to UIC standard 541-5 VE, EP Series

The connector is designed in accordance with the specifications of the international railway standard UIC 541-5. It adds to the range of our well-proven connectors for the railway industry. This heavy-duty connector is designed to ensure the electrical connection within a train for the electropneumatic brakes (EP brakes) as well as the bypass of an electropneumatic emergency brake.

Both systems have functions which overlap through their control and monitoring elements. They are fed by a common electrical cable that runs the length of the train. Integrated in the receptacle is a switching element as pilot contact which is used for feedback signalling a plug being mated, whereas the end of train is signalled by means of a pin contact in the dummy receptacle.







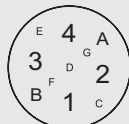

### Features

- **Feedback**
  - Plug being mated: via a switching element integrated in the receptacle shell
  - End of train: via a pin contact in the dummy receptacle
- **Shell:**
  - Receptacle shell with metal handle
  - Metal latch locking: Handle of receptacle and plug when mated
  - New design ensuring better protection against splashwater
- **Contacts:**
  - High-quality, screw machine contacts
  - gold or silver plated
  - Crimp terminals

### Applications

- **DMUs, EMUs, rail cars, and passenger coaches:**  
Power and signal transfer for electropneumatic brakes as well as electropneumatic emergency brake override (EBO)
- **Freight wagons:**  
Power and signal transfer for electropneumatic brakes

### Specifications

Connectors	EP Series		
Applicable standard	UIC 541-5 VE		
Contact arrangement and identification	 		
Rated voltage	250 V		
Contacts	Contact cavities	Wire gauge	Rated current
        ---      ---	1, 2, 3, 4 A, B C, E D F, G	AWG 7 AWG 9 AWG 18 ... 16 AWG 12 empty	35 A 25 A 6 A 12 A ---
Terminal type	Crimp		
Pilot contact	integrated in receptacle shell together with 1 S870 Series SPDT, 10 A (see catalogue D70e)		
Contact resistance (IEC 60512-2)	≤ 2 mΩ		
Operating temperature range	- 30 °C ... + 80 °C		
Degree of protection (IEC 60529)	Mated connector: IP66 / Receptacle with handle closed: IP66		
Test standard (IEC 60068-1), (t <sub>min</sub> [°C] / t <sub>max</sub> [°C] / t <sub>testing time</sub> [days])	15/100/21		
Mechanical endurance (IEC 60512-5, test 9a)	> 10,000 mating cycles		
Materials	Receptacle shell: Aluminium die-cast Plug shell: Polyamide PA 6.6, black Inserts: for plugs: Polyamide PA 6.6, black; for receptacles: Polyamide PA 6, black Seals: Thermoplastic elastomer (TME) / Neoprene Contacts: Copper wrought alloy, crimpable Finish: Silver or gold plated		

**Ordering code** EP Series

● EP plug:

EP SK L3000

Series

EP

Connector type

- ST Plug
- SK Connector cable, single ended
- VK Connector cable, double ended

Cable length (SK and VK only)

- L2000 Cable length 2000 mm
- L3000 Cable length 3000 mm
- L4500 Cable length 4500 mm

● EP receptacle:

EP DK R1 S1 K1 E Lxxxx

Series

EP

Connector type

- KD Receptacle
- BD Dummy receptacle
- DK Connector cable with receptacle

Backshell

- R0 none
- R1 with cable gland M40x1.5
- R2 with adapter Pg29
- R3 without adapter
- R4 made of metal

Pilot contact

- S0 none
- S1 existent

Terminal block

- K0 none
- K1 existent

Drainage slots

- E existent

Cable length (DK only)

- Lxxxx Cable length to customer requirements

**Note**

In this catalogue only stock items are presented that can be delivered immediately.

**Variants**

Do you need a special variant? Do not hesitate to contact us! Maybe the connector you are looking for is among our many **special designs**. If not, we also deliver connectors **manufactured to customer requirements**. In this case, however, minimum order quantities apply.

**EP ST** Plug, socket contacts included EP Series

● Plug

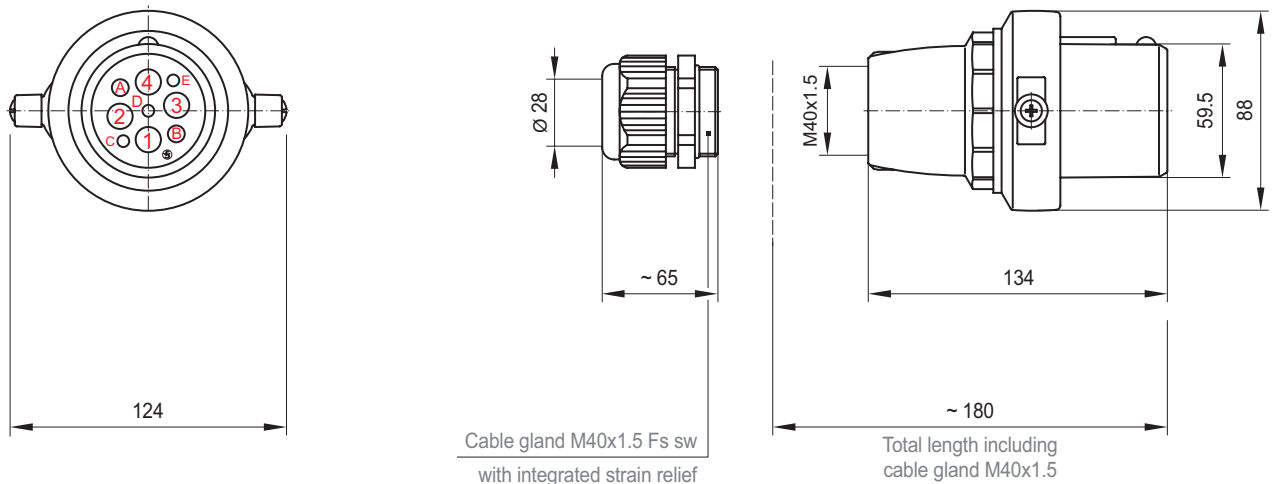

**EP KD R0...4 Sx Kx E** Receptacle, pin contacts included

EP Series

- Receptacle without backshell  
Type R0

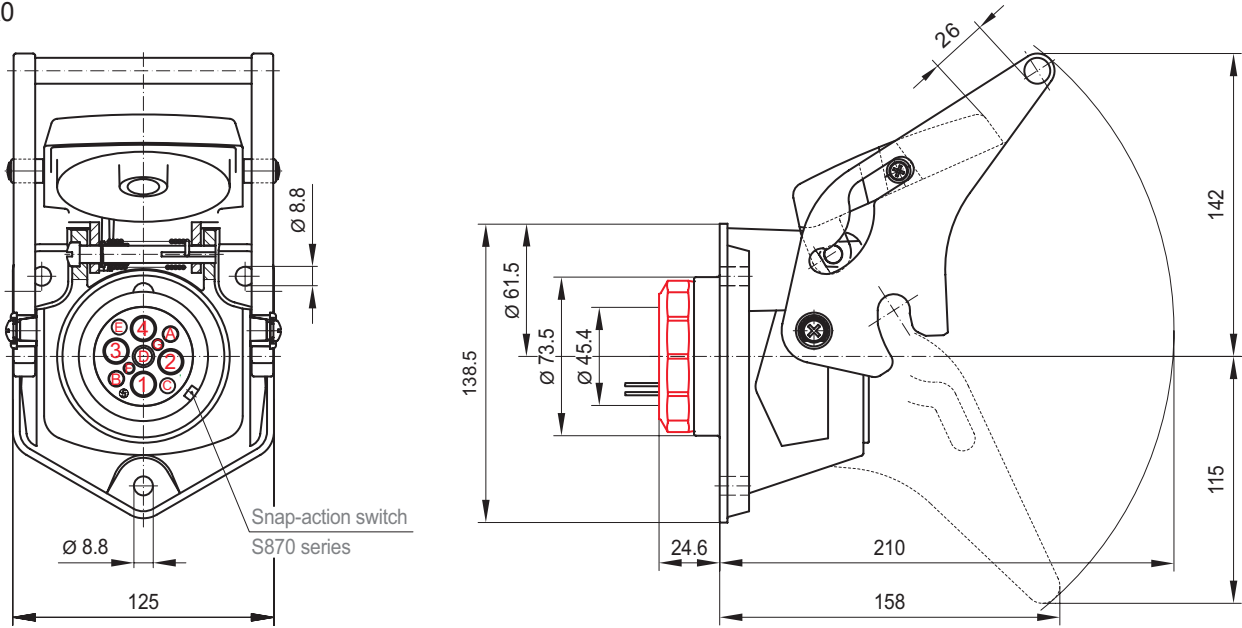

- Receptacle with backshell and cable gland M40x1.5  
Type R1

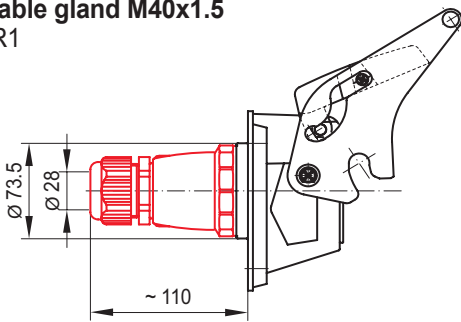

- Receptacle with backshell and adapter Pg29  
Type R2

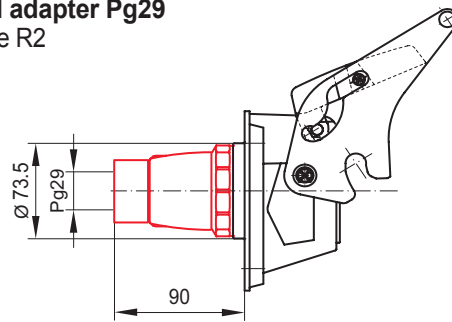

- Receptacle with backshell without adapter  
Type R3

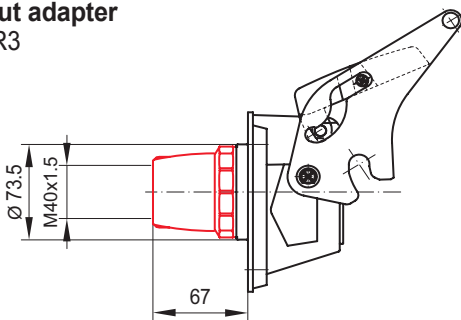

- Receptacle with metal backshell  
Type R4

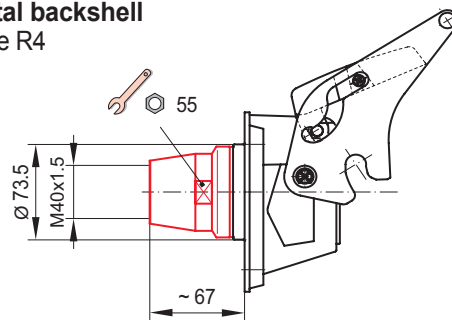

**EP BD R0/R2 Sx Kx E** Dummy receptacle, 1 pin contact for feedback included

EP Series

- Dummy receptacle without backshell  
Type R0

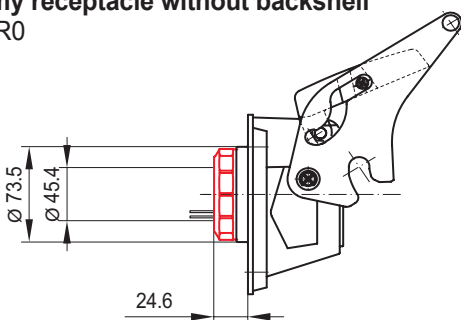

- Dummy receptacle with backshell and adapter Pg29  
Type R2

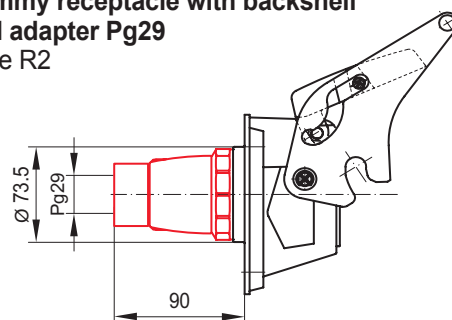

# Contacts Crimp contacts (pin/socket)

EP Series

## ● Ordering code contacts

Contacts

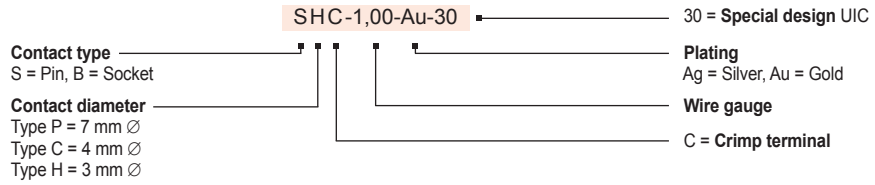

## ● Crimp contacts for cavities 1, 2, 3, 4

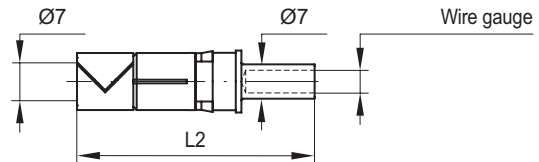
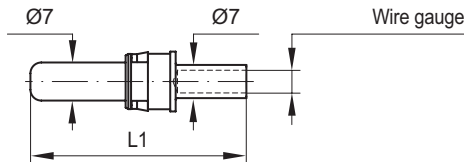

Ordering code	L1	Pin contact
SPC-10,0-Ag	39.7	for receptacle
SPC-2,5-Ag *	39.7	for dummy

Ordering code	L2	Socket contact
BPC-10,0-Ag	42.2	for plug

Wire gauge	Rated current
AWG 7 (10 mm <sup>2</sup> )	35 A
AWG 12 (2.5 mm <sup>2</sup> )	12 A

\* For feedback signalling end of train only one pin contact is implemented in contact cavity 4 of a dummy receptacle

## ● Crimp contacts for cavities A, B

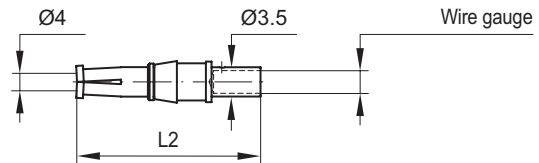
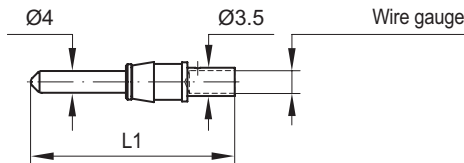

Ordering code	L1	Pin contact
SCC-6,00-Ag	37.5	for receptacle

Ordering code	L2	Socket contact
BCC-6,00-Ag	32.6	for plug

Wire gauge	Rated current
AWG 9 (6 mm <sup>2</sup> )	25 A

## ● Crimp contacts for cavities C, E

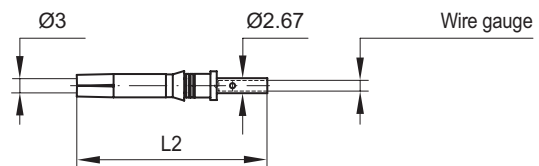
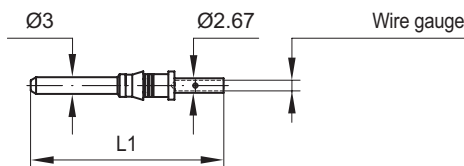

Ordering code	L1	Pin contact
SHC-1,00-Au-30	35.5	for receptacle

Ordering code	L2	Socket contact
BHC-1,00-Au-30	33.8	for plug

Wire gauge	Rated current
AWG 16 (1 mm <sup>2</sup> )	6 A

## ● Crimp contacts for cavity D

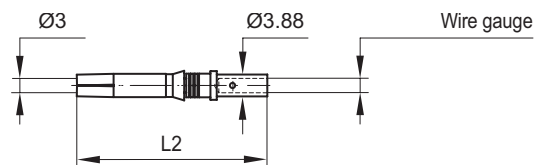
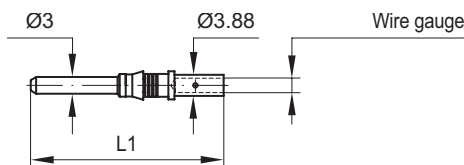

Ordering code	L1	Pin contact
SHC-2,50-Au-30	35.5	for receptacle

Ordering code	L2	Socket contact
BHC-2,50-Au-30	33.8	for plug

Wire gauge	Rated current
AWG 12 (2.5 mm <sup>2</sup> )	6 A

**CWZ-120, CWZ-600** Crimp tools

**AWZ-C/H, AWZ-P** Extraction tools

Tools

● **CWZ-120, CWZ-600** Crimp tools



Ordering code	Description
<b>CWZ-120</b>	Crimp tool for wire gauges AWG 7 ... 250 MCM (10 mm <sup>2</sup> ... 120 mm <sup>2</sup> ), contacts Type P
<b>CWZ-600</b>	Crimp tool for wire gauges AWG 25 ... 9 (0.14 mm <sup>2</sup> ... 6 mm <sup>2</sup> ), contacts Type C and H

● **AWZ-C/H, AWZ-P** Extraction tools



Order code	Description
<b>AWZ-C/H</b>	Extraction tool for contacts, Type C and H
<b>AWZ-P</b>	Extraction tool for contacts, Type P

Fig. similar

**Pre-assembled cables** Connector cables, single or double ended

EP Series

● **EP VK Lxxxx** Connector cable, double ended

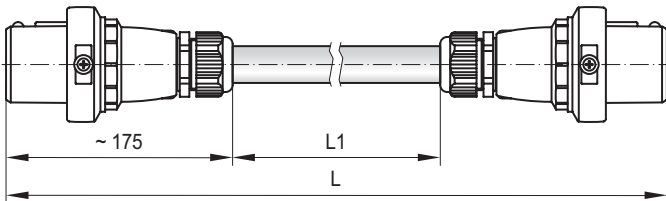

Ordering code	Total length L	Length L1
EP VK <b>L2000</b>	2000 mm ± 10	1650 mm
EP VK <b>L3000</b>	3000 mm ± 10	2650 mm
EP VK <b>L4500</b>	4500 mm ± 10	4150 mm

● **EP SK Lxxxx** Connector cable, single ended

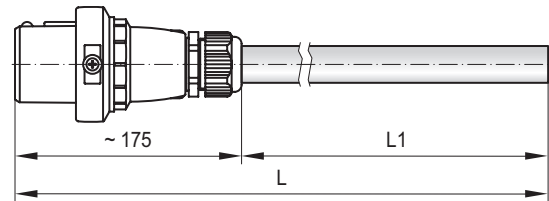

Ordering code	Total length L	Length L1
EP SK <b>L2000</b>	2000 mm ± 10	1825 mm
EP SK <b>L3000</b>	3000 mm ± 10	2825 mm
EP SK <b>L4500</b>	4500 mm ± 10	4325 mm

● **EP DK Ra Sb Kc Lxxxx** Receptacle with connector cable

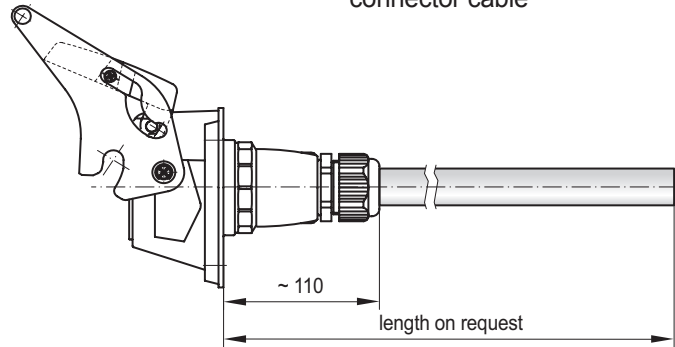

**EP AK** Cable junction box

Accessories

● **Cable junction box**

Junction box for holding a pre-assembled connector cable such as EP DK Ra Sb Kc Lxxxx.

The following variants are available:

Ordering code	Description
EP AK	Junction box with 9 pole terminal block for receptacles without pilot contact (S0)
EP AK11	Junction box with 11 pole terminal block for receptacles with pilot contact (S1)

To be mounted via 4 M10 screws at the bottom of the box, see dimension diagram.

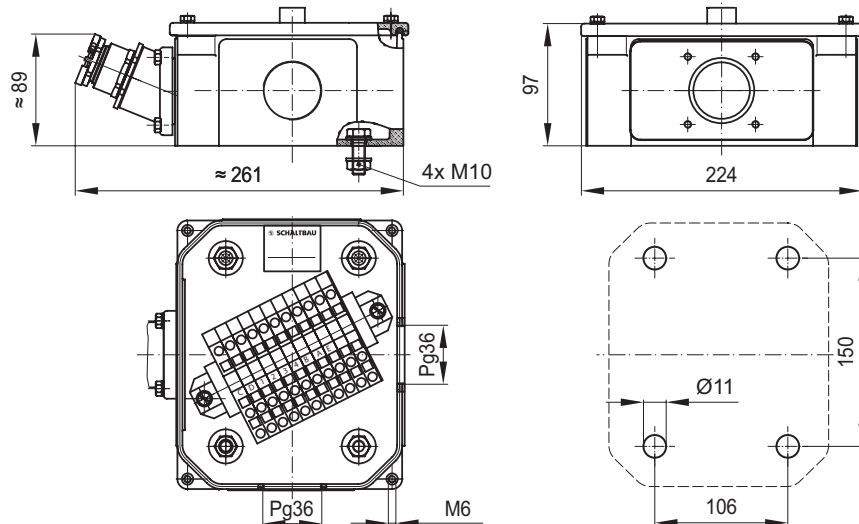

Reduced scale diagrams / dimensions in mm

## Assembly Plug and receptacle

EP Series

### Assembly of plugs

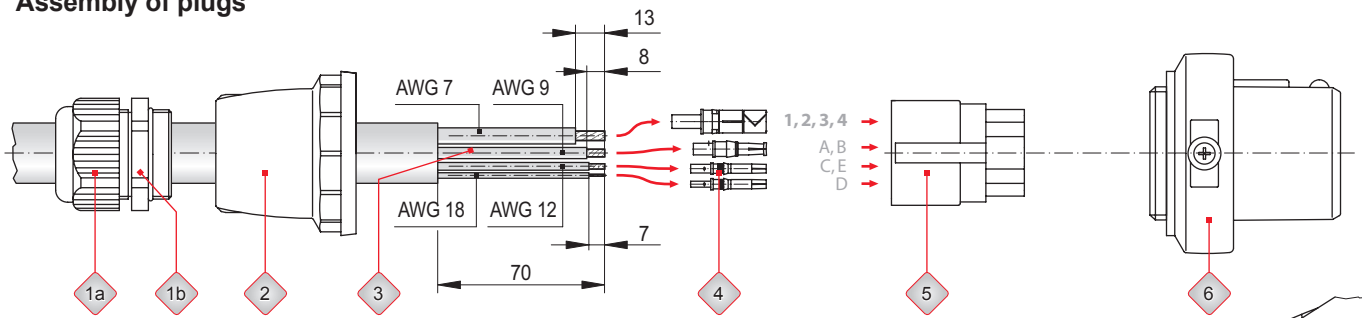

### Assembly of receptacles

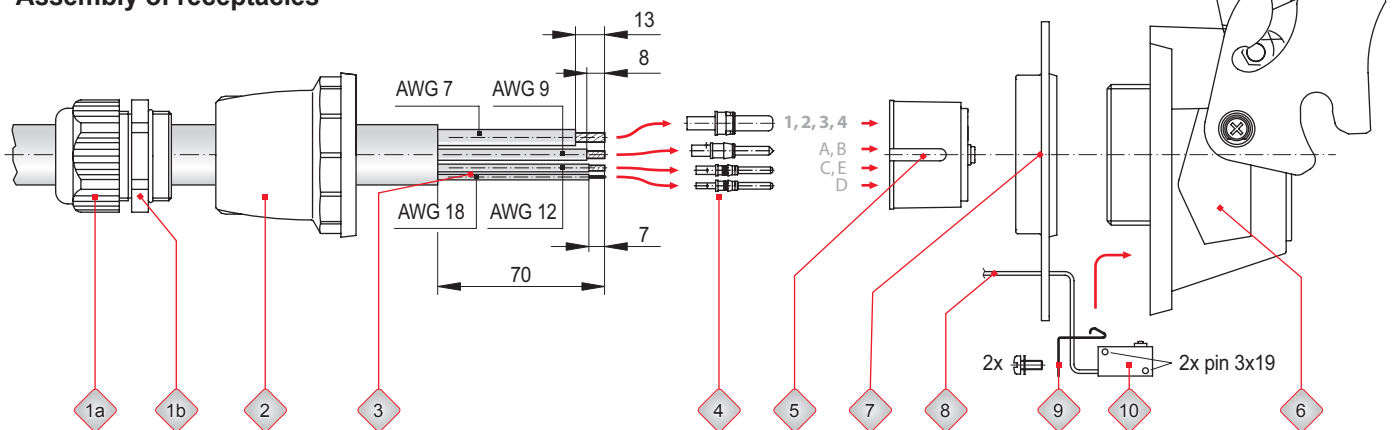

### Assembly instructions

Place cable gland with integrated strain relief (1a), (1b) and backshell (2) on cable in sequence shown. Remove part of cable jacket, trim the individual conductors (3) to the desired length and strip the insulation. Crimp cable conductors (3) to contacts (4). The edge of the insulation where the wire is stripped should abut on the point of crimping.

Fit crimped contacts (4) into contact insert (5). Make sure that clip is locked in place in contact insert. We recommend checking of the established contact. The contact retention test force is 40 N. Fit contact insert (5) into shell (6) and screw

backshell (2) to plug and receptacle shell (6) respectively. Screw part (1b) of cable gland in backshell (2) and tighten part (1a) of cable gland securely to ensure strain relief of individual conductors (depends on type of backshell; this instruction refers to type R1).

Instructions to be continued for receptacle: Mount snap-action switch (10) together with accessories (9) in receptacle and connect leads (8). Note: Make sure to secure the leads with sleeves! Press seal (7) to shell and mount receptacle and dummy receptacle respectively.

## Mounting

EP Series

### Please observe the following instructions:

- Metal plate must be earthed
- Surface finish of metal plate: Rz 6.3 ... 12.5  $\mu\text{m}$
- Terminal block for pilot contact: wire gauge 2,5 mm<sup>2</sup> max.
- Earth connection via mounting holes
- Tightening torque 15 Nm min.
- Mounting position: horizontal up to - 30°

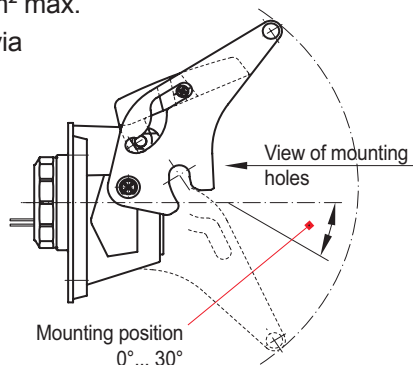

### Mounting holes of receptacle and dummy receptacle:

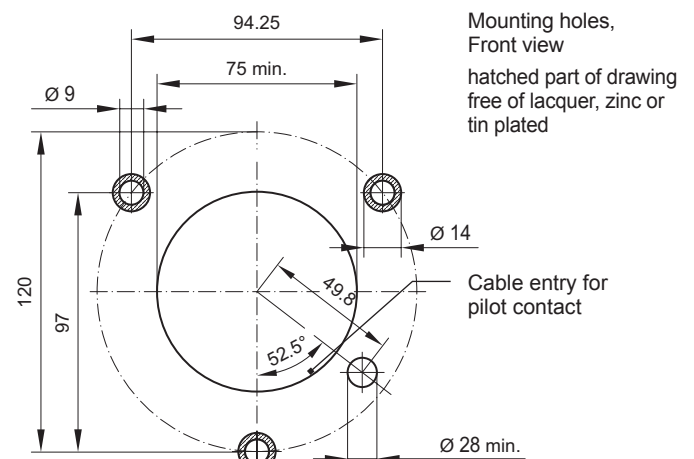





Schaltbau GmbH has an environment management system that has been certified since 1994.



Schaltbau GmbH has a quality management system that has been certified since 1994.

## Electrical Components and Systems for Railway Engineering and Industrial Applications

### Connectors

- Connectors manufactured to industry standards
- Connectors to suit the special requirements of communications engineering (MIL connectors)
- Charging connectors for battery-powered machines and systems
- Connectors for railway engineering, including UIC connectors
- Special connectors to suit customer requirements

### Snap-action switches

- Snap-action switches with positive opening operation
- Snap-action switches with self-cleaning contacts
- Enabling switches
- Special switches to suit customer requirements

### Contactors

- Single and multi-pole DC contactors
- High-voltage AC/DC contactors
- Contactors for battery powered vehicles and power supplies
- Contactors for railway applications
- Terminal bolts and fuse holders
- DC emergency stop switches
- Special contactors to suit customer requirements

### Control devices

- Master controllers and reversers for railway applications
- Toggle switch devices
- Handles and foot switches for railway applications (dead-man equipment)
- Switching elements with high breaking capacity
- Emergency brake handles
- Signal devices

### Transportation system equipment

- Power supplies for passenger coaches (electric equipment)
- Battery chargers for locomotives and passenger coaches
- High-voltage equipment for single and multi-phase operation
- Heating devices and heating controls
- Design and engineering services for high-voltage equipment
- Special equipment to suit customer requirements

## Schaltbau GmbH

Klausenburger Strasse 6  
81677 Munich  
Germany

Phone +49 89 9 30 05-0  
Fax +49 89 9 30 05-350  
e-Mail [contact@schaltbau.de](mailto:contact@schaltbau.de)  
Internet [www.schaltbau.de](http://www.schaltbau.de)

with compliments: