

REV	Description	DATE	BY
A4A	Initial production Release.	11/19/2012	GC
A5	On the initial production release the processors were to be found incorrect as supplied by TI. Parts while marked AM3359 were actually AM3352. This revision uses the correct parts.	1/2/2013	GC
A5A	<ol style="list-style-type: none"> Deleted R29-R44 from the LCD lines. Added 47pf capacitors C156-C173 to LCD data lines to ground. Changed schematic revision to A5A. Changed a few footprints after PCB update for above changes. Added access point for the battery function of the TPS65217C. Added Ferrite beads in series with LED power and 5V power rail of the USB host connector. Required to pass FCC/CE testing due to noise emissions on that pin. Added power button to enable sleep, wakeup, power down and power up features on the system. Added Modification to add 100K ohm resistor to ground to prevent crosstalk when serial cable is not plugged in. 	2/8/2013	GC
A5B	<ol style="list-style-type: none"> Added 100K pulldown on J1 pin 4 to prevent crosstalk when serial cable is not connected into PCB layout. Changed the LED resistors to 4.75K to lower the brightness. 	5/21/2013	GC
A5C	<ol style="list-style-type: none"> Changed R46, R47, R48 to 0 ohms. Changed R45 to 22 Ohms. Change was made due to production failures on some boards due to differences in impedances.	6/12/2013	GC

PAGE NO.	SCHEMATIC PAGE
1	COVER PAGE
2	POWER MANAGEMENT
3	PROCESSOR 1 OF 3, JTAG HEADER
4	PROCESSOR 2 OF 3, UAB PORTS
5	PROCESSOR 3 OF 3
6	LED, CONFIGURATION AND BUTTON
7	DDR3 MEMORY
8	eMMC FLASH
9	10/100 ETHERNET
10	HDMI FRAMER
11	EXP CONN, uSD

NOTE: PCB Revision for this board is Rev B4.

This schematic is ***NOT SUPPORTED*** and DOES NOT constitute a reference design. Only "community" support is allowed via resources at BeagleBoard.org/discuss.

THERE IS NO WARRANTY FOR THIS DESIGN , TO THE EXTENT PERMITTED BY APPLICABLE LAW. EXCEPT WHEN OTHERWISE STATED IN WRITING THE COPYRIGHT HOLDERS AND/OR OTHER PARTIES PROVIDE THE DESIGN "AS IS" WITHOUT WARRANTY OF ANY KIND, EITHER EXPRESSED OR IMPLIED, INCLUDING, BUT NOT LIMITED TO, THE IMPLIED WARRANTIES OF MERCHANTABILITY AND FITNESS FOR A PARTICULAR PURPOSE. THE ENTIRE RISK AS TO THE QUALITY AND PERFORMANCE OF THE DESIGN IS WITH YOU. SHOULD THE DESIGN PROVE DEFECTIVE, YOU ASSUME THE COST OF ALL NECESSARY SERVICING, REPAIR OR CORRECTION.



beagleboard.org

Title		BeagleBone Black Cover Page	
Size	Document Number	Rev	
B	450-5500-001	A5C	
Date:	Wednesday, June 12, 2013	Sheet	1 of 11

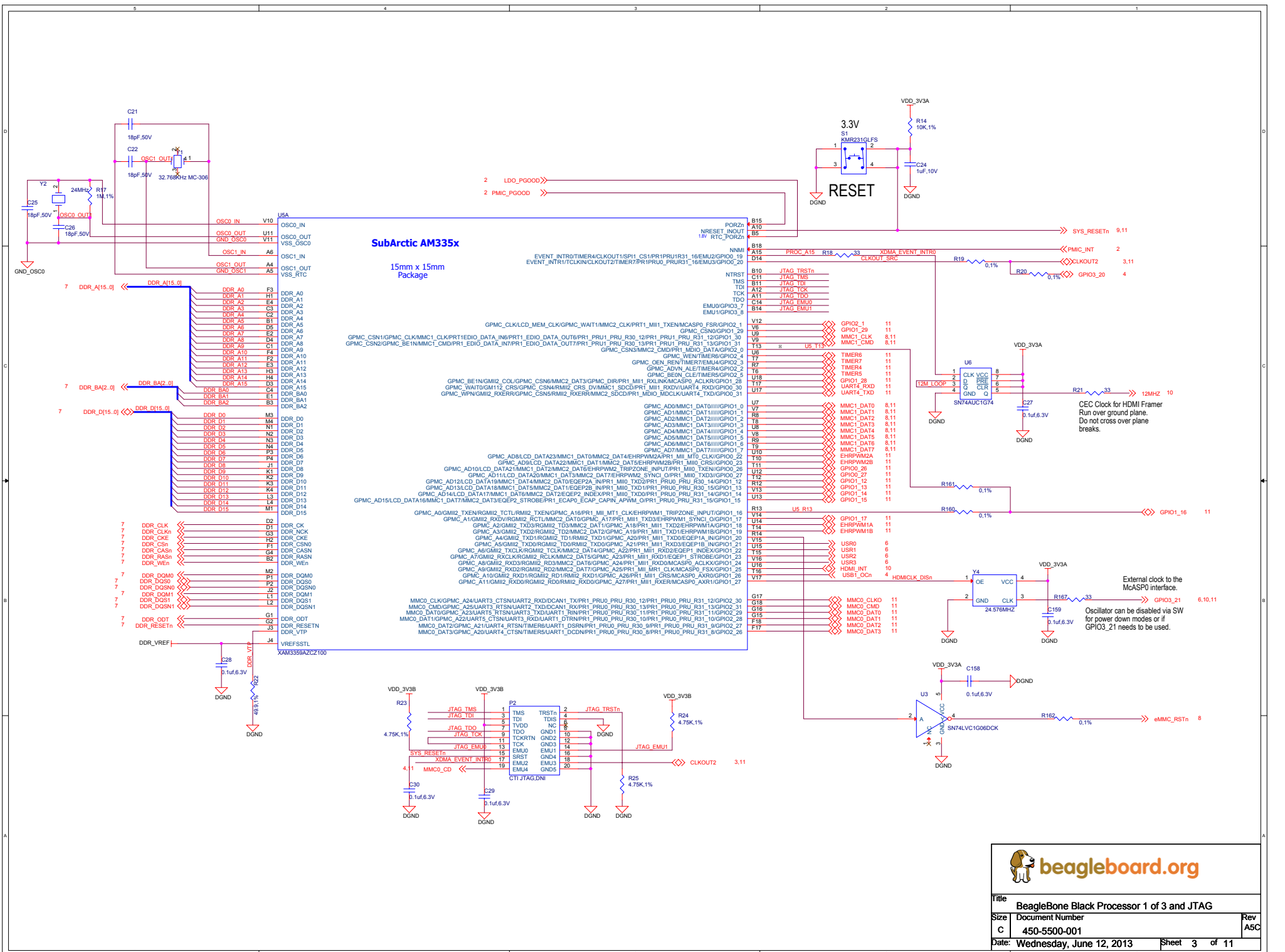

Title	BeagleBone Black Processor 1 of 3 and JTAG	
Size	Document Number	Rev
C	450-5500-001	ASC
Date:	Wednesday, June 12, 2013	Sheet 3 of 11

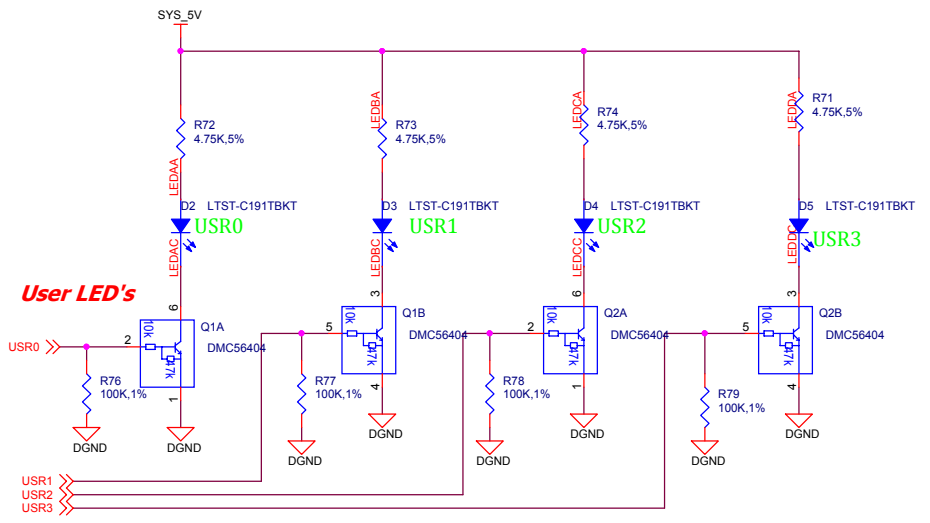
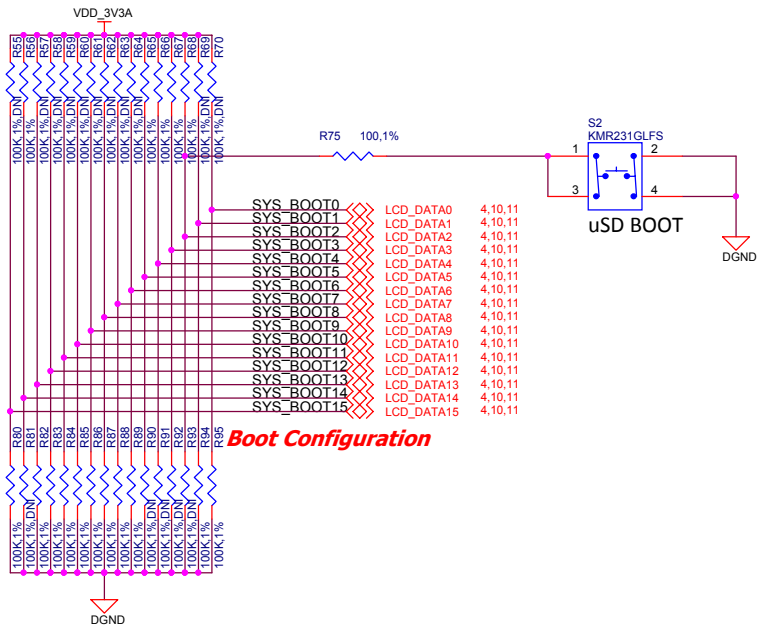

SYSBOOT[15:14]	SYSBOOT[13:12]	SYSBOOT[11:10]	SYSBOOT[9]	SYSBOOT[8]	SYSBOOT[7:6]	SYSBOOT[5]	SYSBOOT[4:0]	Boot Sequence			
00b = 19.2MHz 01b = 24MHz 10b = 25MHz 11b = 26MHz	00b (all other values reserved)	Don't care for ROM code	Don't care for ROM code	Don't care for ROM code	Don't care for ROM code	0 = CLKOUT1 disabled 1 = CLKOUT1 enabled	11100b	MMC1	MMC0	UART0	USB0[5]
00b = 19.2MHz 01b = 24MHz 10b = 25MHz 11b = 26MHz	00b (all other values reserved)	Don't care for ROM code	Don't care for ROM code	Don't care for ROM code	Don't care for ROM code	0 = CLKOUT1 disabled 1 = CLKOUT1 enabled	11000b	SPI0	MMC0	USB0[5]	UART0



Title		
BeagleBone Black LED, Configuration, and Reset		
Size	Document Number	Rev
B	450-5500-001	A5C
Date:	Wednesday, June 12, 2013	Sheet 6 of 11

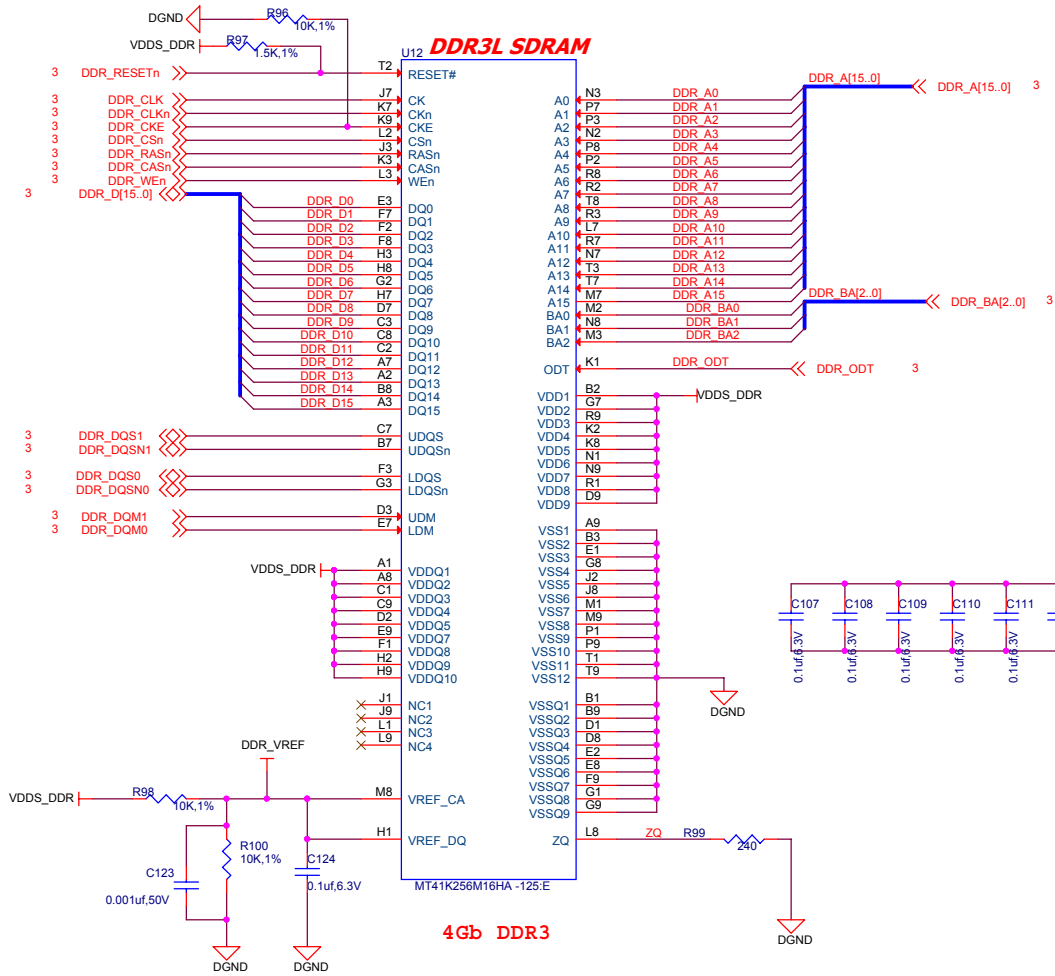

Title		
BeagleBone Black DDR3 Memory		
Size	Document Number	Rev
B	450-5500-001	A5C
Date:	Wednesday, June 12, 2013	Sheet 7 of 11

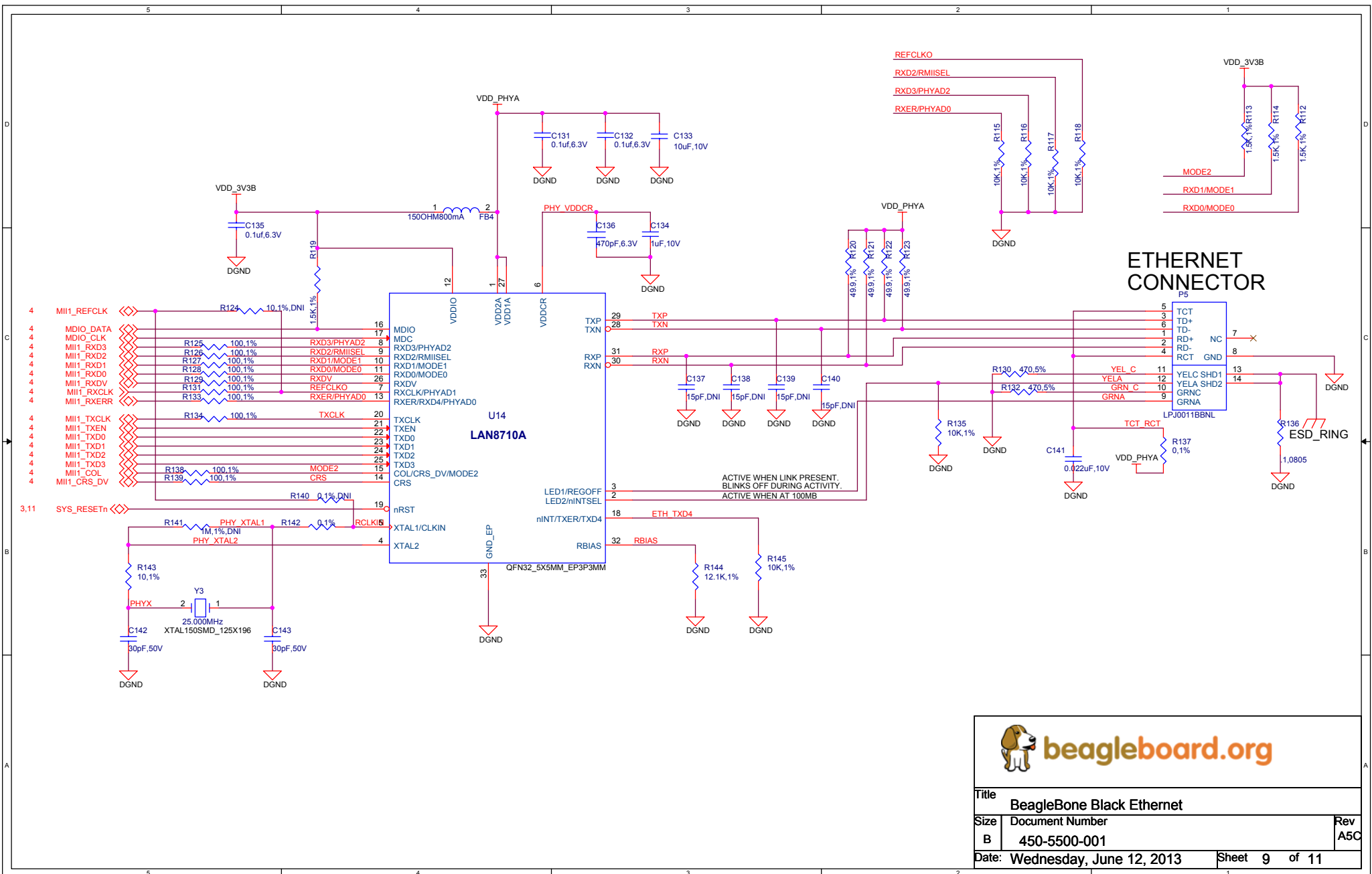

ETHERNET CONNECTOR



beagleboard.org

Title		BeagleBone Black Ethernet	
Size	Document Number		Rev
B	450-5500-001		A5C
Date:	Wednesday, June 12, 2013	Sheet	9 of 11

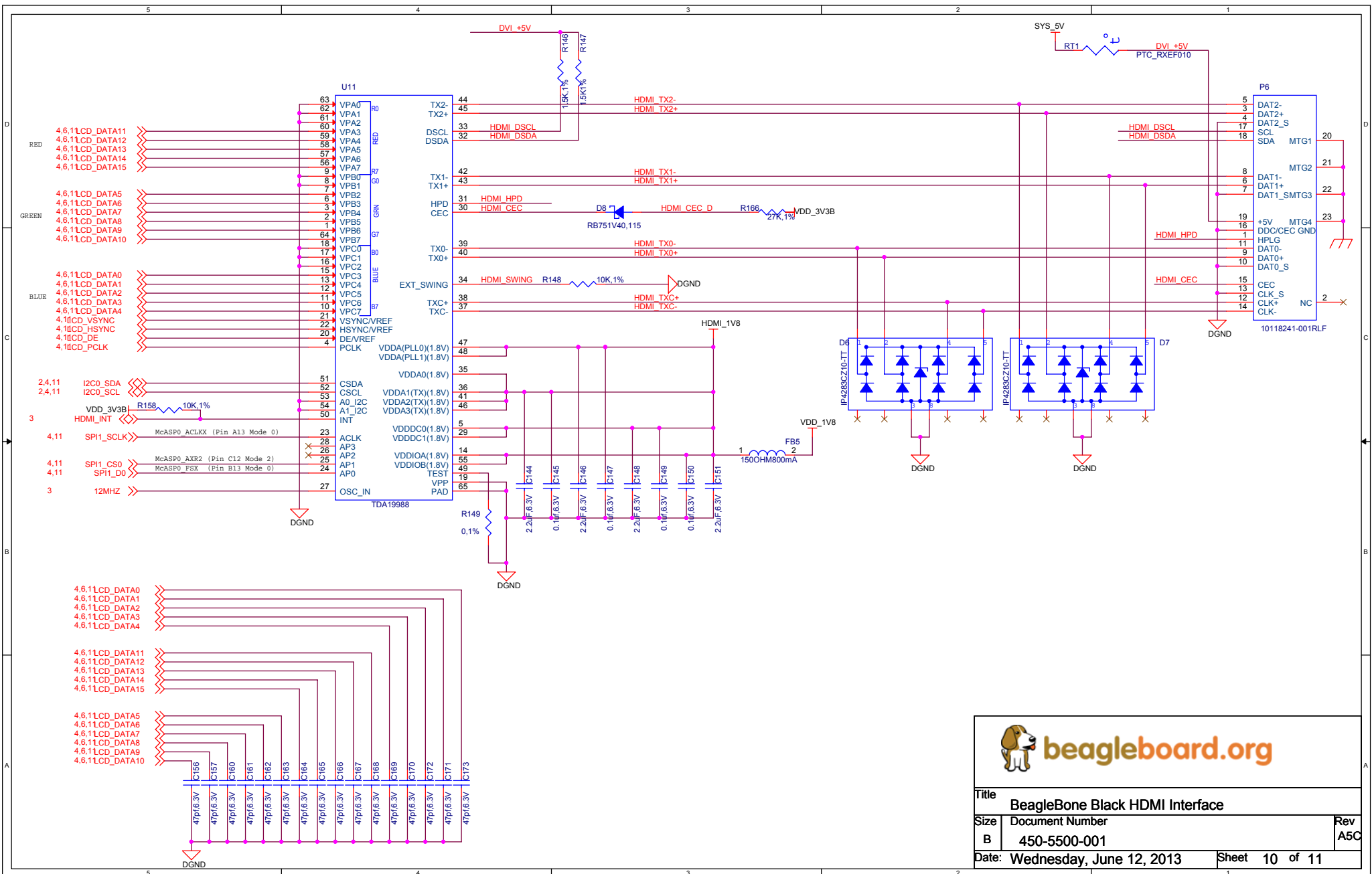

Title		
BeagleBone Black HDMI Interface		
Size	Document Number	Rev
B	450-5500-001	A5C
Date:	Wednesday, June 12, 2013	Sheet 10 of 11

