

HKD XKC-Y25 LIQUID LEVEL SENSOR

Product Introduction:

- 1.Input Voltage: DC 5-12V
- 2.Power Consumption: 5mA
- 3.Output Voltage (high level): InVCC
- 4.Output Voltage (low level): 0V
- 5.Output Current: 1-50mA
- 6.Response Time: 500ms
- 7.Operating Ambient Temperature: 0~100 Celsius
- 8.Sensor Thickness (sensitivity) Range: 0-20mm
- 9.Communication: NPN
- 10.Humidity: 5%-100%
- 11.Material: ABS
- 12.Waterproof Performance: IP67
13. Cable length: 50cm

Operating Principle:

Intelligent non-contact liquid level sensor is for detecting whether there is liquid by water induction capacitor.

When there is no liquid to approach the sensor, sensor will generate certain static capacitance because of the capacitor distribution.

When the liquid rises slowly to approach the sensor, the liquid parasitic capacitor will coupling to this static capacitor so that the terminal capacitance of sensor will increase.

The changing capacitance signal will be input to control IC and achieve signal switch, then transform the changing capacitance value into variation of certain electric signal.

Using certain algorithm to detect and judge the degree of the variation; when the variation has surpassed certain threshold value, then it means the liquid level reaches sensing point.

Features:

1. It is applicable to non-metal outer wall not necessary to directly contact with liquid so that it can avoid liquid corrosion of strong acid or alkali, or the influence by scale or other impurities.
2. Intelligent liquid level benchmark adjustment and liquid level memory function, liquid level status display way, it can achieve multi-point serial connection; support NPN output.
3. Accurate and stable detection, it can detect boiling water liquid surface.
4. Pure electronic structure, non-mechanical operation way; and it has stable performance and long life.
5. High stability, high sensitivity, strong anti-interference capacity; it will not be affected by power frequency interference and common mode interference due to special disposals so as to compatible with 5-24V power adapter.
6. Strong compatibility, and it can penetrate into non-metal tube, such as plastic, glass, ceramic etc. Its sensing tube wall thickness can be up to 12mm; liquid, powders, particulates all can be detected.
7. Open collector output way, wide range of voltage (5-24V), and it is applicable to connect various circuit and product applications.

Connection Introduction:

- 1.Brown wire (VCC); power 5-24V (connects power positive)
- 2.Yellow (OUT); signal output
- 3.Black wire (M); output level (positive output or negative output) control
When black wire connects high level, yellow wire is positive output signal wire; if there is induction, it will output high level (NPN-operate);

if there is no induction, it will output low level (NPN-disconnect)

When black wire connects low level, yellow wire is negative output signal wire; if there is induction, it will output low level (NPN-disconnect);

if there is no induction, it will output high level (NPN-operate)

4. Blue wire (GND); ground wire (connects power negative)

Sensitivity Adjustment:

- 1. Open the back cover of the sensor head, use small screwdriver to adjust the sensitivity knob
- 2. If counter clockwise rotate the knob, it will increase sensitivity, otherwise, it will decrease the sensitivity.

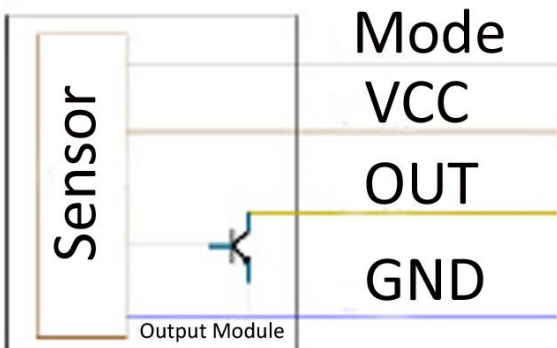
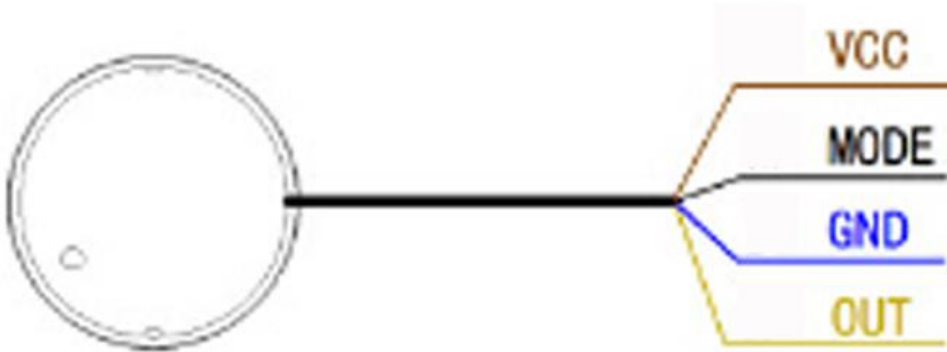
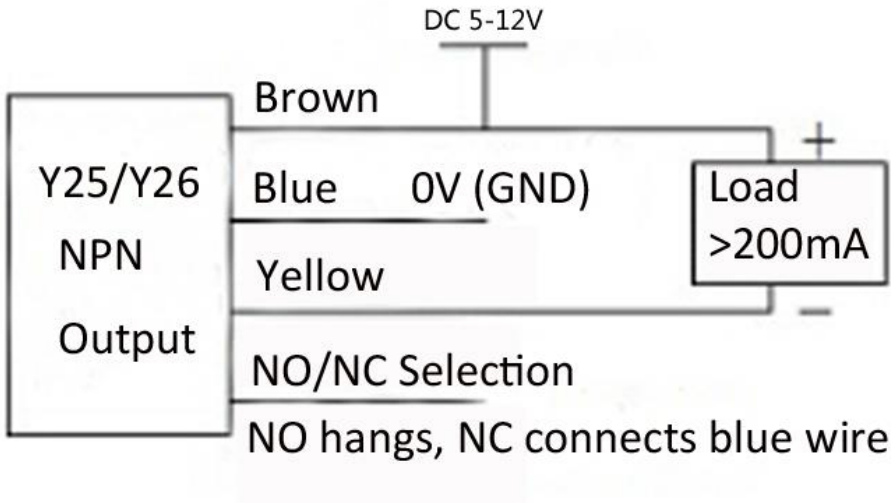

Output Principle

