

Top View of Assembly

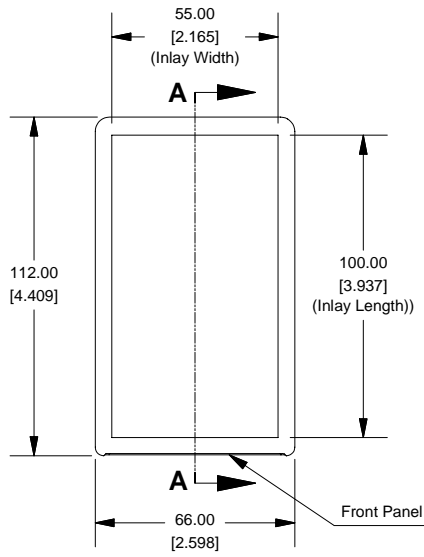

SECTION A-A (Side View Inside Assembly)

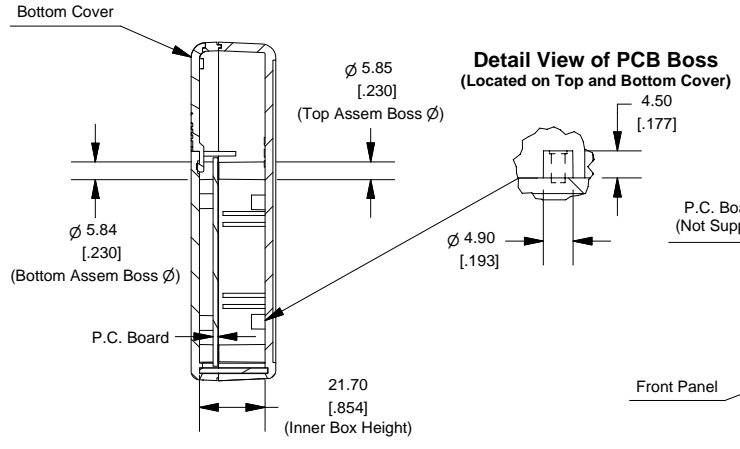

Detail View of PCB Boss (Located on Top and Bottom Cover)

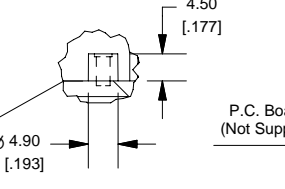

Hand Held Instrument (1593Q)

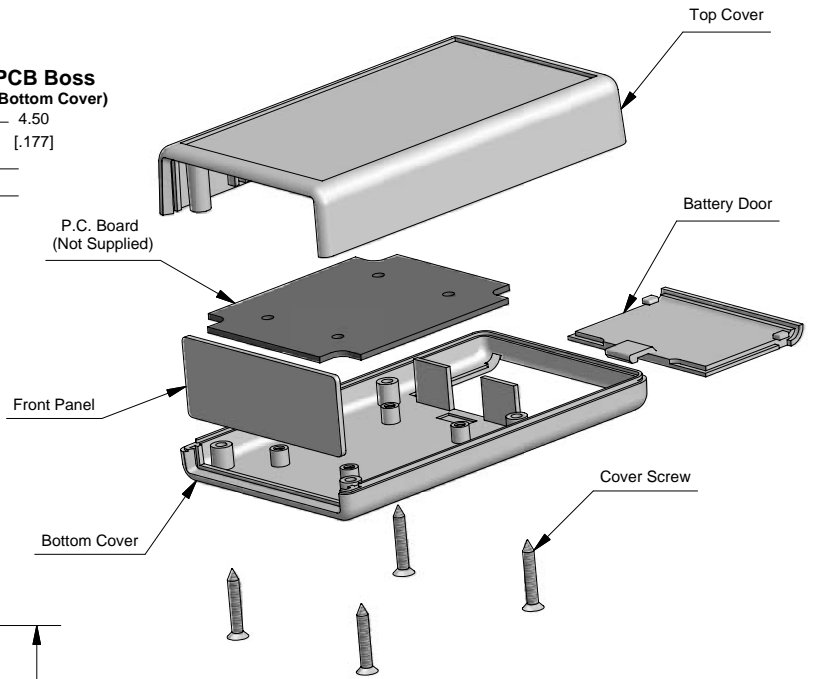

End View of Assembly

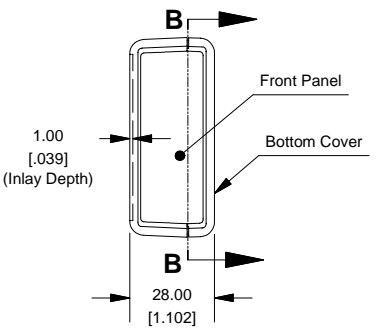

SECTION B-B (Inside of Bottom Cover)

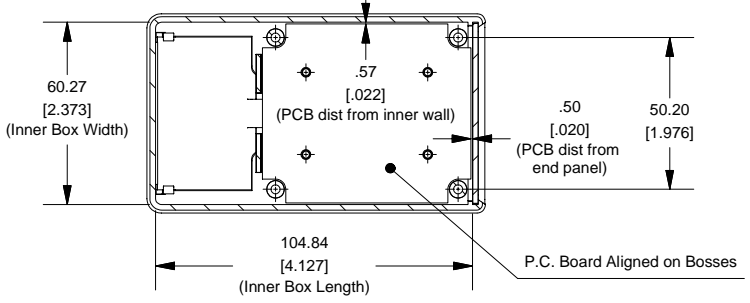

NOTE
Purchased assembly includes top and bottom cover, front panel (plastic), battery door and 4 cover screws.

| PART NUMBERS | |
|---|--|
| 1593Q Enclosure | |
| Black Enclosure | 1593QBK |
| Grey Enclosure | 1593QGY |
| ACCESSORIES | |
| Cover Screws (Pkg 100) [#4 x 3/4" self-tapping oval head (19.1mm)] | 1593QS100 |
| P.C. Board Screws [#4 x 1/4" self-tapping (6.4mm)] | 1593ATS50 (Pkg 50) 1593ATS100 (Pkg 100) |
| Belt or Pocket Clip | 1599CLIP (Black) 1599CLIPGY (Grey) |
| Infrared Panels (Pkg 10) | 1593PIR10 |
| Battery Holder Kit for: | |
| 1 AA Cell | BH1AAWKIT |
| 2 AA Cells | BH2AAWKIT |
| 1 AAA Cell | BH1AAWKIT |
| 2 AAA Cells | BH2AAWKIT |
| 3 AAA Cells | BH3AAWKIT |
| 4 AAA Cells | BH4AAWKIT |
| 1 - 9V Cell | BS61KIT |

Front/Rear Panel (Dashed Line Indicates Viewing Area)

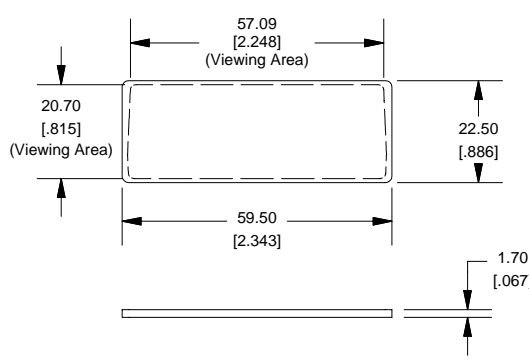

Maximum P.C. Board Size

