

# USR-CANET200 User Manual

File Version: V1.0.4.01



## Contents

USR-CANET200 User Manual .....	1
Features .....	3
1.Get Start .....	4
1.1.Application Diagram .....	4
1.2.Hardware design .....	4
1.2.1.LED .....	4
1.2.2.Dimension .....	5
2.Product function .....	6
2.1.Basic function .....	6
2.1.1.Static IP/DHCP .....	6
2.1.2.Restore default settings .....	7
2.2.CAN .....	7
2.2.1.CAN basic parameters.....	7
2.2.2.CAN package method .....	7
2.2.3.CAN ID filtering.....	7
2.2.4.CAN data transparent transmission protocol.....	8
2.3.Serial port.....	9
2.3.1.Serial port basic parameters.....	9
2.3.2.Serial package method .....	9
2.4.Socket function.....	9
2.4.1.TCP Client mode .....	9
2.4.2.TCP Server mode .....	10
2.4.3.UDP Client mode.....	10
2.4.4.UDP Server mode .....	11
2.5.Features .....	11
2.5.1.Heartbeat packet function .....	11
2.5.2.Identity packet function.....	12
2.5.3.USR Cloud function .....	12
2.5.4.CAN relaying function.....	13
3.Parameter configuration .....	14
3.1.Setup software .....	14
3.2.Web Server .....	14
3.3.AT command .....	14
3.3.1.Serial AT command mode.....	14
3.3.2.Network AT command mode .....	15
4.Contact Us.....	15
5.Disclaimer.....	16
6.Update History .....	16

## Features

- All-around hardware protection. CAN, serial port, Ethernet interface and power interface all have high-level protection to adapt harsh industrial environment.
- 10/100Mbps Ethernet interface. Support Auto-MDI/MDIX.
- Support CAN ID filtering function, various filtering function make using module more secure.
- One port supports two sockets.
- CAN baud rate ranges from 10K~1Mbps; support BASIC and LOOPBACK work modes.
- Support static IP function or DHCP function; support searching device in network by UDP broadcast.
- Support restoring default settings by Rebad button.
- RJ45 has Link/Data LED; Ethernet interface has external isolation transformer and supports 1.5KV electromagnetic isolation.
- Support upgrading firmware by network.
- Support modifying Web Server port(Default is 80).
- Support Keep-Alive function.
- Support CAN relay function.
- Support switching between CAN and RS485.

## 1. Get Start

If user has any question, please submit it back to customer center: <http://h.usriot.com>.

### 1.1. Application Diagram

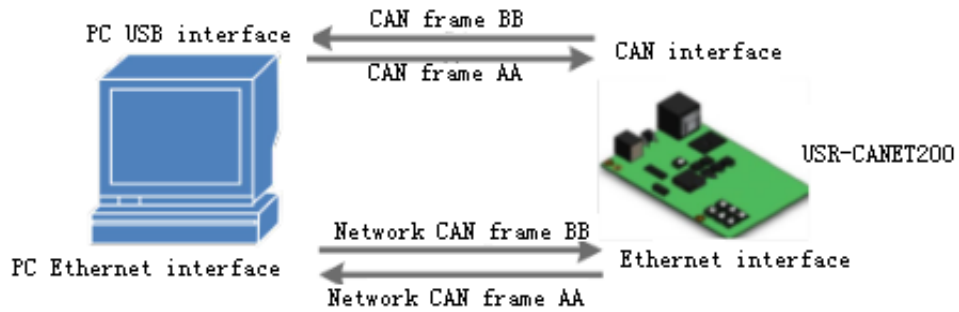

Figure 1 Application diagram

## 1.2. Hardware design

### 1.2.1. LED



LED	Description
Power	Power LED will light after powering the module successfully
Work	Work LED will blink if module works normally. And Work LED will off or light when module works abnormally.
CAN1	Dual colour. When module transmits data, CAN1 LED will blink in red; when module receives data, CAN1 LED will blink in blue.
CAN2	Dual colour. When module transmits data, CAN2 LED will blink in red; when module receives data, CAN2 LED will blink in blue.
RS485	Dual colour. When module transmits data, RS485 LED will blink in red; when module receives data, RS485 LED will blink in blue.

Figure 2 LED

### 1.2.2.Dimension

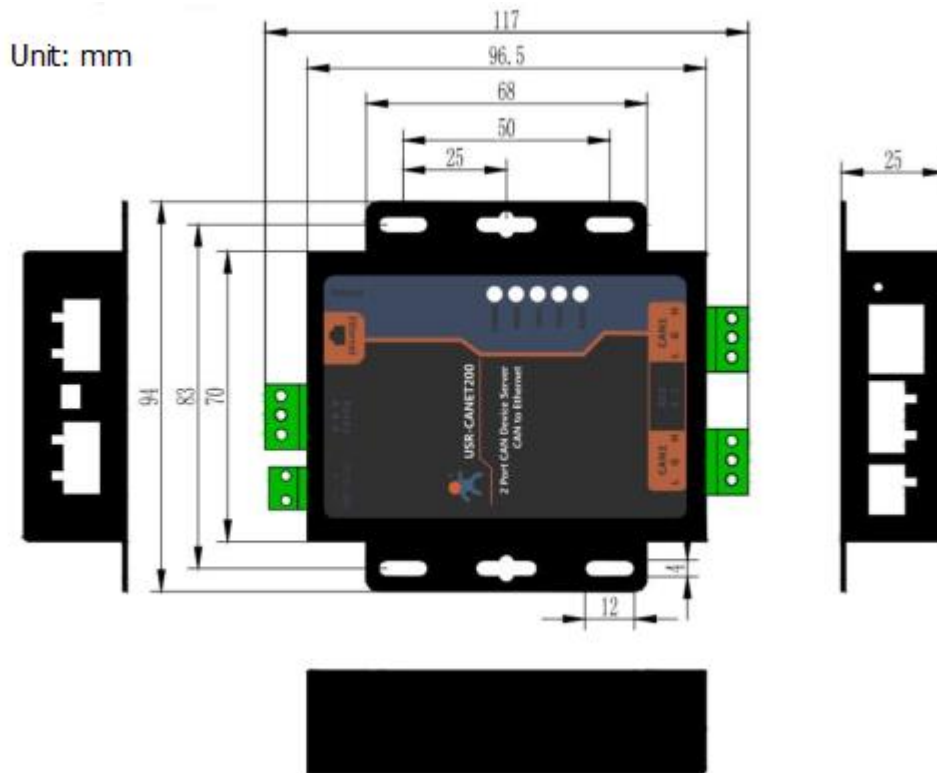
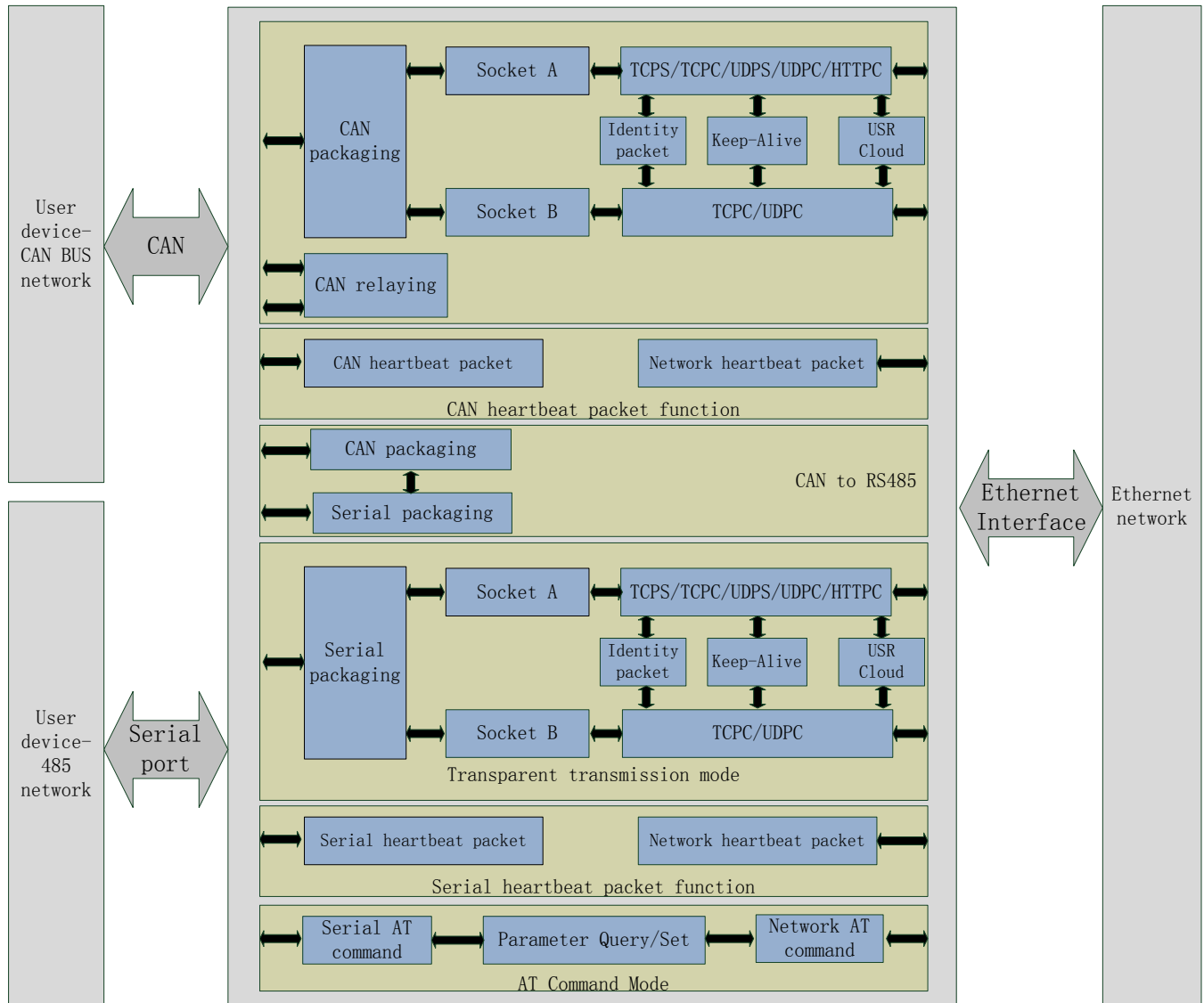

Figure 3 Dimension

## 2. Product function

This chapter introduces the functions of USR-CANET200. As the following diagram shows, user can get an overall knowledge of it.



**Figure 4 Product functions diagram**

### 2.1. Basic function

#### 2.1.1. Static IP/DHCP

There are two ways for module to get IP address: Static IP and DHCP.

**Static IP:** Default setting of module is Static IP and default IP is 192.168.0.7. When user configures module in Static IP mode, user needs set IP, subnet mask and gateway and must pay attention to the relation among IP, subnet mask and gateway.

**DHCP:** Module in DHCP mode can dynamically get IP, Gateway, and DNS server address from Gateway Host. When

user connects CANET200 directly to PC, module can't be set in DHCP mode. Because common computer does not have the ability to assign IP addresses.

### 2.1.2.Restore default settings

Hardware restore: User can restore default settings by hardware method. After powering module, user can press Reload button 3 seconds to 15 seconds and then release it to restore default settings.

Software restore: User can also restore default settings through setup software.

AT command restore: User can send AT+RELD in AT command mode and after receiving correct return, module will restore default settings.

## 2.2.CAN

### 2.2.1.CAN basic parameters

Parameters	Range
Baud Rate	10K~1Mbps
Work mode	Normal mode: In normal mode, CAN interface can receive and transmit data normally. Loopback mode: In loopback mode, transmitted data will be received by itself and also be transmitted to CAN bus network, but data can't be transmitted to module. This mode is used to test.

Figure 5 CAN basic parameters

### 2.2.2.CAN package method

Data transmission is based on data frame in network side, so CAN interface data need to be packaged into data frame and then transmit to network side. There are 2 ways to end the package and send package to network side - Time Trigger Mode and Length Trigger Mode(When CAN interface data meet any one condition, they will be packaged):

- CANET200 CAN package time: Default is 10ms, range from 1 to 255.
- CANET200 CAN package length: Default is 50 frames, range from 1 to 50.

### 2.2.3.CAN ID filtering

CAN ID filtering includes following four modes:

- Extended frame receiving range: In this mode, module will only receive extended frame ID in the range and filter standard frame.
- Extended frame filtering range: In this mode, module will only filter extended frame ID in the range and completely receive standard frame.
- Standard frame receiving range: In this mode, module will only receive standard frame ID in the range and filter extended frame.
- Standard frame filtering range: In this mode, module will only filter standard frame ID in the range and completely receive extended frame.

**Note:** All ranges include boundary.

## 2.2.4.CAN data transparent transmission protocol

### 1.Byte conversion

CAN data transfer to Ethernet data: Transfer CAN ID and data to 13 bytes network data.

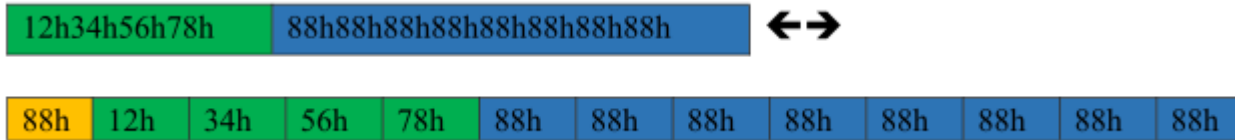

### 2.Frame information

88h

Frame information length is 1 byte and is used to identify some frame information such as: frame type, frame length.

Bit7				Bit0			
FF	RTR	Reserved	Reserved	B3	B2	B1	B0

- FF: Identifying bit to identify standard frame and extended frame, 1 is extended frame and 0 is standard frame.
- RTR: Identifying bit to identify remote frame and data frame, 1 is remote frame and 0 is data frame.
- Reserved: Reserved bit needs to be 0.
- B3~B0: Data length bit to identify CAN frame length.

### 3.Frame ID

12h 34h 56h 78h

Four bytes, high-order bit is former and low-order bit is latter.

12h 34h 56h 78h

Extended frame ID: 0x12345678

00h 00h 01h 23h

This ID can be standard frame ID or extended frame ID(Standard frame ID or extended frame ID is identified by frame information):

- Extended frame ID: 0x00000123
- Standard frame ID: 0x0123

### 4.Frame data

88h 88h 88h 88h 88h 88h 88h 88h

Eight bytes. Effective length is expressed by B3~B0 of frame information and insufficient bits will be supplied by 00h.

For example:

CAN to Ethernet: CAN side transmit data(Frame format: extended frame; frame type: data frame; ID: 12345678; data: 12 34 56 78 00) and Ethernet side will receive: 85 12 34 56 78 12 34 56 78 00 00 00 00. 0x85 means frame format is extended frame, frame type is data frame and data length is 5; '12 34 56 78' are CAN ID; '12 34 56 78 00 00 00 00' are data with effective length 5 and the rest bits are supplied with 0.

Ethernet to CAN: Ethernet side transmit: 05 00 00 06 78 12 34 56 78 00 00 00 00. 0x05 means standard frame,



data frame and data length is 5; 00 00 06 78 means CAN ID is 0678; 12 34 56 78 00 00 00 00 are data with effective length 5.

## 2.3.Serial port

### 2.3.1.Serial port basic parameters

Parameters	Range
Baud Rate	600~115.2Kbps
Data Bits	5, 6, 7, 8
Stop Bits	1, 2
Parity Bits	None, Odd, Even, Mark, Space

Figure 6 Serial port basic parameters

### 2.3.2.Serial package method

Data transmission is based on data frame in network side, so serial data need to be packaged into data frame and then transmit to network side. There are 2 ways to end the package and send package to network side - Time Trigger Mode and Length Trigger Mode(When serial data meet any one condition, they will be packaged):

- CANET200 serial package time: Default is 10ms, range from 1 to 255.
- CANET200 serial package length: Default is 500 bytes, range from 1 to 1460.

## 2.4.Socket function

CANET200 supports dual sockets mode(Socket A and Socket B). Socket A supports TCP Server, TCP Client, UDP Server, UDP Client. Socket B supports TCP Client and UDP Client.

### 2.4.1.TCP Client mode

TCP Client provides Client connections for TCP network services. TCP Client device will connect to server to realize data transmission between the serial port device/CAN bus network device and server. According to the TCP protocol, TCP Client has connection/disconnection status differences to ensure reliable data transmission.

TCP Client mode supports Keep-Alive function: After establishing connection, CANET200 will send Keep-Alive packet in every 30 seconds to check TCP connection and CANET200 will disconnect and reconnect to server if any connection exception occurs. TCP Client mode also supports USR Cloud.

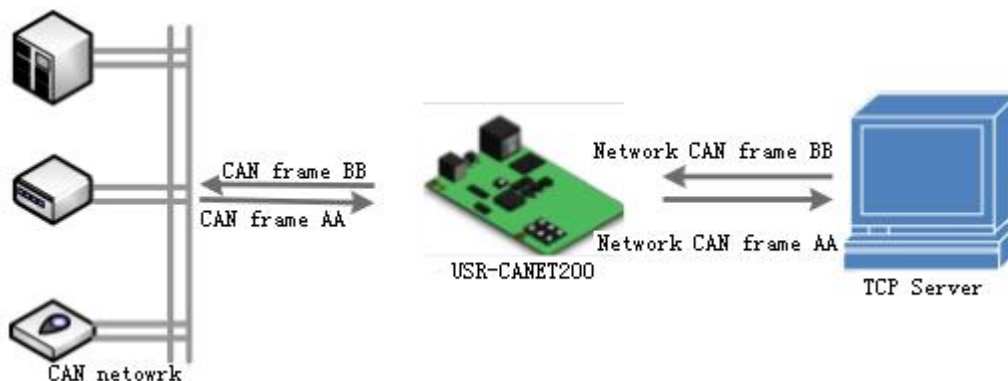

Figure 7 TCP Client mode

## 2.4.2. TCP Server mode

CANET200 works in TCP Server mode will listen network connections and build network connections, commonly be used for communication with TCP clients on a LAN. According to the TCP protocol, TCP Server has connection/disconnection status differences to ensure reliable data transmission.

CANET200 works in TCP Server mode will listen local port which user set and build connection after receiving connection request. Data will be sent to all TCP Client devices which connect to CANET200 in TCP Server mode simultaneously. TCP Server mode also supports Keep-Alive function.

Socket of CAN interface supports at most 4 Client connections in TCP Server mode and socket of serial port supports at most 1 Client connection in TCP Server mode.

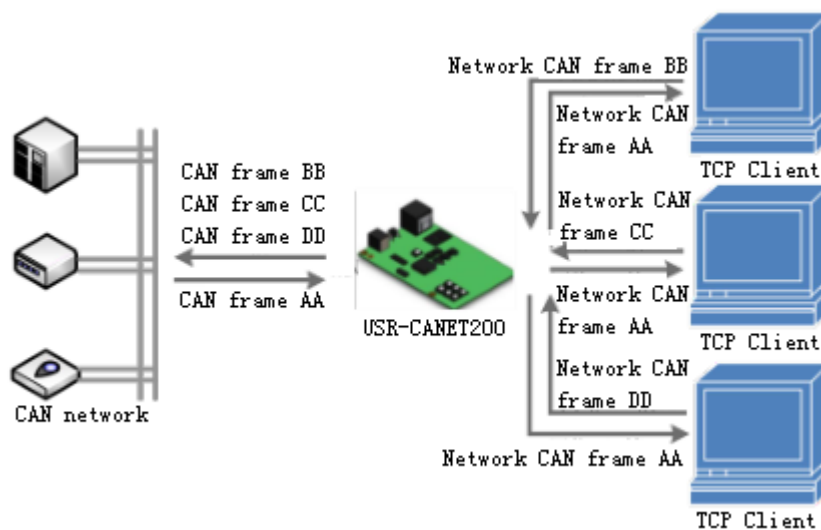

Figure 8 TCP Server mode

## 2.4.3. UDP Client mode

UDP transport protocol provides simple and unreliable communication services. No connection connected /disconnected. User only needs to configure Remote IP/Port then can realize data transmission.

In UDP Client mode, CANET200 will only communicate with Remote IP/Port. If data don't from Remote IP/Port, it won't be received by CANET200.

In UDP Client mode, if user configure Remote IP to 255.255.255.255, CANET200 can achieve UDP broadcast to all network segment and receive broadcast data. User can also configure Remote IP to xxx.xxx.xxx.255 to realize UDP broadcast in same network segment.

In UDP mode, data packet size is suggested to less than 650 bytes(50 CAN frame) and UDP packet be transmitted in every second is suggested to less than 4000 CAN frame.

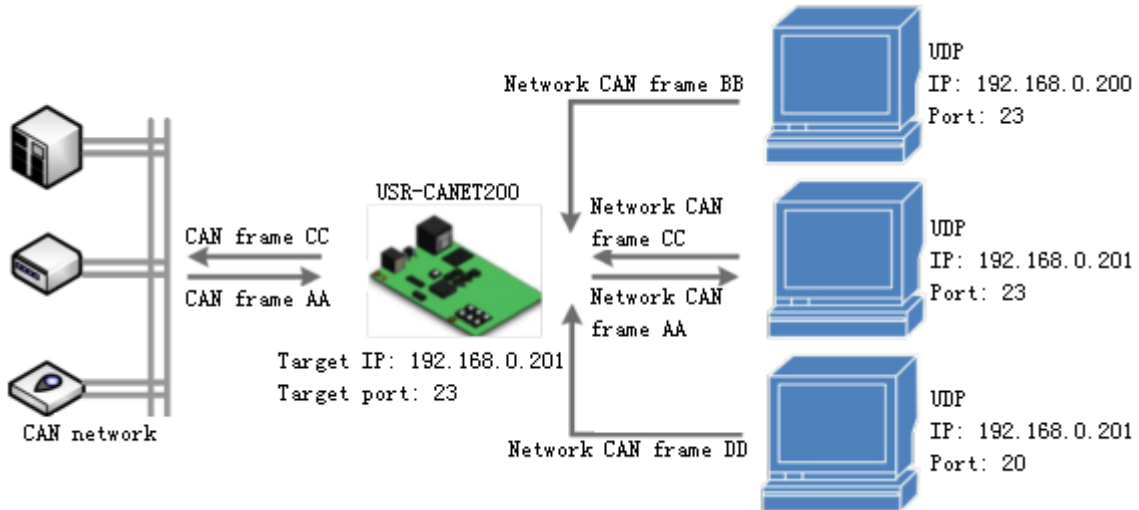

**Figure 9 UDP Client mode**

### 2.4.4.UDP Server mode

In UDP Server mode, CANET200 will change Remote IP every time after receiving UDP data from a new IP/Port and will send data to latest communication IP/Port.

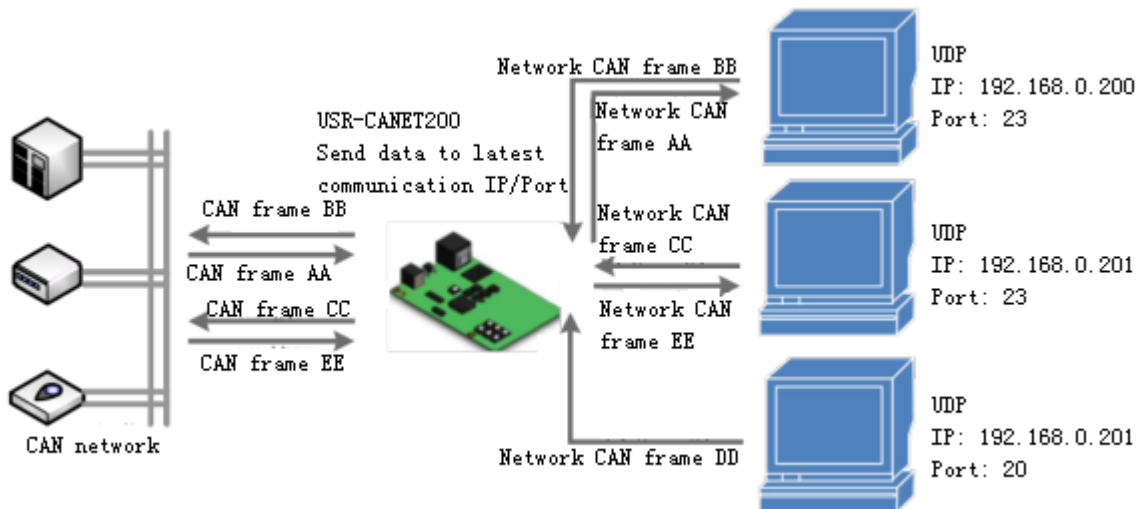

**Figure 10 UDP Server mode**

## 2.5.Features

### 2.5.1.Heartbeat packet function

Heartbeat packet: In transparent transmission mode, module can output heartbeat packet to serial/CAN side or network side periodic. User can configure the heartbeat packet data and sending interval.

- Serial heartbeat packet: Can be used as querying commands to send to serial port. Maximum size of serial heartbeat packet is 40 bytes.
- Network heartbeat packet: Can be used for showing connection status and keeping the connection (Can only take effect in TCP/UDP Client mode). Network heartbeat packet related to CAN interface should in CAN frame format.
- CAN heartbeat packet: Can be used as querying commands to send to CAN interface. CAN heartbeat packet

must conform to CAN to Ethernet data protocol.

Both two CAN interface support CAN or network heartbeat packet and heartbeat packet must conform to CAN to Ethernet data protocol.

### 2.5.2. Identity packet function

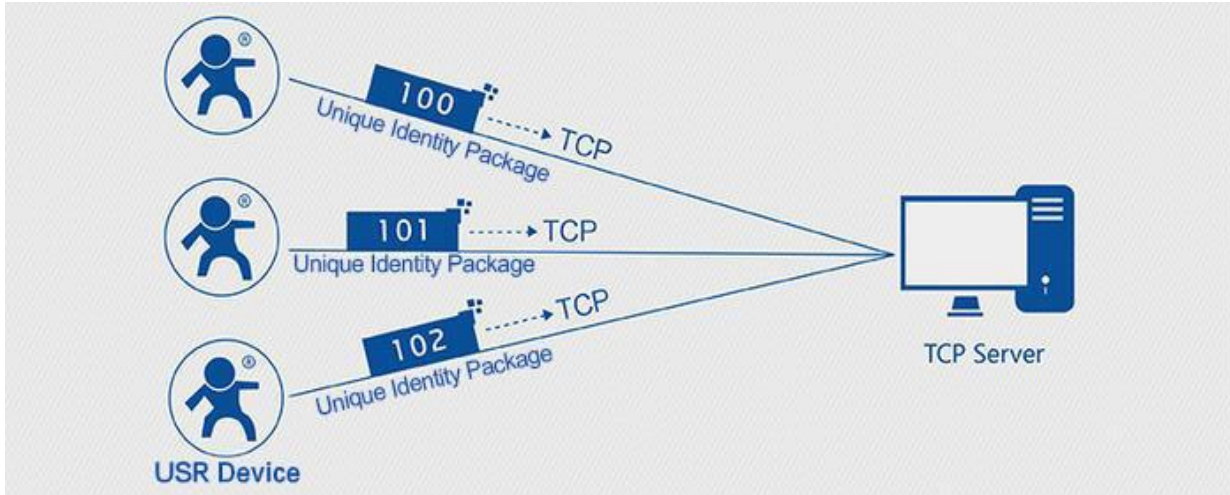

**Figure 11 Identity packet application diagram**

When CANET200 works in TCP Client or UDP Client mode, user can enable identity packet function to send identity packet to network server side. Identity packet is used for identifying the device when module works as TCP Client or UDP Client. There are two methods to send identity packet.

- Identity packet will be sent after connection is established.
- Identity packet will be added on the front of every data package.

Identity packet can be 6 bytes MAC address identity packet, user editable identity packet (less than 40 bytes) or USR Cloud identity packet. MAC address identity packet and user editable identity packet can be sent by above both methods, but USR Cloud identity packet can be only sent after connection is established.

### 2.5.3. USR Cloud function

USR Cloud application diagram as follow:



**Figure 12 USR Cloud**

USR Cloud is a platform to realize bidirectional communication between devices or device and upper computer. USC Cloud can be widely applied various domains such as remote monitoring, Internet of Vehicles, smart home, etc.

User needs to enable USR Cloud by using identity packet function. And when user enables USR Cloud function, user had better enable only one TCP Client, because both socket A and socket B support USR Cloud function, and two Clients maybe exclude each other if two Clients both connect to USR Cloud platform.

## 2.5.4.CAN relaying function

CAN relaying function can increase CAN network communication distance, change CAN network communication architecture, extend CAN network range.

When user enables CAN relaying function, CAN to Ethernet, CAN to serial port, and serial port to Ethernet will disable. Received data of CAN1 will transmit directly by CAN2 and received data of CAN2 will transmit directly by CAN1. User can also realize baud rate conversion by configuring different baud rate.

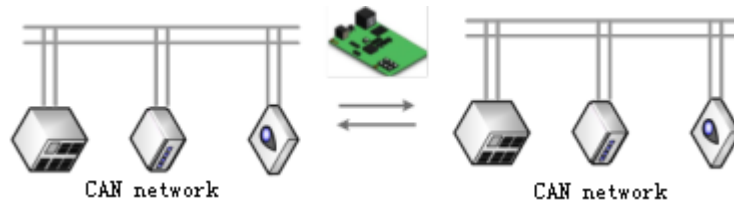

**Figure 13 CAN relaying function**

## 3.Parameter configuration

There are three ways to configure USR-CANET200. They are setup software, Web Server and AT command.

**Note:** When user configures USR-CANET200 through network(Web Server, network AT command or setup software by network), user should connect USR-CANET200 directly to PC or connect USR-CANET200 to same router as PC(When user connects USR-CANET200 to same router as PC, user should configure USR-CANET200 into DHCP mode or change static IP into same network segment as router).

### 3.1.Setup software

We provide setup software for USR-CANET200 to configure by serial or network and when user uses setup software, please close firewall and antivirus program.

### 3.2.Web Server

Web Server default parameters as follows:

Parameter	Default settings
Web Server IP address	192.168.0.7
Username	admin
Password	admin

**Figure 14 Web server default parameters**

After firstly connecting PC to CANET200, user can open browser and enter default IP 192.168.0.7 into address bar, then log in username and password, user will enter Web Server. Web Server screenshot as follow:

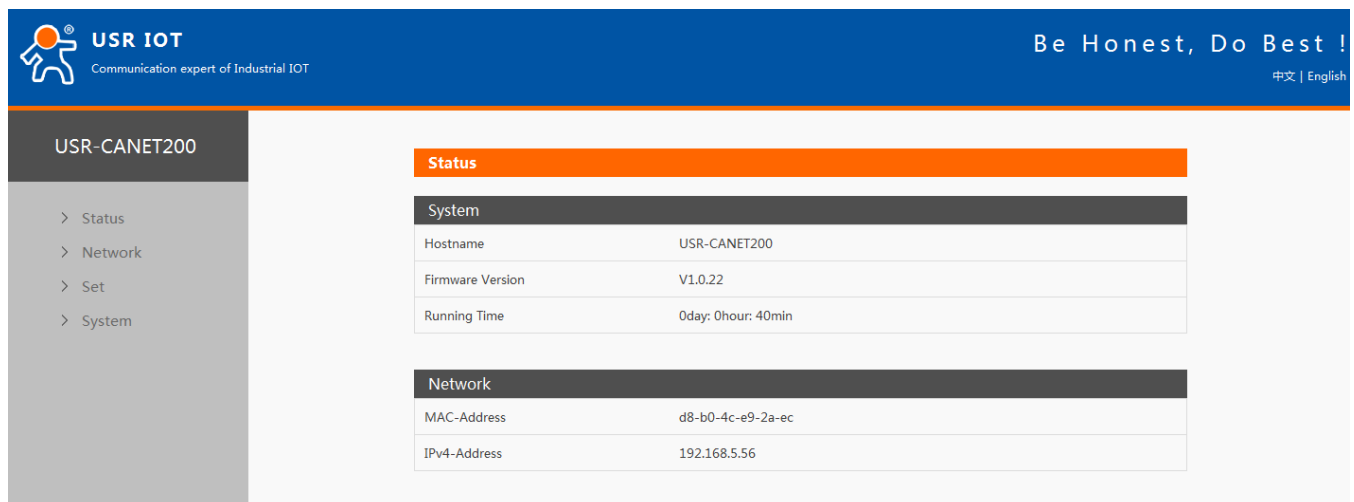

**Figure 15 Web Server**

User can switch between Chinese/English by clicking top right corner. If user changes Web page port, user should enter IP address with colon and port number(such as 192.168.0.7:90).

### 3.3.AT command

We have specific user manual for AT commands.

#### 3.3.1.Serial AT command mode

In work mode, user can enter AT command mode and send AT commands to module to configure the module. For

entering AT command mode, please refer to this FAQ: <http://www.usriot.com/enter-serial-command-mode/>.

### 3.3.2. Network AT command mode

Network AT command is to send a search keyword by UDP broadcast, then set the parameters in a single broadcast way (If user wants to use network AT command, module and PC which send the network AT command must in same network segment). Default keyword is **www.usr.cn** and default port number is 48899. If user enters network AT command mode but don't send any command over 30 seconds, module will exit network AT command mode. User can enter network AT command mode as follow way:

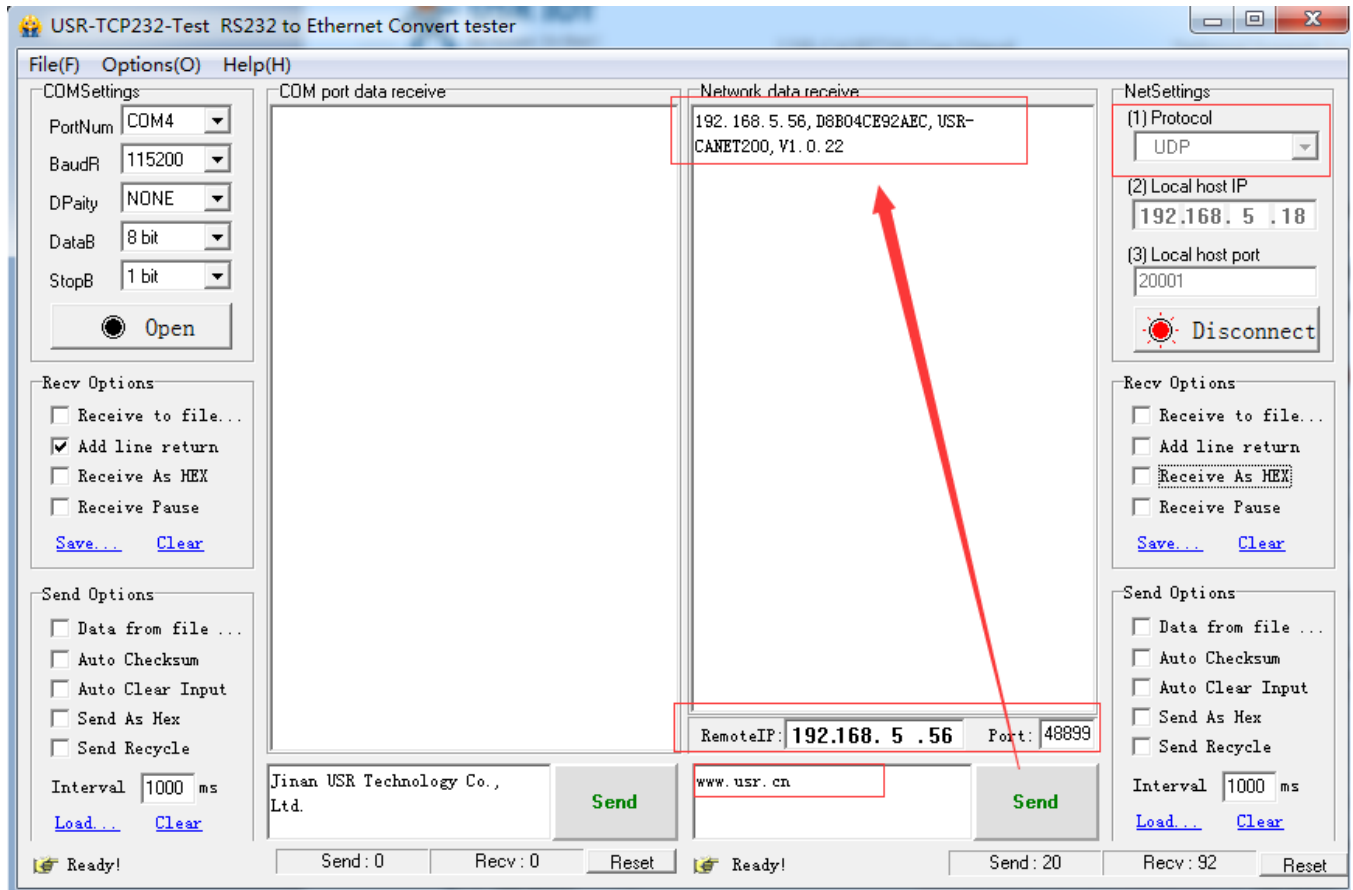

Figure 16 Network AT command mode

## 4. Contact Us

Company: Jinan USR IOT Technology Limited

Address: Floor 11, Building 1, No. 1166 Xinluo Street, Gaoxin District, Jinan, Shandong, 250101, China

Web: [www.usriot.com](http://www.usriot.com)

Support: [h.usriot.com](http://h.usriot.com)

Email: [sales@usr.cn](mailto:sales@usr.cn)

Tel: 86-531-88826739/86-531-55507297

## 5.Disclaimer

This document provides the information of USR-CANET200 products, it hasn't been granted any intellectual property license by forbidding speak or other ways either explicitly or implicitly. Except the duty declared in sales terms and conditions, we don't take any other responsibilities. We don't warrant the products sales and use explicitly or implicitly, including particular purpose merchant-ability and marketability, the tort liability of any other patent right, copyright, intellectual property right. We may modify specification and description at any time without prior notice.

## 6.Update History

2018-01-29 V1.0.4.01 established based on Chinese version V1.0.4.