

WP3078ADAM

User's Manual

Version 1.42A

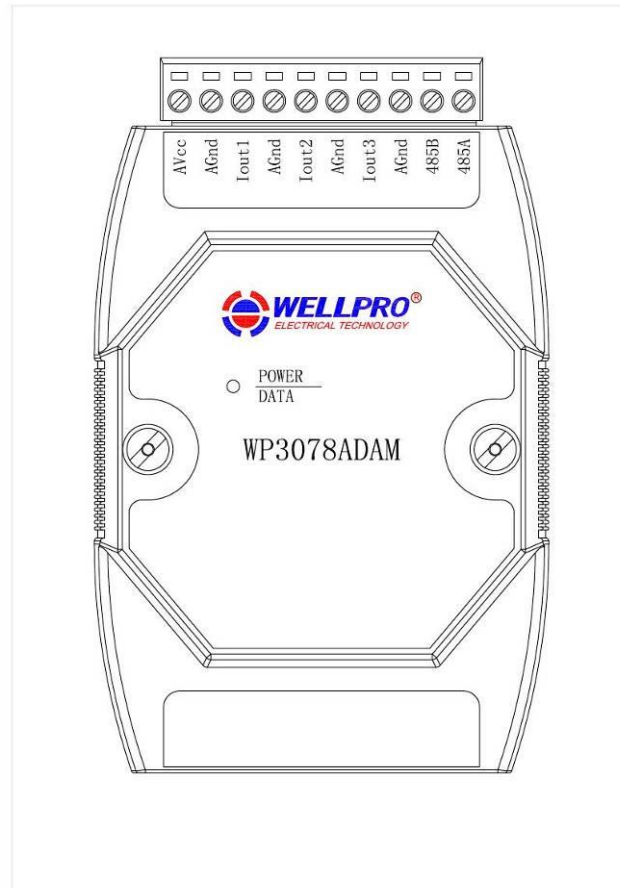

Shanghai Wellpro Electrical Technology Co., Ltd.
www.shwellpro.com

1、Product description

- Three current output channel: DC4~20mA
- RS485 MODBUS RTU standard communication protocol
- Netted with configuration software, PLC or industry touch panel
- Communication status LED
- Communication circuit designed for thunder protection and interference immunity
- Used for signal collection and control in industrial field

2、Specification

- Analog output channel 3ch
- Analog output range DC4~20mA
- Analog output accuracy $\pm 0.03\text{mA}$
- Maximum output load 1050Ω (DC24V)
- Working temperature $-20\sim 70^\circ\text{C}$
- External power supply DC9V~30V/2W
- Isolation protection DC1500V
- Installation method Standard DIN slide rail or screw
- Dimension $125\times 73\times 35\text{mm}$

3、Interface description

AVcc	External power supply input positive
AGnd	External power supply input negative / Power ground
Iout1	Current output channel 1 positive
AGnd	Current output channel 1 negative / Analog ground / Power ground
Iout2	Current output channel 2 positive
AGnd	Current output channel 2 negative / Analog ground / Power ground
Iout3	Current output channel 3 positive
AGnd	Current output channel 3 negative / Analog ground / Power ground
485B	RS485 signal B-
485A	RS485 signal A+

4、Analog output application diagram

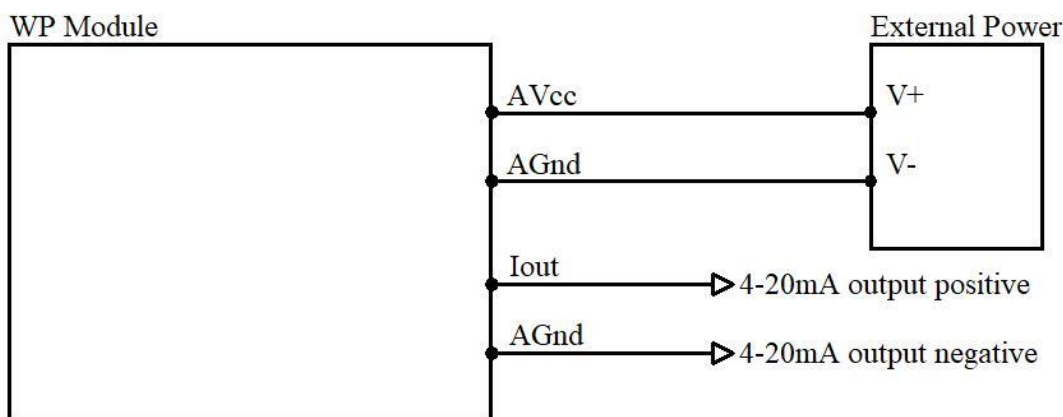

5、Communication description

5.1、Communication parameter: 9600, None, 8, 1 (default setting)

Parameter	Description
9600	baud rate
None	check bit
8	data bit
1	stop bit

5.2. Command for analog output data setting

Send: 01 06 00 00 2C 39 55 18 (example/hex)

data	byte	data description	remark
01	1	module address	address range:01-FE
06	1	function code	06-write single holding register
0000	2	register address (4X type)	0000-analog output channel 1 register 0001-analog output channel 2 register 0002-analog output channel 3 register
2C39	2	write data	current output data, range:0FA0-4E20
5518	2	CRC check code	CRC check code for all data

Receive: 01 06 00 00 2C 39 55 18 (example/hex)

This command sets module to output current.

The data of the analog output channel 1 is "2C39", it will be 11321 after converting to decimal data. Put it in the formula: $I_{out1} = DATA/1000 = 11321/1000 = 11.321mA$.

When module receives correct command, it will send response back to the master.

5.3. Command for analog output data reading

Send: 01 03 00 00 00 03 05 CB (example/hex)

data	byte	data description	remark
01	1	module address	address range:01-FE
03	1	function code	03-read holding register
0000	2	register address (4X type)	0000-starting register address
0003	2	register number	0003-read 3 registers
05CB	2	CRC check code	CRC check code for all data

Receive: 01 03 06 2C 39 1D 11 15 E7 A2 6F (example/hex)

data	byte	data description	remark
01	1	module address	address range:01-FE
03	1	function code	03-read holding register
06	1	byte of data	06-read 6 bytes
2C39 1D11 15E7	6	read data	2C39-analog output channel 1 data 1D11-analog output channel 2 data 15E7-analog output channel 3 data
A26F	2	CRC check code	CRC check code for all data

This command reads module's current output data.

The data of the analog output channel 1 is "2C39", it will be 11321 after converting to decimal data. Put it in the formula: $I_{out1} = DATA/1000 = 11321/1000 = 11.321mA$.

The data of the analog output channel 2 is "1D11", it will be 7441 after converting to decimal data. Put it in the formula: $I_{out2} = DATA/1000 = 7441/1000 = 7.441mA$.

The data of the analog output channel 3 is "15E7", it will be 5607 after converting to decimal data. Put it in the formula: $I_{out3} = DATA/1000 = 5607/1000 = 5.607mA$.

5.4. Command for module address setting

Send: 00 06 00 64 00 01 08 04 (example/hex)

date	byte	data description	remark
00	1	module address	00-broadcast address
06	1	function code	06-write single holding register
0064	2	register address (4X type)	0064-module address register
0001	2	write data	0001-new module address, range:0001-00FE
0804	2	CRC check code	CRC check code for all data

Receive: 00 06 00 64 00 01 08 04 (example/hex)

This command sets module address (slave address) as "01" (default setting). This setting could be saved when power off. This is a broadcast command. It needs to ensure that only one module is connected to the master.

When module receives correct command, it will send response back to the master.

5.5. Command for communication parameter setting

Send: 01 06 00 65 00 02 18 14 (example/hex)

data	byte	data description	remark
01	1	module address	address range:01-FE
06	1	function code	06-write single holding register
0065	2	register address (4X type)	0065-communication parameter register
0002	2	write data	0001- 4800, None, 8, 1 0002- 9600, None, 8, 1 0003- 19200, None, 8, 1 0004- 38400, None, 8, 1 0005- 4800, Even, 8, 1 0006- 9600, Even, 8, 1 0007- 19200, Even, 8, 1 0008- 38400, Even, 8, 1
1814	2	CRC check code	CRC check code for all data

Receive: 01 06 00 65 00 02 18 14 (example/hex)

This command sets communication parameter as “9600, None, 8, 1” (default setting). This setting could be saved when power off.

When module receives correct command, it will send response back to the master.

6. POWER/DATA LED description

- When module powered on, LED is green.
- When module is under communication, LED is twinkling.
- When module receives correct command, LED is green.
- When module receives incorrect command or other module’s command, LED is red.

7. PC debugging description

We provide a debugging software for function testing and parameter setting. Please follow the steps below:

- Connect computer to module with RS485 converter.
- Connect DC12V or DC24V power to module and power on. To avoid any unnecessary damage, please make sure the power positive and negative terminals are correctly connected before power on.
- Open the software and select the model of module, you will see the window of function testing or parameter setting.
- Set communication parameter and open the serial port.
- Select corresponding setting and click “Read” or “Write” button.

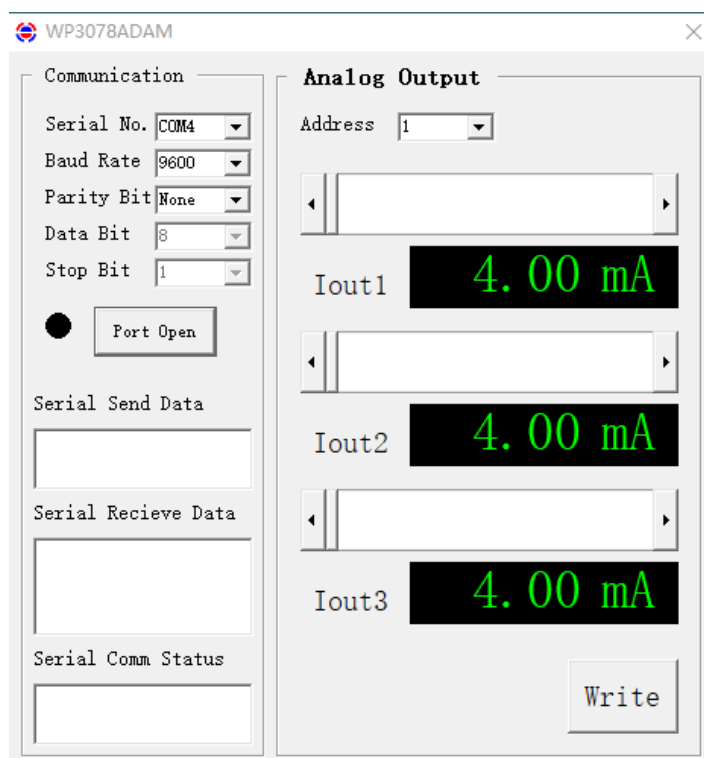

8、RS485 network diagram

