

Bottom View of Assembly

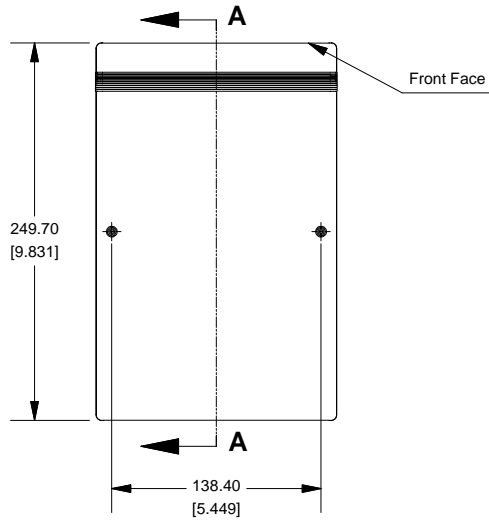

**SECTION A-A
(Side View Inside Assembly)**

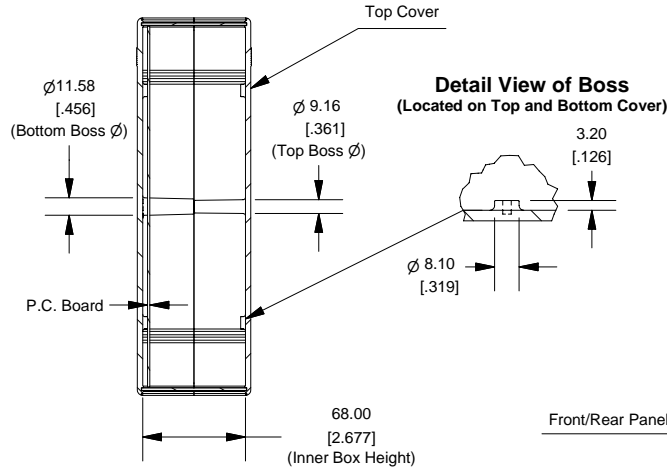

Instrument (1598G)

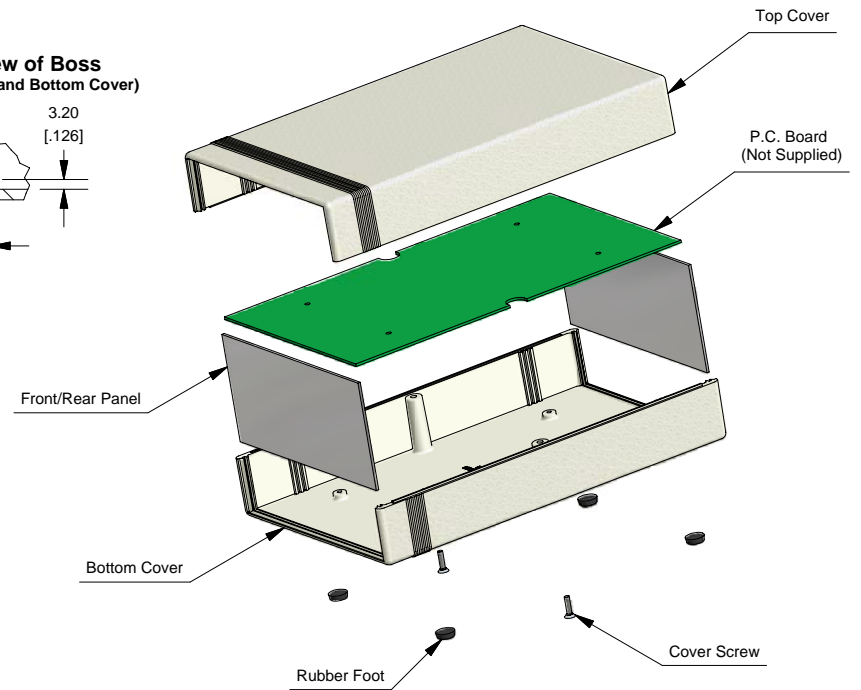

End View of Assembly

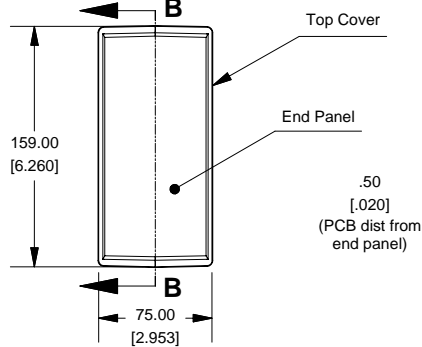

**SECTION B-B
(Inside of Bottom Cover)**

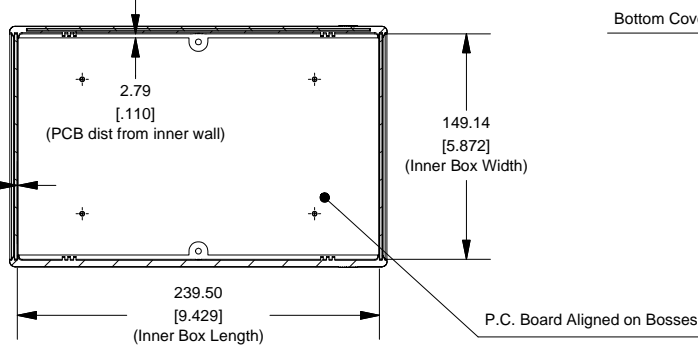

NOTE
Purchased assembly includes top and bottom cover, front and end aluminum panels (type 5005H32, SPV coating on one side), 2 cover screws, and 4 rubber feet.

PART NUMBERS		
1598G - Polystyrene (UL94-HB)		
Grey Enclosure with Aluminum Panels 1598GSGY	Grey Enclosure with Black Plastic Panels 1598GSGYPBK	Black EMI/RFI Shielded --
1598G - Flame Retardant ABS (UL94-VO)		
Black Enclosure with Aluminum Panels 1598GBK	Grey Enclosure with Aluminum Panels 1598GGY	Black EMI/RFI Shielded 1598RGBK
Accessories		
Black Plastic Panels (Optional) 1598PLGBK		Rubber Feet (Pkg 24) 1421T3
For 1598 Polystyrene Cover Screws (Pkg 100) [#4 x 5/8" (15.9mm)] 1598TS100	For 1598 FR-ABS Cover Screws (Pkg 100) [M3 - 0.5" x 10mm] 1591MS100	Both Models P.C. Board Screws (Pkg 100) [#6 x 1/4" (6.4mm)] 1598ATS100

**Front/Rear Panel
(Dashed Line Indicates Viewing Area)**

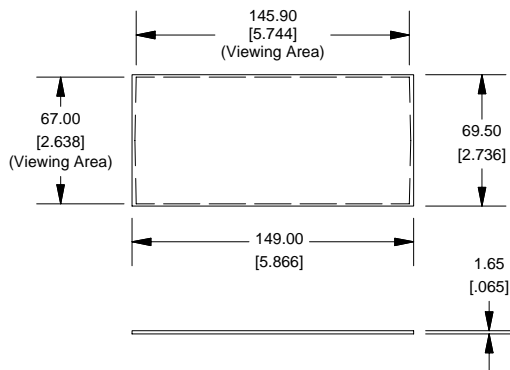

Maximum P.C. Board Size

