

12V DC LED STRIP LIGHTING DIMMER CONTROLLER

CEM-1006

This unit is designed for DIMMING 12V DC LED STRIP LIGHTS and up to 2 x 5 meter lengths of up to 10 Amps DC
5A

The supply must be able to handle at least 1.5 times the actual full load with all LEDs at full brightness. The unit can be operated from a car battery or from a regulated supply. MAXIMUM input Voltage not to EXCEED 12.5V DC. The unit is polarity protected.

The kit can be changed to users requirements. An assembly is given for a small plastic box of 70mm x 50mm x 23mm is shown.

The dimming potentiometer (pot) must be fixed to the pcb at terminals P1, P2 and P3.

The Pot is then soldered to these pins. If the dimming function is REVERSED there is a link on the pcb for correcting this, by removing it and connecting it in the other position.

The dimmer unit is designed for LEDs ONLY. Once the strip is in place, use RED and BLACK flex of 1mm sq back to the unit as the feed wire. (less voltage drop over the length)

The dimmer has a control range from 2% to about 98% (typical). This is the typical range of the controller unit. No provision has been made to switch the module off. At the minimum setting current is still been used. The POWER SUPPLY must be controlled to switch the unit on and off.

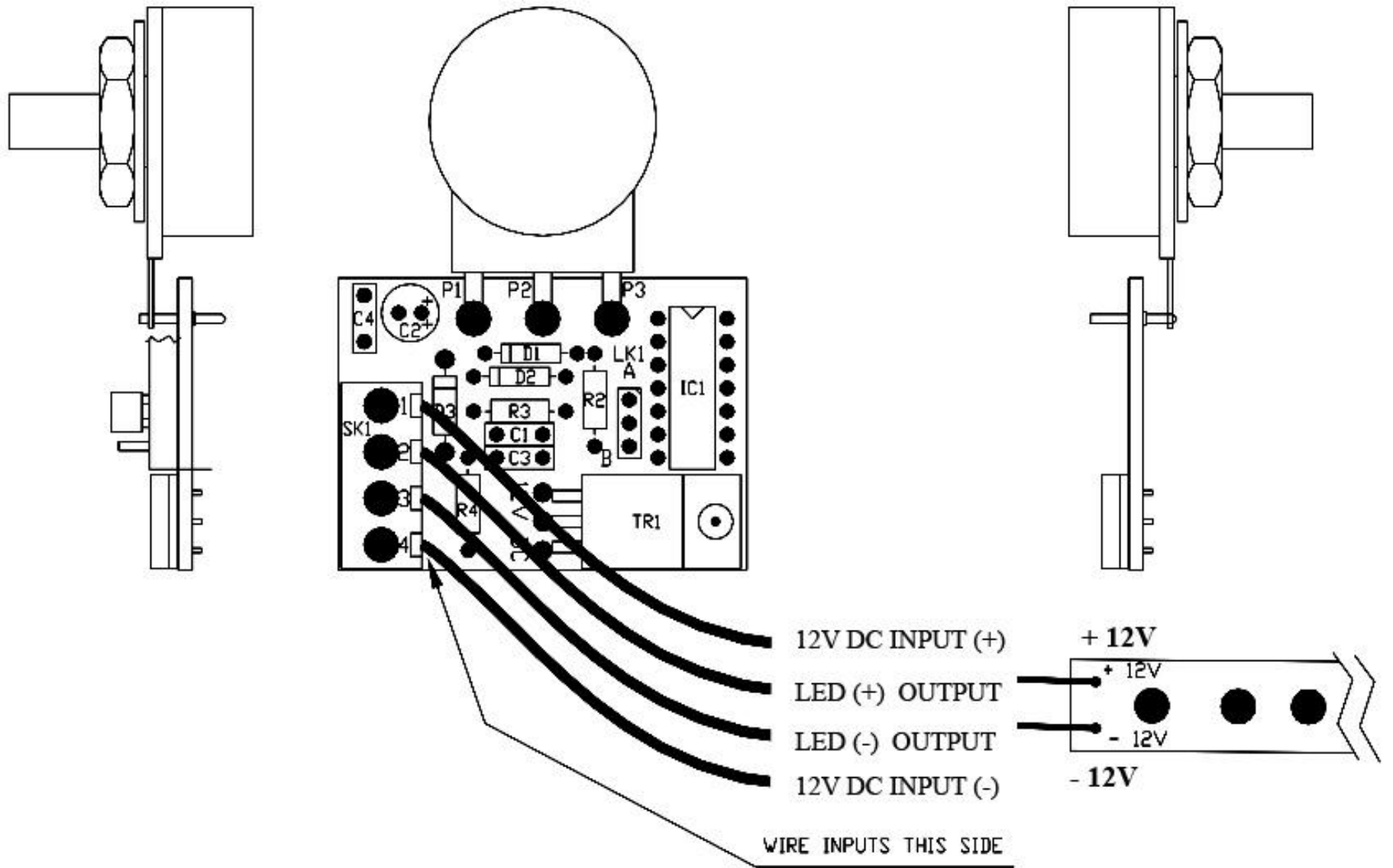

TYPICAL ASSEMBLY CONNECTIONS

REAR VIEW OF DIMMER IN PLASTIC BOX

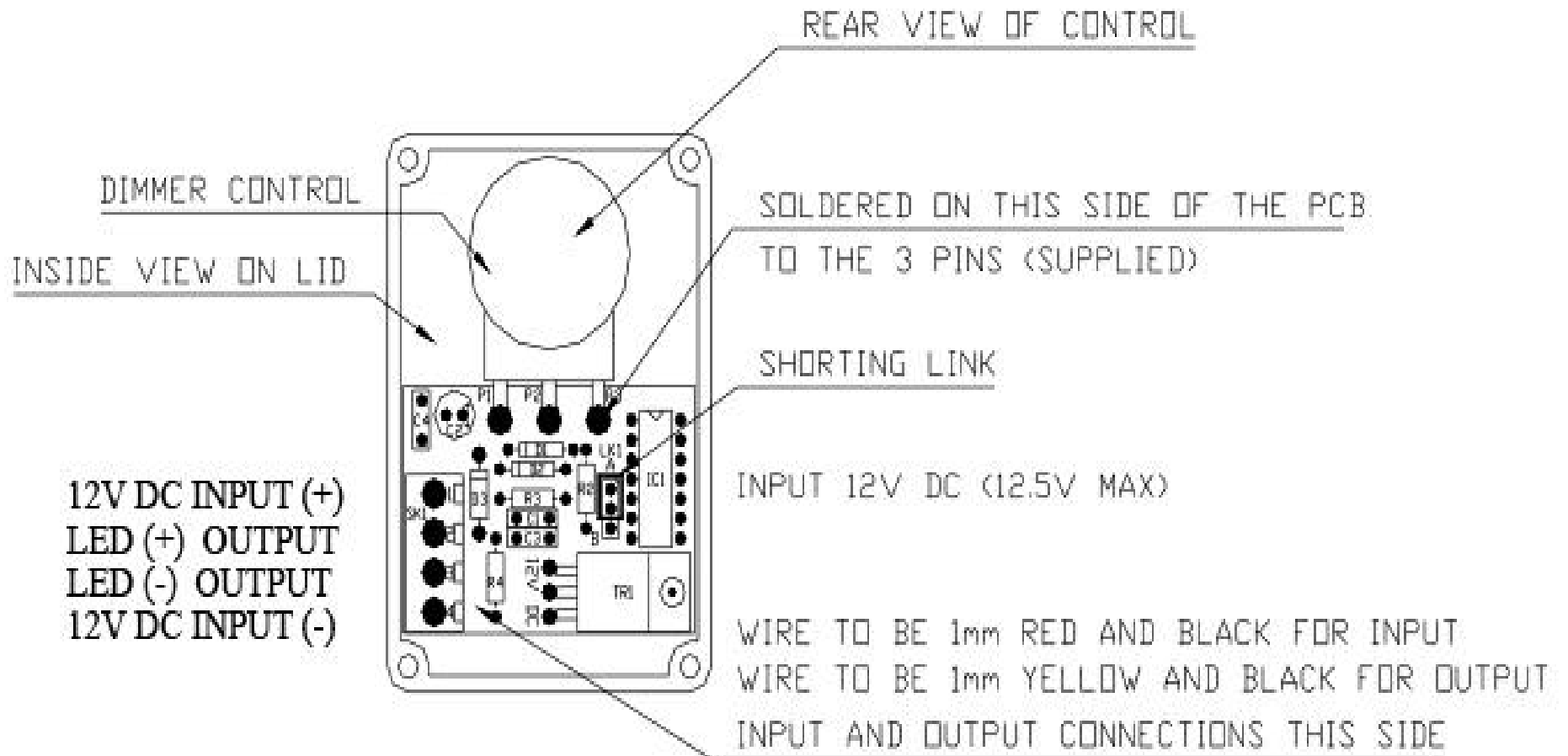

TYPICAL ASSEMBLY OPTION