

TOP VIEW

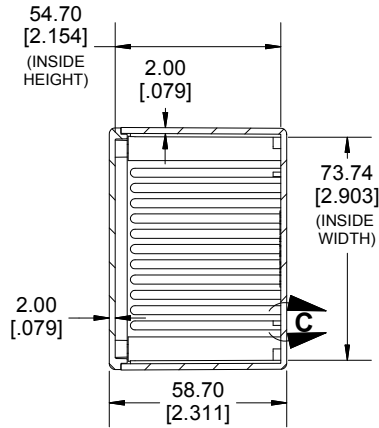

SECTION A-A

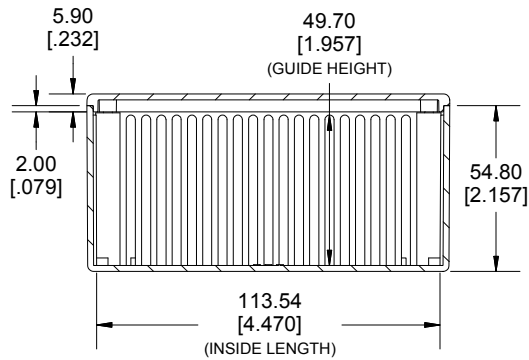
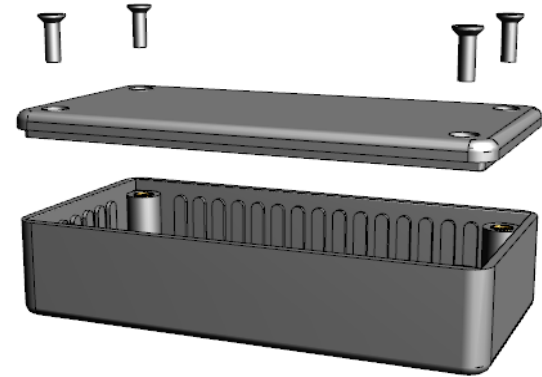

**SECTION B-B
SIDE VIEW**

DETAIL C

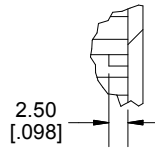

DETAIL D

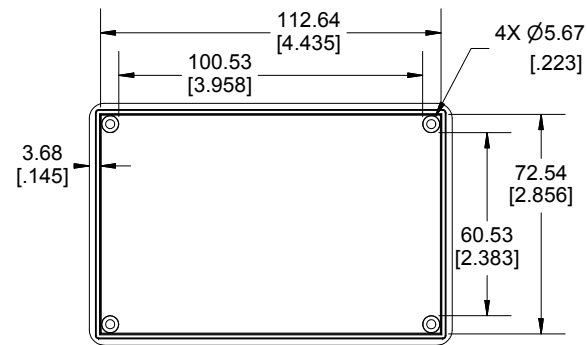
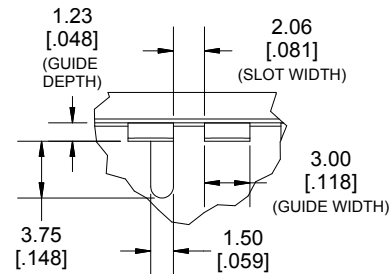

INSIDE LID

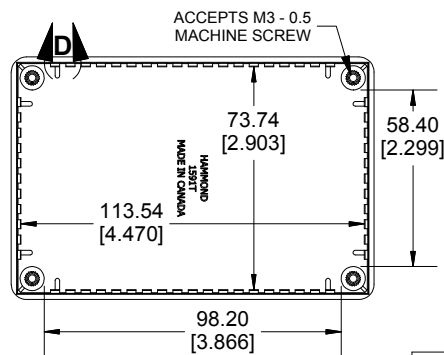

INSIDE BOX

Dimensions:
mm
[inches]

Enclosures can be Factory Modified (Milling, Drilling, Printing etc.)
Contact Factory mjm@hammondmfg.com for quotes
Solid models of this enclosure available in STEP or IGES.

NOTE	
Purchased assembly includes box, lid, 4 cover screws, and pre-installed brass inserts. Enclosure made from FRABS or Polycarbonate.	
Recommended Torque: 42-57 ozf.in (30-40 cN.m)	
PART NUMBERS	
1591T Enclosure	
Material	Colour Part Number
FR ABS UL94 -V0	Beige 1591TBG
	Black 1591TBK
	Blue 1591TBU
	Grey 1591TGY
Accessories	
Plated Cover screw M3 - 0.5 X 10mm (100Pkg)	1591MS100 (Silver) 1591MS100BK (Black)
PC Board Card Adapters	1591Z6 (6Pkg)
	1591Z50 (50 Pkg)
	1591Z100 (100Pkg)
Nylon Belt / Pocket clip	1599CLIP (Black)
	1599CLIPGY (Grey)
Clear Lids - Flame Retardant Polycarbonate - Lid ONLY	1591TC

**HAMMOND
MANUFACTURING®**

1591T

www.hammondmfg.com