

Bottom View of Assembly

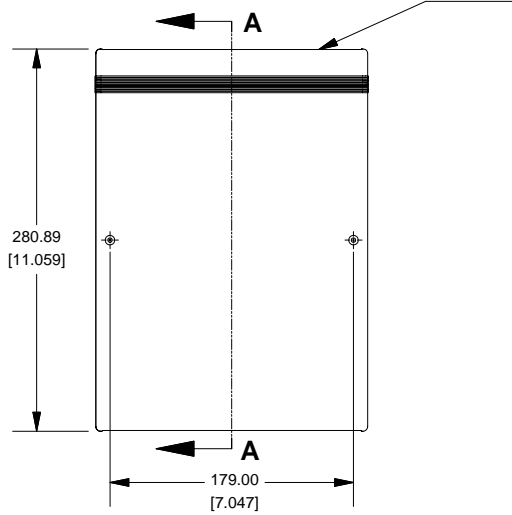

SECTION A-A (Side View Inside Assembly)

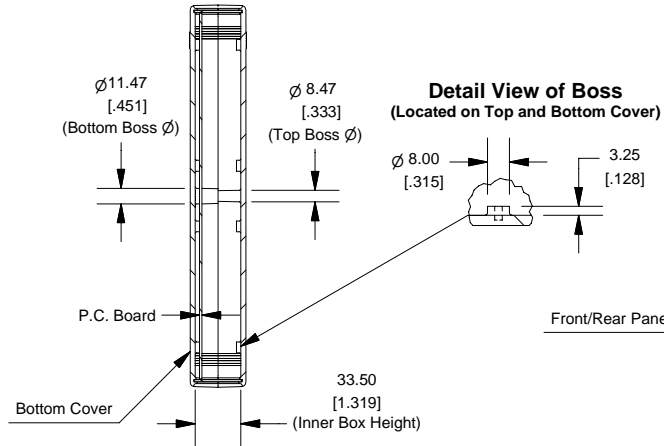

Instrument (1598H)

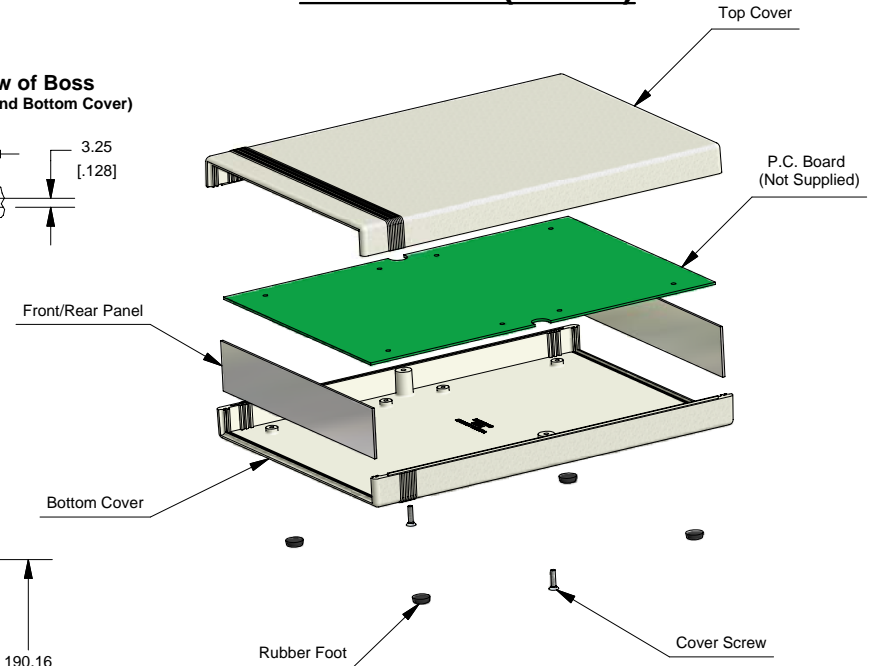

End View of Assembly

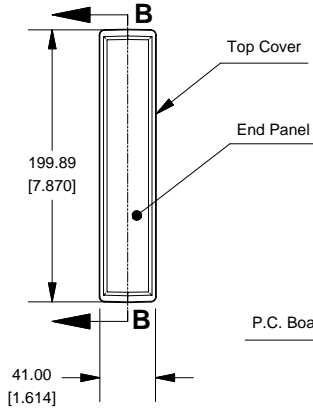

SECTION B-B (Inside of Bottom Cover)

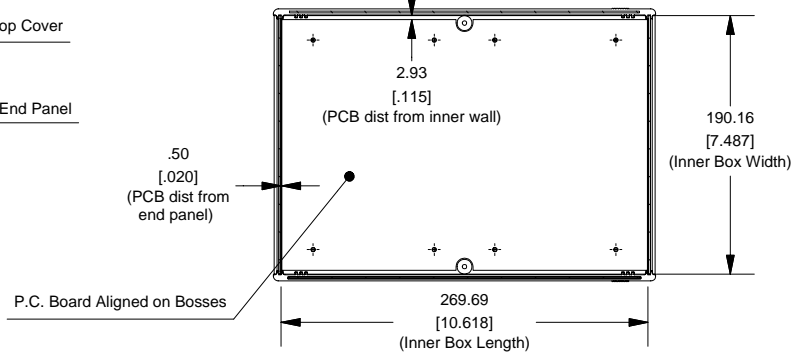

Front/Rear Panel (Dashed Line Indicates Viewing Area)

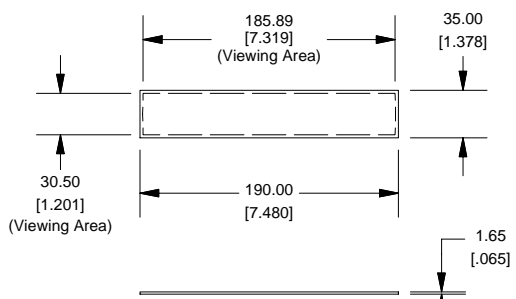

Maximum P.C. Board Size

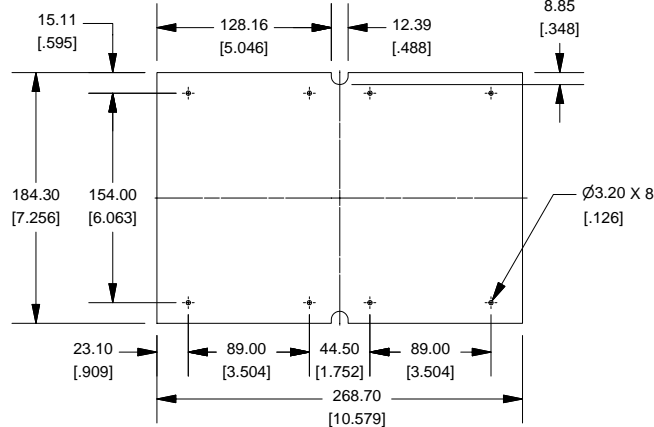

NOTE
Purchased assembly includes top and bottom cover, front and end aluminum panels (type 5005H32, SPV coating on one side), 2 cover screws, and 4 rubber feet.

PART NUMBERS		
1598H- Polystyrene (UL94-HB)		
Grey Enclosure with Aluminum Panels 1598HSGY	Grey Enclosure with Black Plastic Panels 1598HSGYPBK	Black EMI/RFI Shielded --
1598H - Flame Retardant ABS (UL94-VO)		
Black Enclosure with Aluminum Panels 1598HKBK	Grey Enclosure with Aluminum Panels 1598HGY	Black EMI/RFI Shielded 1598RHBK
Accessories		Rubber Feet (Pkg 24) 1421T3
Black Plastic Panels (Optional) 1598PLHBK		
For 1598 Polystyrene Cover Screws (Pkg 100) [#4 x 5/8" (15.9mm)] 1598TS100	For 1598 FR-ABS Cover Screws (Pkg 100) [M3 - 0.5" x 10mm] 1591MS100	Both Models P.C. Board Screws (Pkg 100) [#6 x 1/4" (6.4mm)] 1598ATS100

