



67 VERSAPAC INDUSTRIAL RELAY

- 2 to 8 Form C Contacts
- Direct PCB type, Panel / Socket Mountable Types
- Dust Protected / Sealed
- 3 to 7Amp Rating
- Power Adjusted and Sensitive Adjusted Versions
- Special Epoxy Sealed Version with Metal Enclosure
- Solder / Screw type Socket

SPECIFICATIONS

Contact Arrangement	
Power Adjusted Relays	: 2,4,6 & 8 Form C
Sensitive Adjusted Relay	: 2,4 & 6 Form C
Contact Material	
Standard	: Fine Silver with Gold overlay
Special	: Silver composite with Gold overlay
	: Bifurcated Contacts
Contact Rating	
Rated Voltage	: 230VAC / 24VDC
Max. Voltage	: 440 VAC / 220VDC
Max. Continuous Current	: See Contact Data
Life Expectancy	
Mechanical	: 10 ⁷ operations
Electrical	: 10 ⁶ operations 1A@28VDC/230VAC
	: 10 ⁵ operations for 3, 5, & 7A@230VAC/28VDC
Contact Resistance	: 50m Ohms Max (Initial)
Dielectric Strength	
Between Contacts & Coil	: 1000VRMS
Between Open Contacts	: 500VRMS
Insulation Resistance	: 500 Meg. Ohms at 500VDC, 25°C, RH50
Sensitivity in milli Watts	2C 4C 6C 8C
Power Adjusted	: 575 575 1000 1200
Sensitive Adjusted	: 160 245 380
Operate time (milli sec.)	
Power Adjusted	: 12 17 19 21
Sensitive Adjusted	: 24 28 33
Release time (milli sec.) (both power & sensitive)	: 8 11 11 11
Weight	: 30 35 40 45
Ambient Temperature	: -40°C to +70°C
Mounting	: Solder, Plug in, PC type

Typical applications

Railway Applications, Temperature Controllers, Timers, PLCs, Control Panel, Textile Machines etc.

All dimensions are in mm. Specifications subject to change without notice.

CONTACT RATING at 230VAC/24VDC

	Resistive	Inductive (L/R 8 m sec.)	Inductive (cosφ =0.7)
Power	3A	1.5A	1.5A
	5A	2.5A	5A* 3A
	7A	3.5A	5A*
Sensitive	3A	1.5A	1.5A

* For 50000 operations only

CIRCUIT DIAGRAMS

DC RELAYS

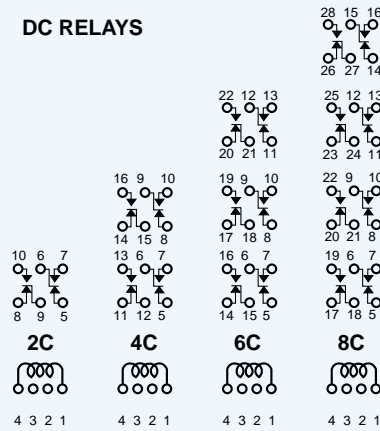

AC RELAYS

Dotted lines indicate external shortings

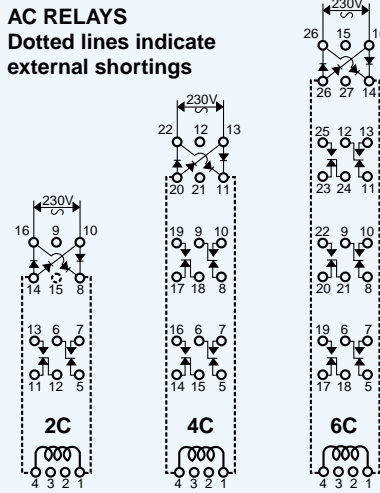

HOW TO ORDER

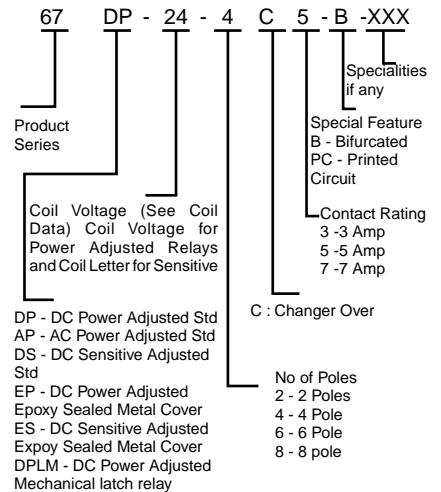

DIMENSIONS

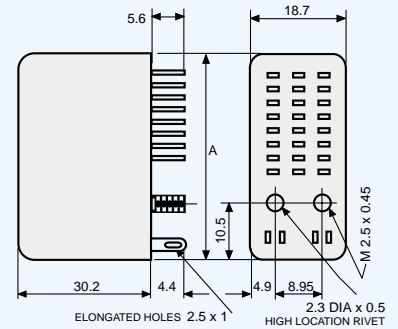

	A MAX (For DC relay)
2C	23.8
4C	29.5
6C	35.2
8C	40.5

	A MAX (For AC relay)
2C	29.5
4C	35.2
6C	40.5

DRILLING PATTERN

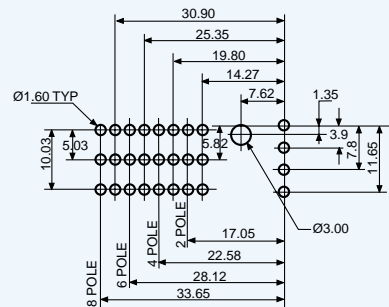

COIL DATA at 25°C AMBIENT

Coil Letter	Coil Resistance OHMS ± 10%	POWER ADJUSTED RELAYS 3,5 & 7A						SENSITIVE ADJUSTED RELAYS 3A					
		2 & 4 Form C		6 Form C		8 Form C		2 Form C		4 Form C		6 Form C	
		Nominal Voltage Volts	Pick-up Voltage Volts	Nominal Voltage Volts	Pick-up Voltage Volts	Nominal Voltage Volts	Pick-up Voltage Volts	Nominal Volts	Pick-up Max Current	Nominal Current mA	Pick-up Current Max mA	Nominal Current mA	Pick-up Current Max mA
AF	6	2	1.6	3	2.4	3.5	2.8	130.0	118.0	187	170	234	213
AK	14	3	2.4	4.5	3.6	4.8	3.8	85.4	77.6	123	112	154	140
W	16	3.5	2.8	4.8	3.8	5.0	4.0	79.9	72.6	114	104	144	131
C	20	4	3.2	5	4.0	6.0	4.8	71.5	65.0	102	93.3	129	117
B	25	5	4.0	6	4.8	8.0	6.4	63.8	58.0	92.9	83.5	115	105
A	52	6	4.8	8	6.4	10.0	8.0	44.2	40.2	63.4	57.6	80.7	73.4
F	72	7	5.6	10	8.0	12.0	9.6	37.4	34.0	53.9	49.0	67.6	61.5
E	90	8	6.4	12	9.6	14.0	11.2	34.1	31.0	48.3	43.9	59.9	54.5
X	130	10	8.0	14	11.2	16.0	12.8	28.1	25.5	40.3	36.6	50.5	45.8
D	185	12	9.6	16	12.8	18.0	14.4	23.5	21.4	33.8	30.7	42.2	38.4
Z	230	14	11.2	18	14.4	20.0	16.0	21.3	19.4	30.3	27.5	38.0	34.5
AA	280	16	12.8	20	16.0	22.0	17.6	19.1	17.4	27.4	24.9	34.3	31.2
J	350	18	14.4	22	17.6	24.0	19.2	17.1	15.5	24.5	22.3	30.7	27.9
H	430	20	16.0	24	18.0	28.0	22.4	15.4	14.0	22.1	20.1	27.7	25.2
AB	600	22	17.6	28	22.4	32.0	25.6	13.0	11.8	18.7	17.0	23.4	21.3
G	700	24	18.0	30	24.0	34.0	27.2	12.1	11.0	17.3	15.7	21.8	19.8
S	1000	30	24.0	40	32.0	42.0	33.6	10.2	9.4	15.1	13.8	18.7	16.9
M	1250	32	25.6	42	33.6	48.0	38.4	9.4	8.6	13.5	12.2	16.7	15.1
L	1550	36	28.8	48	38.4	52.0	41.6	8.5	7.8	12.2	11.0	15.2	13.8
AD	1800	40	32.0	52	41.6	55.0	44.0	8.0	7.2	11.3	10.2	14.4	13.0
K	2500	48	38.4	60	48.0	70.0	56.0	7.0	6.3	9.7	8.8	13.3	12.0
AG	2800	50	40.0	65	52.0	75.0	60.0	6.7	6.0	9.3	8.4	11.5	10.4
Y	3600	55	44.0	70	56.0	80.0	64.0	5.9	5.3	8.2	7.4	9.6	8.7
T	5000	65	52.0	85	68.0	95.0	76.0	5.1	4.6	7.1	6.4	8.7	7.9
AE	5800	70	56.0	90	72.0	100.0	80.0	4.8	4.3	6.7	6.0	8.3	7.5
AH	6000	75	60.0	95	76.0	102.0	81.6	4.7	4.2	6.4	5.8	8.1	7.3
R	8000	80	64.0	105	84.0	115.0	92.0	4.2	3.8	5.8	5.2	7.1	6.4
P	9000	85	68.0	115	92.0	125.0	100.0	4.0	3.6	5.4	4.9	6.7	6.0
V	10000	100	80.0	120	96.0	130.0	104.0	3.8	3.4	5.2	4.7	6.3	5.7
N	15000	115	92.0	140	112.0	165.0	132.0	3.5	3.1	4.0	3.6	5.3	4.8
AL	30000	230	184	-	-	-	-	-	-	-	-	-	-
AM	60000	250	200	-	-	-	-	-	-	-	-	-	-

MOUNTING HARDWARE & ACCESSORIES

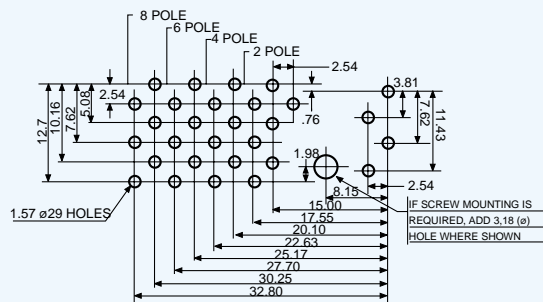
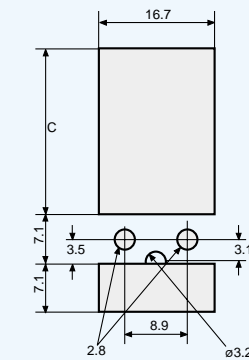
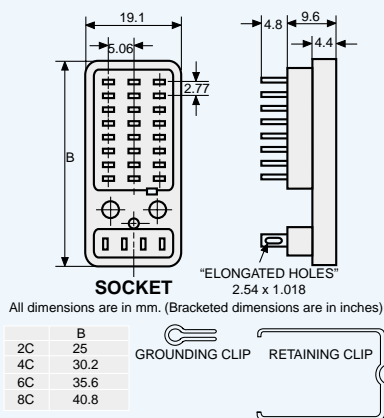

Dimensions tolerance ± 0.05 mm