

NOTES

MATERIAL: (ABS) FLAME RETARDANT UL94 V0 (FILE # E56070) MATERIAL WITH BRASS INSERTS IN CORNER POSTS. (STYRENE) IS NON-FLAME RETARDANT WITHOUT BRASS INSERTS.
 SCREWS: (ABS) MACHINE SCREWS M3-0.5 x 10mm. REPLACEMENT PN 1591MS100 (100/BAG). (STYRENE) SELF TAPPING #4 x 0.5". REPLACEMENT PN 1599TS100BK (100/BAG).
 COLORS: ** (ABS) BLACK, GRAY, BLUE, & BEIGE, (STYRENE) BLACK ONLY.
 STANDARD OPTIONS: SHIELDED, FLANGED BOTTOM, FLANGED LID

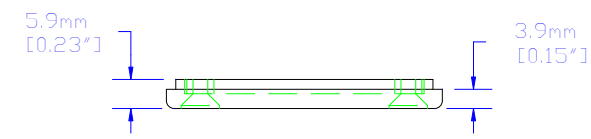
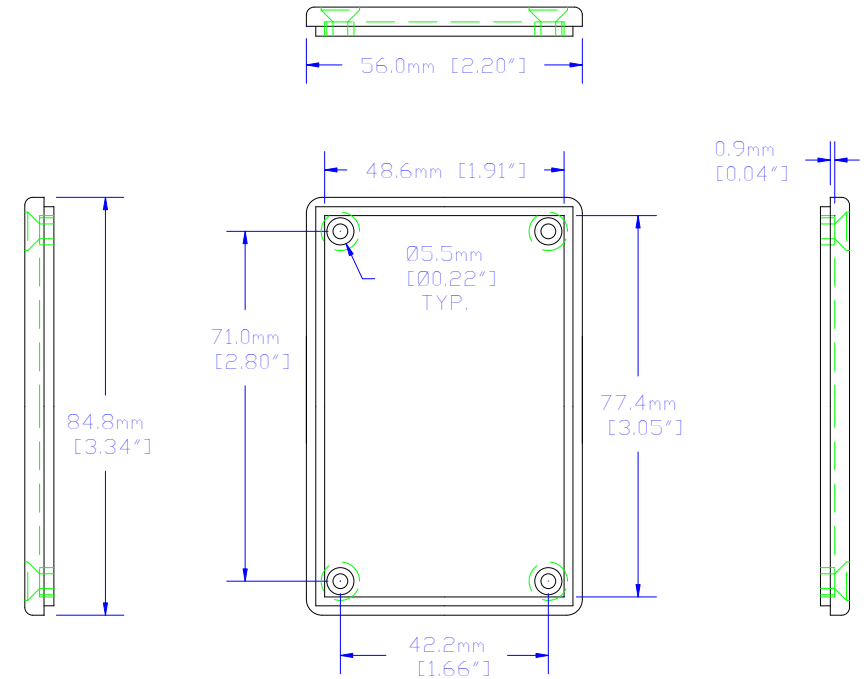
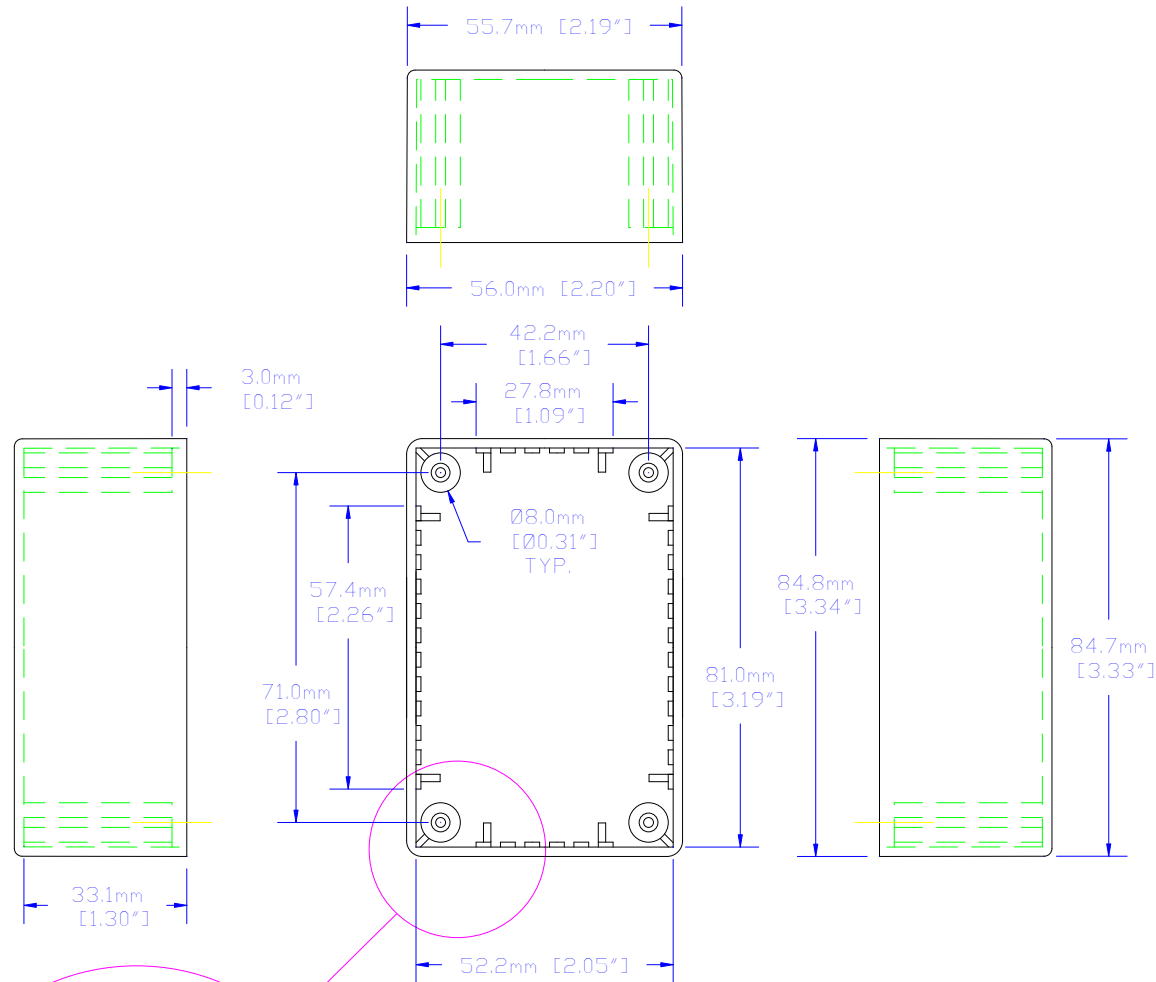

LID

CARD GUIDES ARE NOT DETAILED IN SIDE VIEWS

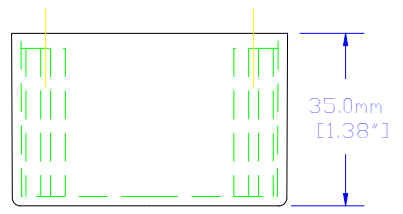
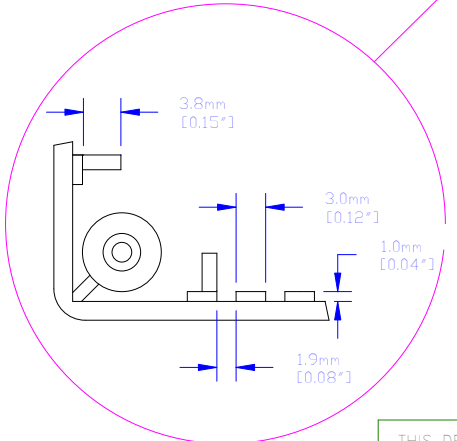

BOX

THIS DRAWING IS PROPRIETARY INFORMATION OF HAMMOND MFG.CO.LTD. NOT TO BE USED WITHOUT EXPRESSED WRITTEN PERMISSION OF HAMMOND MFG.CO.LTD.

△	N/A	RELEASE	----	12/27/02	MJM
Rev	ECN	Description		Date	B

Unless otherwise spec'd dimensions are in millimeters Tolerances are: .X ±0.5 .XX ±0.25 .XXX ±0.130 Holes ±0.130 Angles ±5°	Dwn	M. MERCER
	Date	12/27/02
	Chk	---
	Mat'l	SEE NOTES
Sheet	1 of 1	

HAMMOND MANUFACTURING CO. LTD. Electronics Group, Waterloo, Ont. - Cheektowaga, NY	HAMMOND 1591 SERIES PLASTIC ENCLOSURE	

For the best fit print on legal size paper.