

Kit 32. THREE STAGE FM TRANSMITTER

This Kit is a powerful three stage, 9V FM transmitter (Tx) with a range of up to 1 kilometer in the open. It uses an RF transistor in its output stage and two BC547's for the first two stages. Distance of transmission is critically dependent on the operating conditions (in a building or out on the open), type of aerial used (single wire or dipole), operating voltage (12V is better than 6V) and if the circuit is peaked for maximum performance.

The kit is constructed on a single-sided printed circuit board (PCB). It has a silk screen overlay on top to aid construction. On the bottom there is a solder mask to help in soldering. Protel Autotrax and Schematic were used to design the board.

ASSEMBLY INSTRUCTIONS

Components may be added to the PCB in any order. It is usually easier to add the lowest height components first then proceed to the taller components. The electret microphone should be inserted with the pin connected to the metal case connected to the negative rail (that is, to the ground or zero voltage side of the circuit.) This is marked with a '-' sign at the MIC on the circuit board printed overlay.

To save space all the resistors must be inserted standing up on one end. Be careful to get the transistors around the correct way. Note three points:

- the two 100n capacitors on the PCB have 0.2" and 0.1" spacing. We have put in components with the correct spacing for ease of construction.
- we have supplied prewound, pre-soldered enamel 6 turn & 8 turn wire coils. The legs should solder directly to the pads of the PCB. However, pay special attention to the solder joint in case all the enamel has not been removed. You may have to solder off or scrape off more enamel from the ends of the two enamelled coils.
- a connection (or tap) is required from the **middle** of the L1 tinned copper wire coil to the pad marked TAP next to the coil. Solder a piece of wire to the top of the middle turn as shown on the overlay. Then solder the other end to the pad immediately next to the L1 coil. Spread out the coils of L1 about 1 mm or more apart. Make sure none of the loops of the coil are touching the loop next to it.

CIRCUIT DESCRIPTION

The circuit is basically a radio frequency (RF) oscillator that operates around 100 MHz. Audio picked up and amplified by the electret microphone is fed into the audio amplifier stage built around the first transistor. Output from the collector is fed into the base of the second transistor where it modulates the resonant frequency of the tank circuit (L1 coil and the red trimcap) by varying the junction capacitance of the transistor. Junction capacitance is a function of the potential difference applied to the base of the transistor T2. The tank circuit is connected in a Hartley oscillator circuit. The final stage

built around T3 amplifies the output RF signal. Let us look at the individual blocks of the circuit more closely:

The electret microphone: an electret is a permanently charged dielectric. It is made by heating a ceramic material, placing it in a magnetic field and then allowing it to cool while still in the magnetic field. It is the electrostatic equivalent of a permanent magnet. In the electret microphone a slice of this material is used as part of the dielectric of a capacitor in which the diaphragm of the microphone forms one plate. Sound pressure moves one of its plates. The movement of the plate changes the capacitance. The electret capacitor is connected to an FET amplifier. These microphones are small, have excellent sensitivity, a wide frequency response and a very low cost.

First amplification stage: this is a standard self-biasing common emitter amplifier. The 22nF capacitor isolates the microphone from the base voltage of the transistor and only allows alternating current signals to pass.

Oscillator stage: every transmitter needs an oscillator to generate the RF carrier waves. The tank circuit, the transistor and the feedback capacitor are the oscillator circuit here. An input signal is not needed to sustain the oscillation. The feedback signal makes the base-emitter current of the transistor vary at the resonant frequency. This causes the emitter-collector current to vary at the same frequency. This signal fed to the aerial and radiated as radio waves.

The name 'tank' circuit comes from the ability of the LC circuit to store energy for oscillations. In a pure LC circuit (one with no resistance) energy cannot be lost. (In an AC network only the resistive elements will dissipate electrical energy. The purely reactive elements, the C and the L, just store energy to be returned to the system later.) Note that the tank circuit does not oscillate just by having a DC potential put across it. Positive feedback must be provided.

Trim Cap. The slots inside the trim cap are shaped like the head of an arrow. The maximum capacitance value is when the arrow is in pointed to the 12 o'clock position. A 180° turn brings the trimcap value to its minimum rated value. With experimentation you will be able to build up a table of total capacitance value (remember to add in the 10pF) to FM frequency. You can also change the frequency by altering the space between the coils of L1. **Spread out the L1 coil wide apart.**

The 10pF ceramic capacitor in parallel with the red trim cap will enable you to tune the Tx in the 98 MHz to 105 MHz range of the commercial FM band. If you use a higher value (for example, 27pF) you will move the frequency down towards the other end of the FM band. This end generally has more commercial stations in it. **Final Amplification Stage:** this RF stage adds amplification to the RF signal. It needs an RF transistor to do this efficiently. We use a Zetex ZTX320. L2 (an RFC -

Kit 32. THREE STAGE FM TRANSMITTER

radio frequency choke) and the 10pF capacitor in parallel with it are designed to reduce harmonics from the circuit. Output power from this stage will be maximum when it is tuned to oscillate at the same frequency as the previous stage. This can be done with the **peaking circuit** provided and described separately below.

A small (10pF) coupling capacitor on the aerial is optional to minimise the effect of the aerial capacitance on the final stage LC circuit. (We have not used one in this circuit.)

Dipole Antenna. Greater range from the transmitter can be obtained by replacing the half-wave antenna (the length of wire about 160cm long) with a dipole antenna. This is basically two wires attached to two points in the circuit which are oscillating 180° out of phase with each other. Two such points are the antenna point and the positive rail (the +9V track.) You can experiment by cutting the antenna wire in half, leaving half soldered into the antenna point and soldering the other half to the +9V pad. Point the two wires in opposite directions.

Operating Voltage. Output power is also increased by using a higher operating voltage. 9V is better than 6V. The maximum operating voltage for this Kit is determined by the ZTX320. This is 15V but if you try this then the values of some resistances will have to change. You can experiment with this.

WHAT TO DO IF IT DOES NOT WORK

Poor soldering is the most likely reason that the circuit does not work. Check all solder joints carefully under a good light. Next check that all components are in their correct position on the PCB. Did you add the connection from the middle of coil L1 to the pad marked TAP? Check that the leads of the two coils L2 and L3 are not dry joints. Use a multimeter to check this. Check that you have not accidentally formed a solder connection between

two pads which are next to each other. Did you turn the switch 'on'. Check that you did not interchange the 4K7 with the 47K resistors. Is the ZTX320 around the correct way and in the T3 position. Have you really **spread out** the coils of L1? Some people have told us that each end of L1 should be bent over and just about touching the PCB. They also said that L3 should be spread apart a little.

See us at <http://kitsrus.com>

COMPONENTS

Resistors, 5%, 1/4W:

100R brown black brown	1
470R yellow violet brown	1
4K7 yellow violet red	1
22K red red orange	1
39K orange white orange	1
47K yellow violet orange	2
1M brown black green	1

Capacitors:

Trim cap 5-20pF, red	1
5.6 pF ceramic	1
10p ceramic	2
47pF ceramic	3
1nF ceramic	1
20nF or 22nF ceramic	2
100nF monoblock	2
RF transistor ZTX320	1
Small signal transistor BC547	2
6 turn tinned copper coil	1
6 turn enamelled coil	1
8 turn enamelled coil	1
9V battery snap	1
Electret microphone	1
PCB-mounted SPDT switch	1
Antenna wire	1.6m
k32 PCB	1
Peaking circuit	1 packet of components

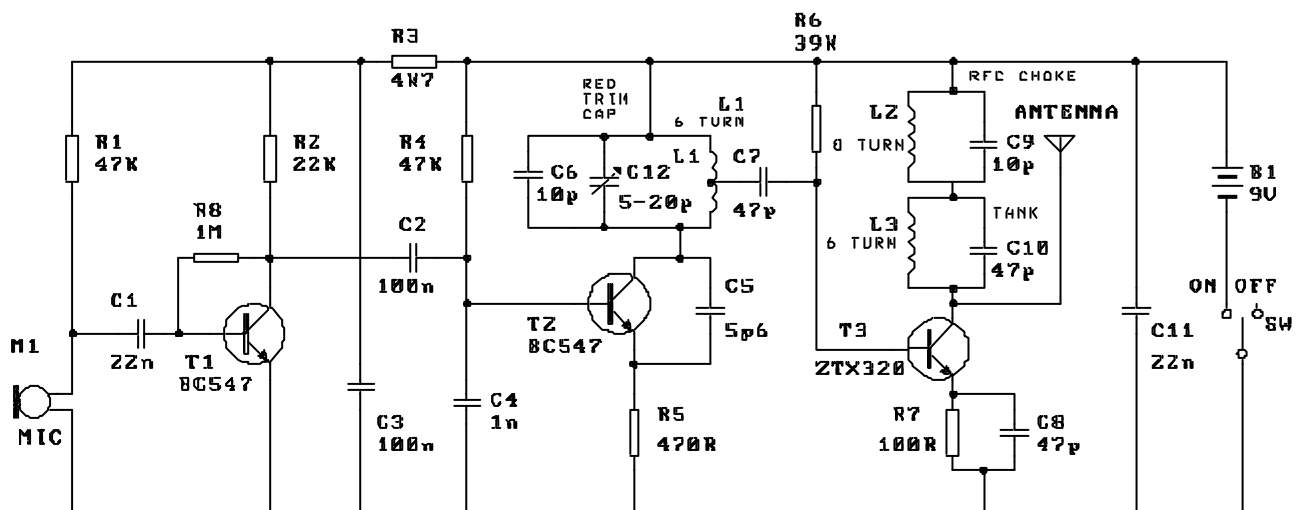

Kit 32. THREE STAGE FM TRANSMITTER

Peaking Circuit. Kit 32.

The tank circuit - coil L3 and the 47pF capacitor - needs to be tuned in order to get maximum power output. It has to be tuned to match the frequency of the oscillator stage - 10pF cap, variable capacitor and tapped L1 coil. The output “peaks” as the tank circuit is tuned to match the oscillator frequency. This peak can be measured on a multimeter.

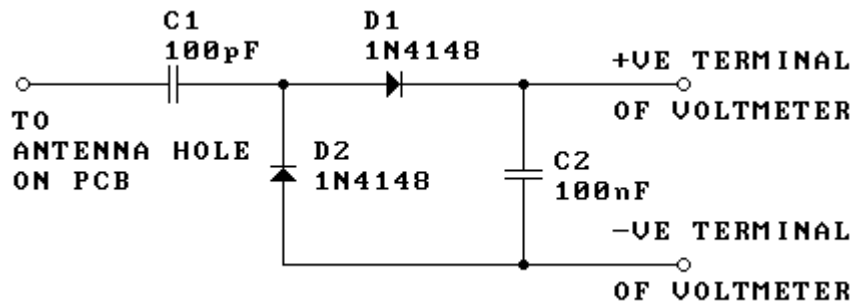

A peaking circuit (shown below) is simply an RF detector that uses diodes to charge a capacitor. The voltage across the capacitor is measured using a voltmeter set to a low voltage range (2 or 20V). The circuit can be assembled without the need of a PCB. Solder the components directly to each other. The output (across C2) should be connected directly to the voltmeter input using banana plugs or a pair of paper clips bent to shape. The input to the peaking circuit is soldered to the antenna wire hole on the PCB, using a 5cm (2”) length of wire. Switch the voltmeter to the 2V or 20V DC range.

To tune the tank circuit, move the turns of the tank coil **L3** further apart or closer together until the reading on the voltmeter is a maximum. Note that the reading will be lower while you are touching the coil. You will almost certainly find that the coil turns have to be spread very far apart with the last turn at each end of the coil almost touching the PCB. Once the output is a maximum, remove the peaking circuit and connect the antenna. If you change the oscillator frequency by moving the trimcap then you will need to repeat the peaking procedure to get maximum power output.

Want More Range?

You can get more range as a trade off against stability by:

- reduce R5 to 100R
- reduce R7 to 47R
- increase C7 to 470p

For a review of Kit 32 and many other FM transmitter kits on today's market see:

<http://members.tripod.com/~transmitters/begin.htm>

For the best list of links dealing with FM Transmitters see:

<http://members.tripod.com/~transmitters/> and press 'Everything you ever wanted to know about FM Transmitters'.

For a review of the theory behind two and three stage FM transmitter circuits download

<http://kitsrus.com/zip/fmtx.zip>

from my website. It is 1.1MB but has the full theory of operation behind these circuits.