

### Bottom View of Assembly

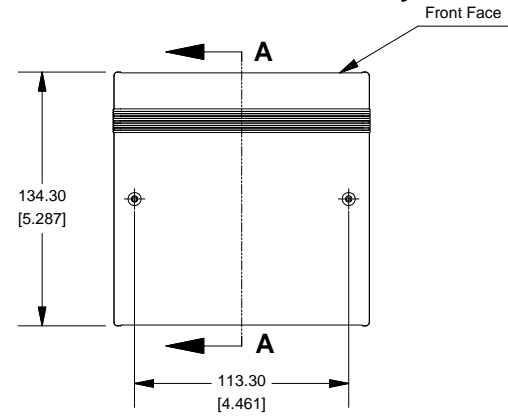

### SECTION A-A (Side View Inside Assembly)

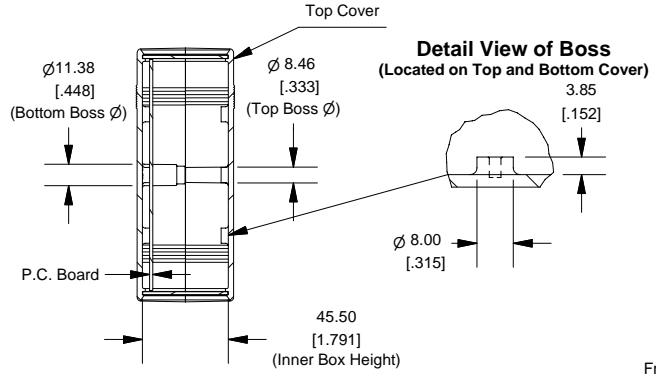

### End View of Assembly

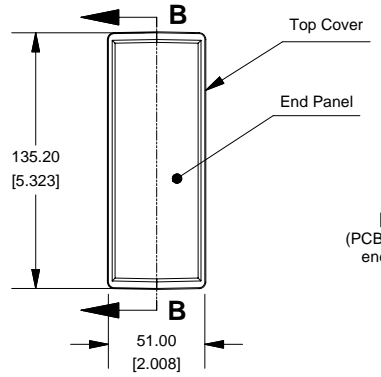

### SECTION B-B (Inside of Bottom Cover)

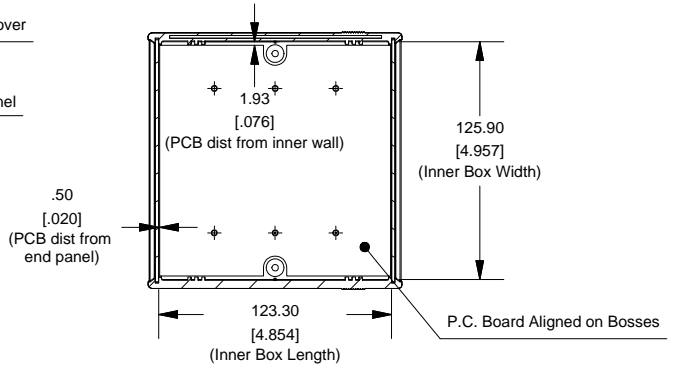

### Front/Rear Panel (Dashed Line Indicates Viewing Area)

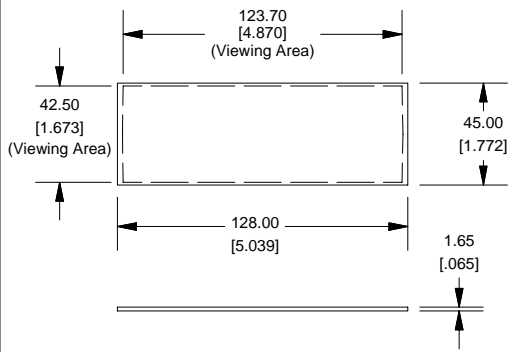

### Maximum P.C. Board Size

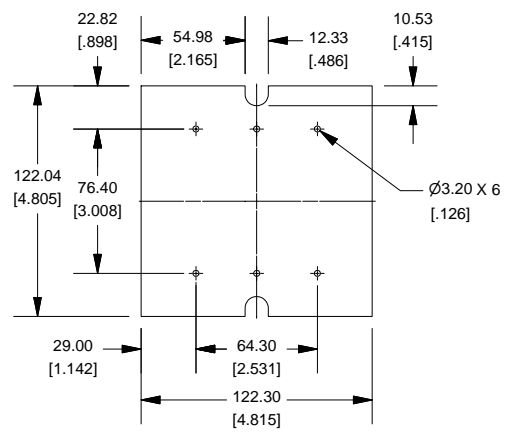

## Instrument Case (1598B)

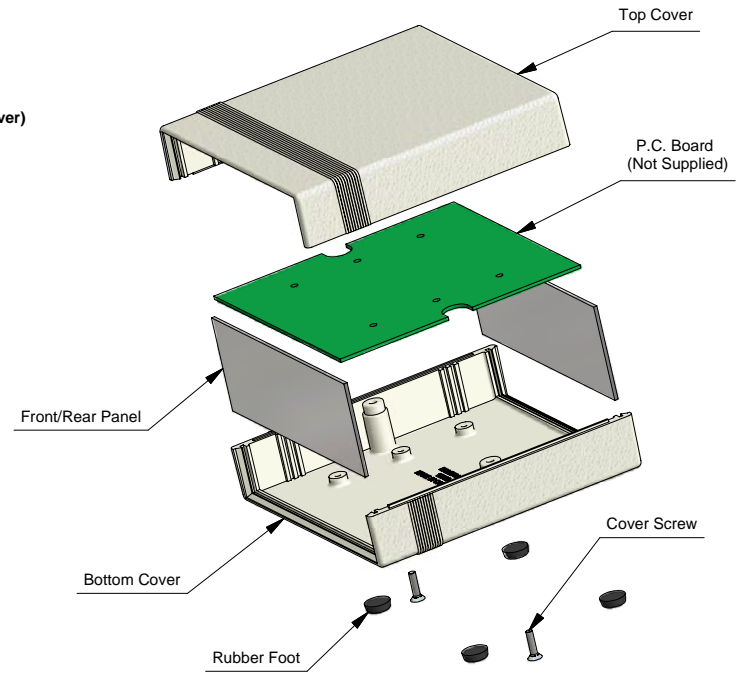

**NOTE**  
Purchased assembly includes top and bottom cover, front and end aluminum panels (type 5005H32, SPV coating on one side), 2 cover screws, and 4 rubber feet.

PART NUMBERS		
1598B - Polystyrene (UL94-HB)		
Grey Enclosure with Aluminum Panels	Grey Enclosure with Black Plastic Panels	Black EMI/RFI Shielded
1598BSGY	1598BSGYPBK	--
1598B - Flame Retardent ABS (UL94-V0)		
Black Enclosure with Aluminum Panels	Grey Enclosure with Aluminum Panels	Black EMI/RFI Shielded
1598BBK	1598BGY	1598RBBK
Accessories		
Black Plastic Panels (Optional)		Rubber Feet (Pkg 24)
1598PLBBK		1421T3
For 1598 Polystyrene Cover Screws (Pkg 100) [#4 x 5/8" (15.9mm)]	For 1598 FR-ABS Cover Screws (Pkg 100) [M3 - 0.5" x 10mm]	Both Models P.C. Board Screws (Pkg 100) [#6 x 1/4" (6.4mm)]
1598TS100	1591MS100	1598ATS100

