

# JZC-42F

## SUBMINIATURE INTERMEDIATE POWER RELAY



File No.:E133481



File No.:R2034199



File No.:CH0049032-2000



### Features

- 5A switching capabilities
- 2 Form A slim type
- Sealed and Unsealed type available

### CONTACT DATA

Contact Arrangement	2A
Initial Contact Resistance Max.	100mΩ (at 1A 6VDC)
Contact Material	AgCdO, AgSnO
Contact Rating (Res. Load)	5A/250VAC 5A/30VDC
Max. switching voltage	250VAC/30VDC
Max. switching current	5A
Max. switching power	1250VA /150W
UL/CUR rating	TV-3 5A 250VAC
TÜV rating	5A 30VDC
Mechanical life	1 x 10 <sup>6</sup> OPS
Electrical life	1 x 10 <sup>5</sup> OPS

### COIL

Coil power	0.53W
------------	-------

### COIL DATA

Nominal Voltage VDC	Pick-up Voltage VDC	Drop-out Voltage VDC	Max. allowable Voltage VDC(at 20°C)	Coil Resistance Ω
5	3.75	0.25	6.5	47 ± 10%
6	4.50	0.30	7.8	68 ± 10%
9	6.75	0.45	11.7	155 ± 10%
12	9.00	0.60	15.6	270 ± 10%
18	13.5	0.90	23.4	620 ± 10%
24	18.0	1.20	31.2	1080 ± 10%
48	36.0	2.40	62.4	4400 ± 10%

### CHARACTERISTICS

Initial Insulation Resistance	1000MΩ 500VDC	
Dielectric Strength	Between coil and Contacts	4000VAC 1min.
	Between open contacts	1000VAC 1min.
	Between contact sets	1000VAC 1min.
Operate time (at nomi. Volt.)	15ms	
Release time (at nomi. Volt.)	10ms	
Temperature rise (at nomi. Volt.)	Max. 55°C	
Humidity	5 to +85%RH	
Ambient temperature	-40°C to +70°C	
Shock Resistance	Functional	100 m/s <sup>2</sup>
	Destructive	1000 m/s <sup>2</sup>
Vibration Resistance	10 to 55Hz	
Termination	PCB	
Unit weight	Approx. 14.5g	
Construction	Sealed & Unsealed	



HONGFA RELAY  
ISO9001/QS9000/ISO14000 CERTIFIED

## ORDERING INFORMATION

Type	JZC-42F /	012	2H	S	T
Coil voltage 5, 6, 9, 12, 18, 24, 48VDC					
Contact arrangement 2H:2 Form A					
Structure Nil: Unsealed S: Sealed					
Contact Material T: AgSnO Nil: AgCdO					

## OUTLINE DIMENSIONS, WIRING DIAGRAM AND PC BOARD LAYOUT

### Outline Dimensions

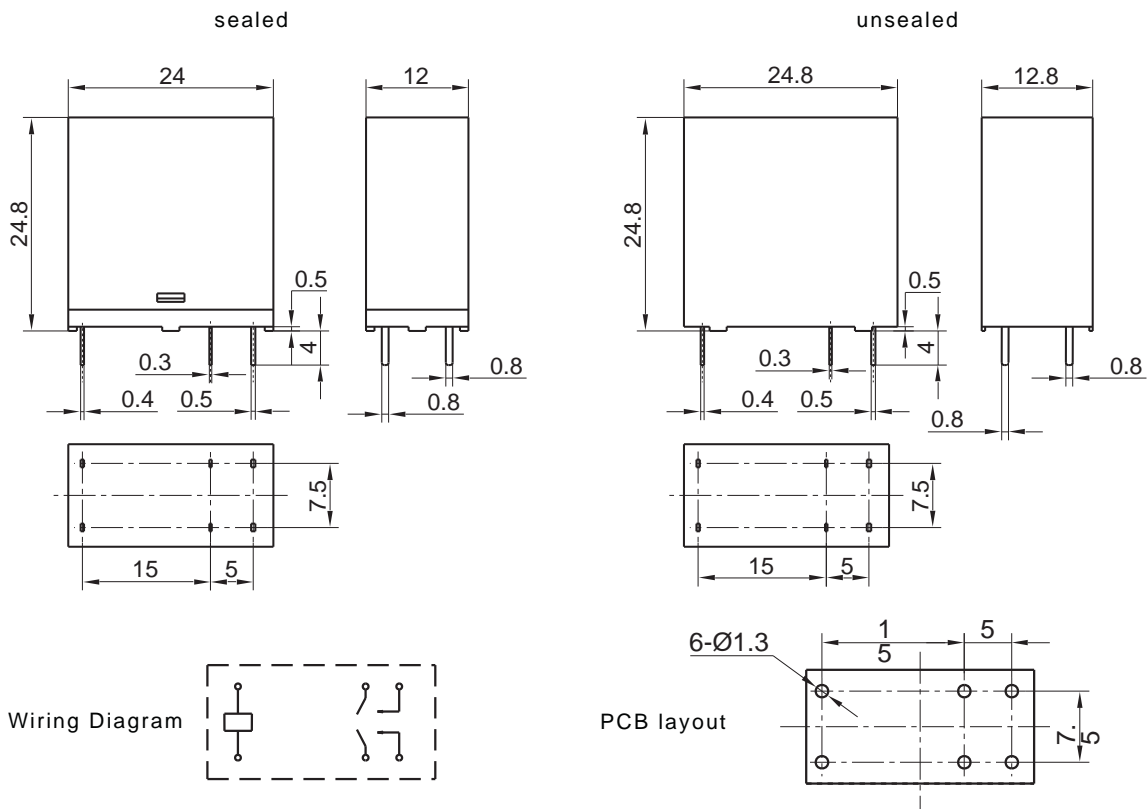

## CHARACTERISTICS CURVE

