

Top View of Assembly

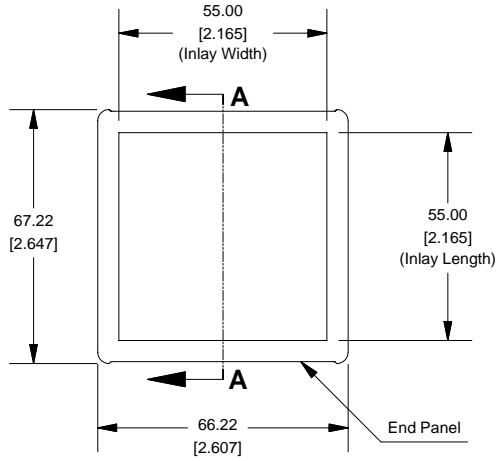

SECTION A-A (Side View Inside Assembly)

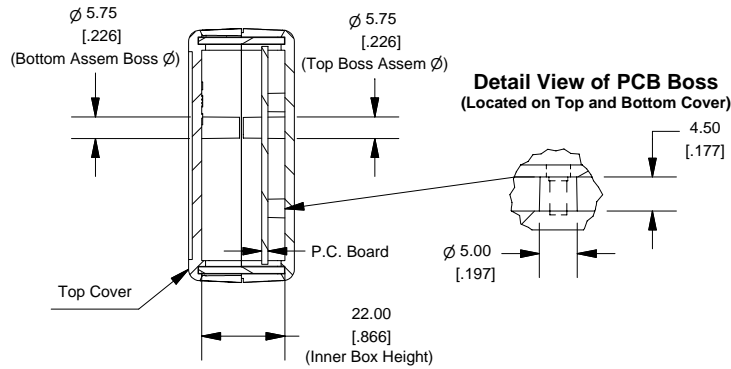

Hand Held Instrument (1593K)

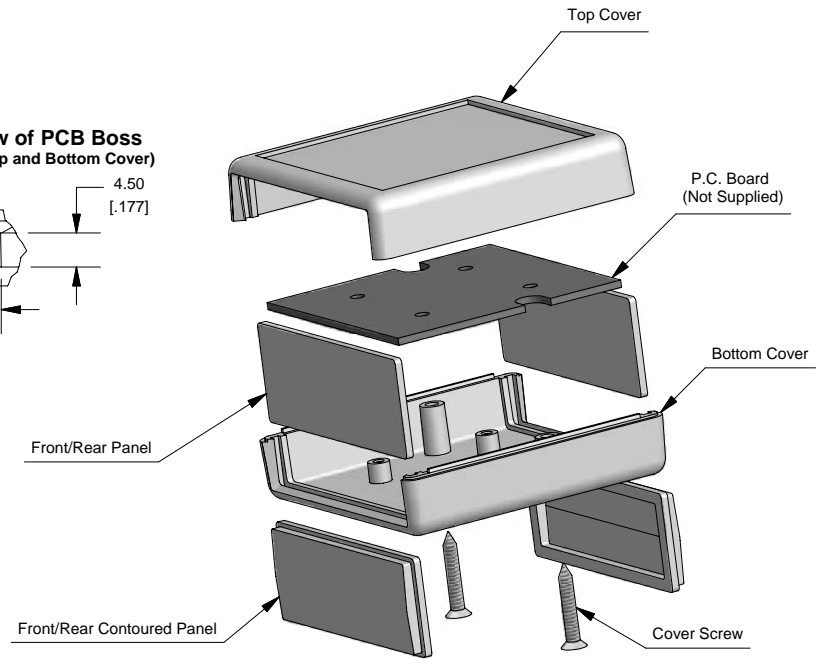

End View of Assembly

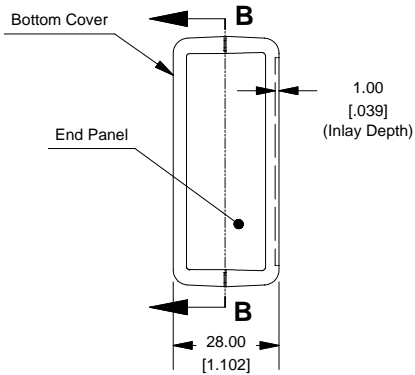

SECTION B-B (Inside of Bottom Cover)

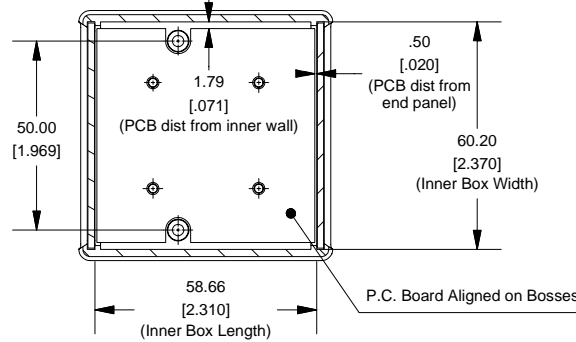

NOTE
Purchased assembly includes top and bottom cover, front and rear plastic panels (2 types - flat and contoured) and 2 cover screws.

Front/Rear Panel (Dashed Line Indicates Viewing Area)

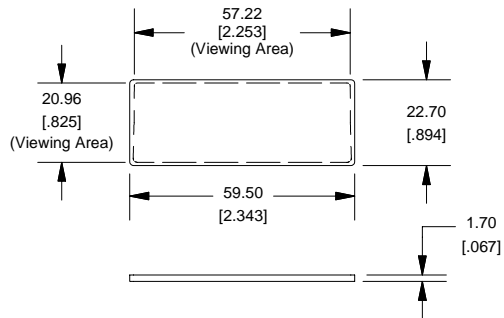

Maximum P.C. Board Size

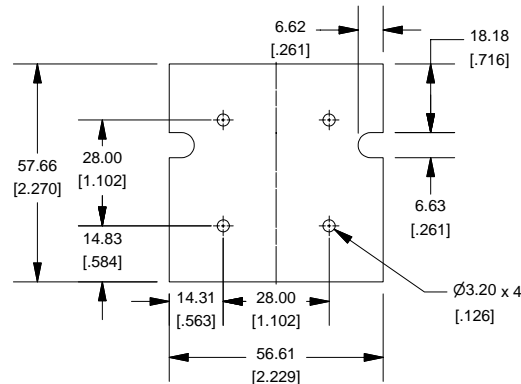

PART NUMBERS

1593K Enclosure	
Black Enclosure	1593KBK
Grey Enclosure	1593KGY
ACCESSORIES	
Cover Screws (Pkg 100) [#4 x 7/8" self-tapping oval head (22.2mm)]	1593KS100
P.C. Board Screws [#4 x 1/4" self-tapping (6.4mm)]	1593ATS50 (Pkg 50) 1593ATS100 (Pkg 100)
Belt or Pocket Clip	1599CLIP (Black) 1599CLIPGY (Grey)
Infrared Panels (Pkg 10)	1593PIR10

