

INTELLIGENT INDUSTRIAL SIGNAL LIGHTS



CLX-050-IOLink-M12

IO-Link Smart Signal Light

INDUSTRY 4.0 INTELLIGENCE



DIMENSIONS

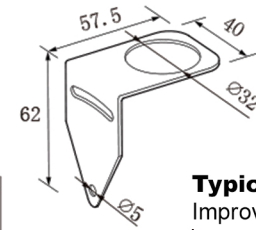
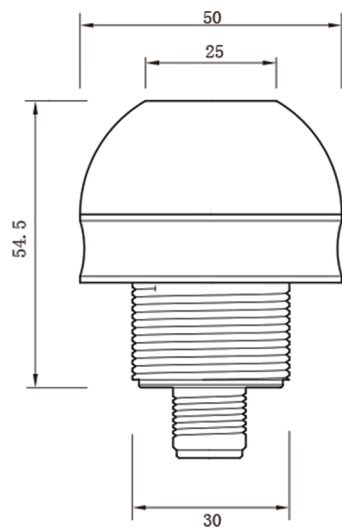

Typical Application

- Improve the optical signal for the error
- * Automated production line
 - * FTS
 - * Robots
 - * Switch cabinet
 - * Electronics
 - * Test equipment

CONTROL CIRCUIT DIAGRAM

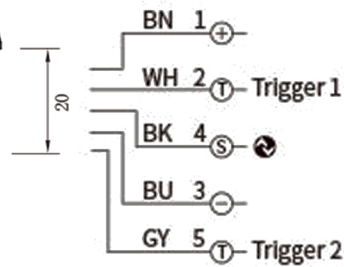
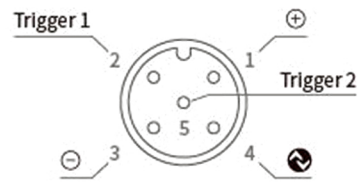

Pre-Sets / Factory settings		
Trigger1	Trigger2	Color
Lo	Lo	off
Hi	Lo	red
Lo	Hi	green
Hi	Hi	yellow