



>> Features 『特点』

- Small size, easy to install / 体积小，安装方便
- Maximum operating temperature of 100 °C / 最高工作温度100°C
- The minimum working voltage of 5.0V, Available mobile power supply/最低工作电压5.0V,可用移动电源供电
- The maximum operating voltage of 24V / 最高工作电压24V
- Can meet the high temperature food grade requirements / 可满足高温食品级要求
- Custom protection can be customized as required (Rotor lock protection/ Reverse polarity protection)
可按要求定制多种保护（堵转保护/极性反接保护）
- Epoxy potting, IP68 waterproof rating / 环氧树脂灌封，IP68防水等级

>> Application 『应用』

- 水族/Aquarium
- 水床/Water bed
- 无土栽培/No soil tailor
- 太阳能水循环系统/Solar water circulation system
- 沐足/Foot bath
- 喷泉/Fountain

>> Parameter 『参数』

No. 序号	Type 类别	Specification 规格	No. 序号	Type 类别	Specification 规格
1	product name 产品名称	DC brushless water pump 直流无刷水泵	8	Flow range 流量范围	9LPM
2	There is no zi function 有无自吸功能	No 无	9	noise 噪音	< 35dB
3	Outside diameter of inlet 进水口外径	Φ14mm	10	waterproof level 防水等级	IP68 (Can work in water and out of water) 水陆两用
4	Outlet diameter of outlet 出水口外径	Φ10.5mm	11	Life 使用寿命	20,000 hours 20000小时
5	Maximum operating temperature 最高工作温度	100°C	12	Power supply 供电方式	Suitable for solar panel, batteries, adapter or other power module 适用于太阳能板/电池/适配器及其它直流电源模块供电
6	Working voltage range 工作电压范围	5VDC-24VDC	13	Use liquid 使用介质	Water, tea, coffee and other non-viscous liquid 清水、茶、咖啡及其它非粘稠液体
7	Lift Head range 扬程范围	5M	14	Protective function 保护功能	polarity reverse /Rotor lock protection 极性反接/堵转保护

DS3502

>>Outward 『外观图』

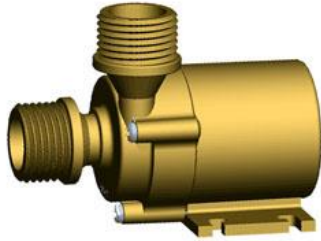

DS3502

>>Dimension 『尺寸图』

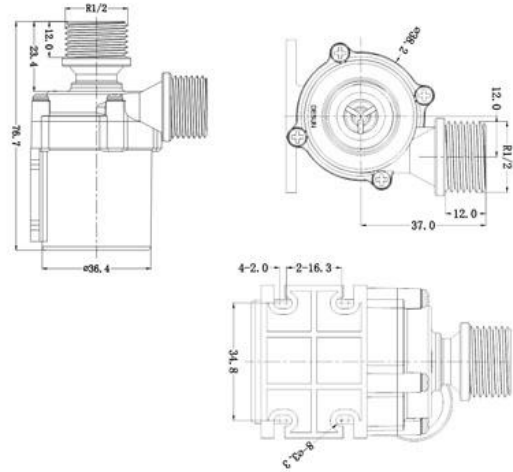

>>Electrical parameters 『电气性能』

Model 型号	Volts 电压 (V)	Amps 电流 (A)	Max flow 最大流量(LPM)	Max Lift head 最大扬程(M)	Power 功率 (W)
DS3502-1250	12	1	9	5	12
DS3502-2450	24	0.5	9	5	12

>>Flow-lift curve 『流量-扬程曲线图』

