

NOTES

- Parts: Enclosure base, lid and either 4, 6, or 8 (6-32) nickel plated machine screws. Painted boxes come with color matching screws. Replacement screws are available, see catalog for details.
- Options: Water resistant silicone seal by adding the letter "W" after 1590 in the part number. Silicone temperature range (-62 C to 232 C, "-80 F to 450 F")
- Finish: Unfinished (no suffix), Black powder ("BK" suffix), Gray Powder ("GY" suffix)

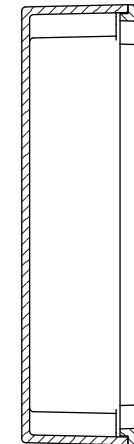

SECTION A-A
SCALE 1 : 1

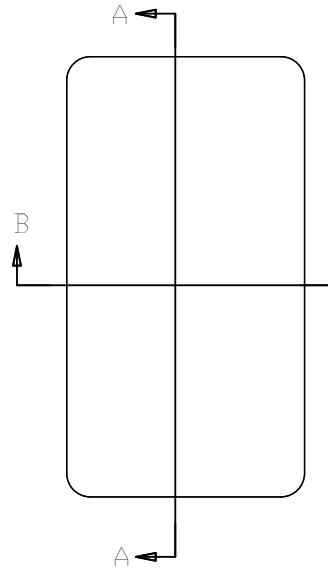
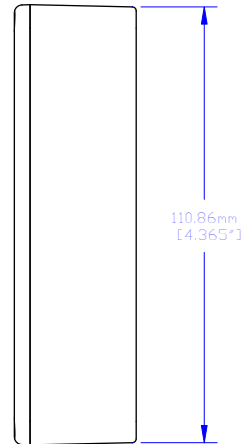
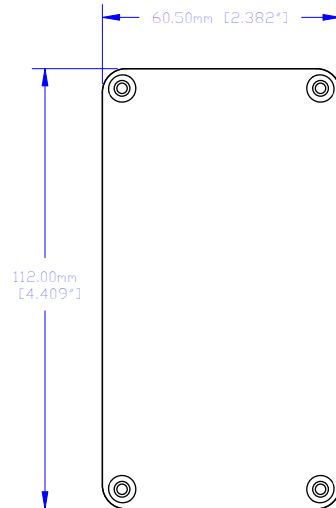
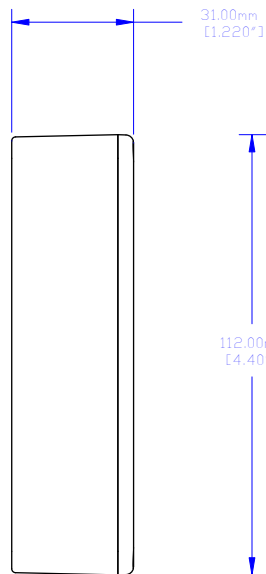
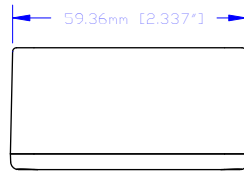
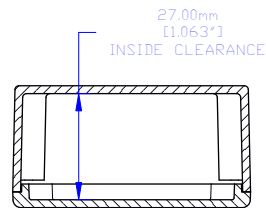
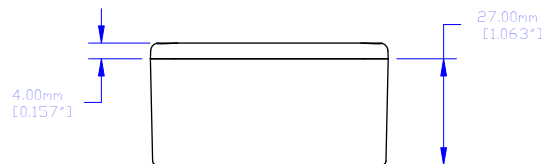
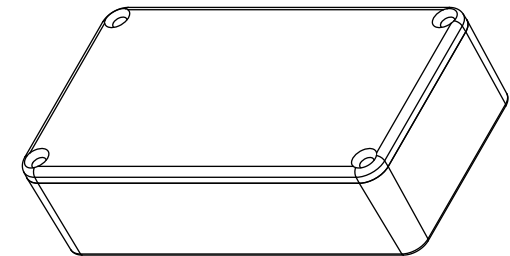

SECTION B-B
SCALE 1 : 1

For the best fit print on legal size paper.

THIS DRAWING IS PROPRIETARY INFORMATION OF HAMMOND MFG.CO.LTD. NOT TO BE USED WITHOUT EXPRESSED WRITTEN PERMISSION OF HAMMOND MFG.CO.LTD.

△	N/A	RELEASE	---	07 01 03	MJM
Rev	ECN	Description		Date	B

Unless otherwise spec'd dimensions are in millimeters
Tolerances are:

.X	±2.5
.XX	±1.50
.XXX	±.500
.XXXX	±.1300
Holes	±.1300
Angles	±.5°



Dwn	R. BOEHLER
Date	07 01 03
Chk	---
Mat'l	ALUMINUM DIECAST A 361 ALLOY
Sheet	1 of 1

HAMMOND MANUFACTURING CO., LTD.
Electronics Group, Waterloo, Ont. - Cheektowaga, NY

HAMMOND 1590 SERIES
DIECAST ALUMINUM

Part#: 1590B Dwg: 1590B/A1

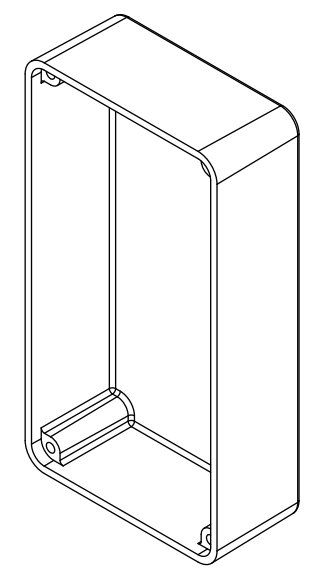
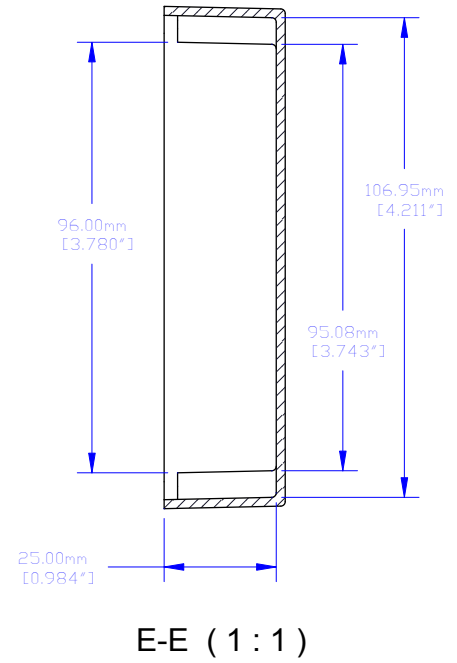
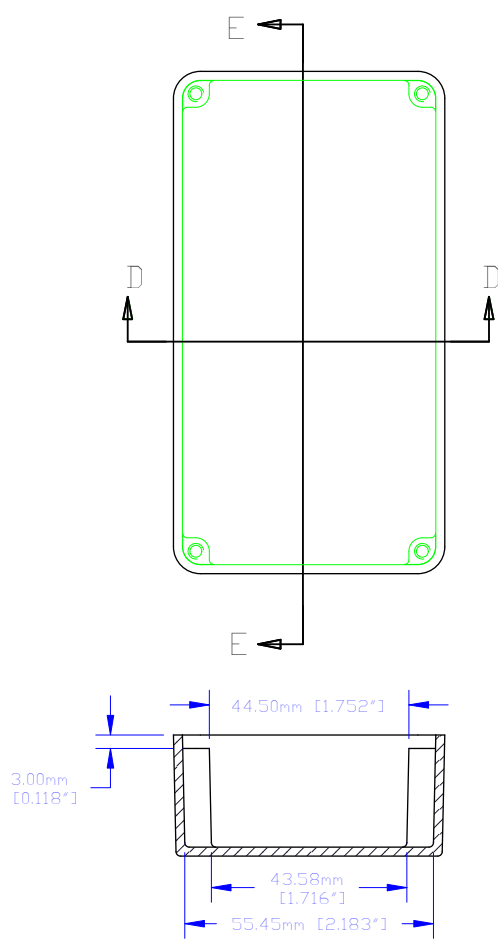
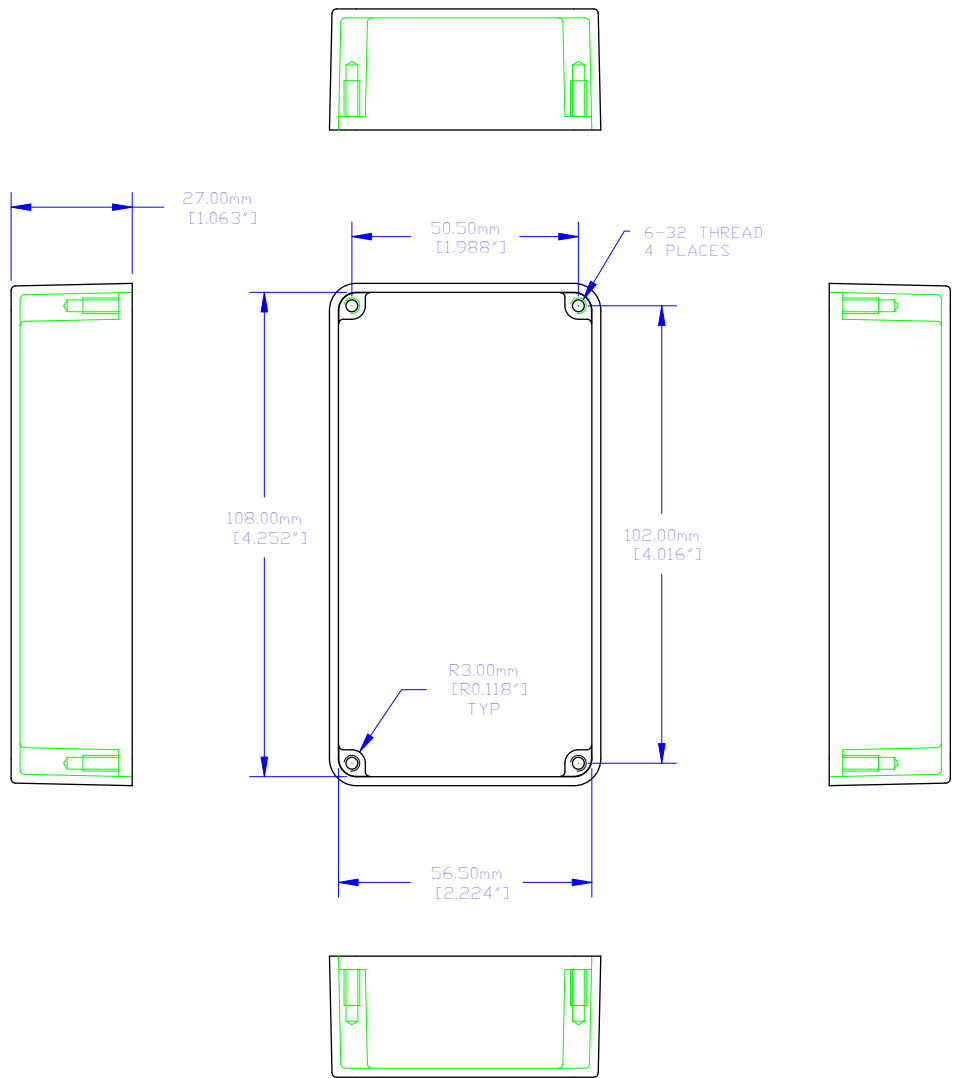

D-D (1:1)

E-E (1:1)

For the best fit print on legal size paper.

THIS DRAWING IS PROPRIETARY INFORMATION OF HAMMOND MFG.CO.LTD. NOT TO BE USED WITHOUT EXPRESSED WRITTEN PERMISSION OF HAMMOND MFG.CO.LTD.

△	N/A	RELEASE	----	07 01 03	MJM
Rev	ECN	Description		Date	B

Unless otherwise spec'd dimensions are in millimeters Tolerances are:

X	±25
.XX	±1.50
.XXX	±.500
.XXXX	±.1300
Holes	±.1300
Angles	±5°

Dwn	R. BOEHLER
Date	07 01 03
Chk	---
Mat'l	ALUMINUM DIECAST A 361 ALLOY
Sheet	1 of 3

HAMMOND MANUFACTURING CO. LTD.
 Electronics Group, Waterloo, Ont. - Cheektowaga, NY

HAMMOND 1590 SERIES
DIECAST ALUMINUM

Part#: 1590B Dwg: 1590B/A1

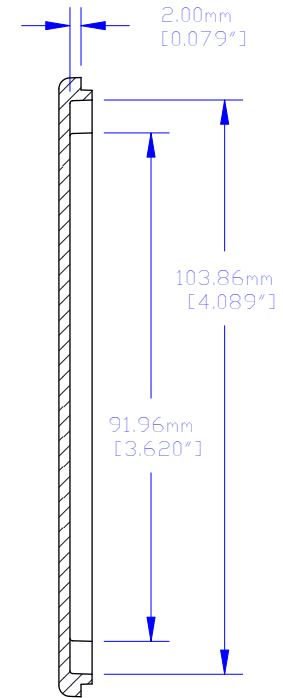
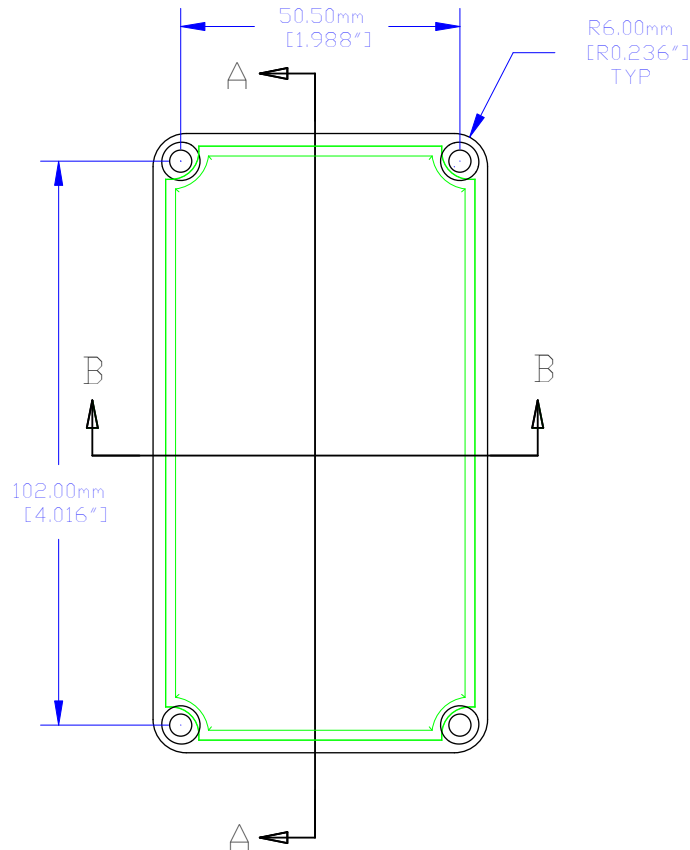
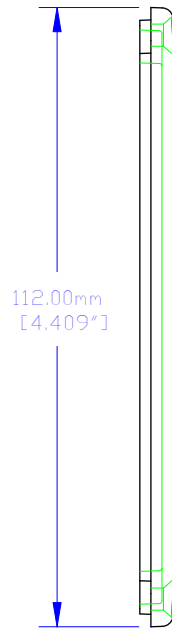
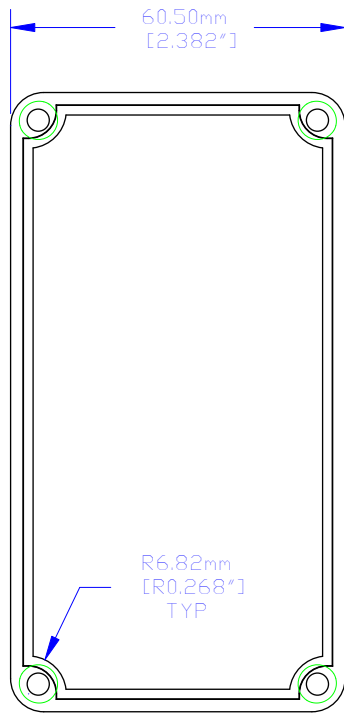

**SECTION A-A
SCALE 1 : 1**

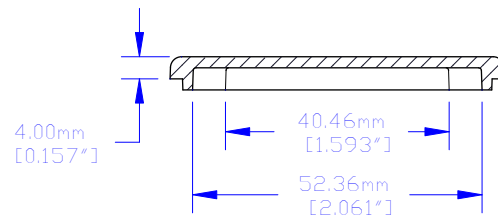

**SECTION B-B
SCALE 1 : 1**

For the best fit print
on legal size paper.

THIS DRAWING IS PROPRIETARY INFORMATION OF
HAMMOND MFG.CO.LTD. NOT TO BE USED WITHOUT
EXPRESSED WRITTEN PERMISSION
OF HAMMOND MFG.CO.LTD.

Rev	ECN	Description	Date	By
△	N/A	RELEASE	07 01 03	MJM

Unless otherwise spec'd
dimensions are in millimeters
Tolerances are:

X	±2.5
.XX	±1.50
.XXX	±.500
.XXXX	±.1300
Holes	±.1300
Angles	±5°

Dwn	R. BOEHLER
Date	07 01 03
Chk	---
Mat'l	ALUMINUM DIECAST A 361 ALLOY
Sheet	3 of 3

HAMMOND MANUFACTURING CO. LTD. Electronics Group, Waterloo, Ont. - Cheektowaga, NY	
HAMMOND 1590 SERIES DIECAST ALUMINUM	
Part#: 1590B	Dwg: 1590B/A1