

TOP VIEW

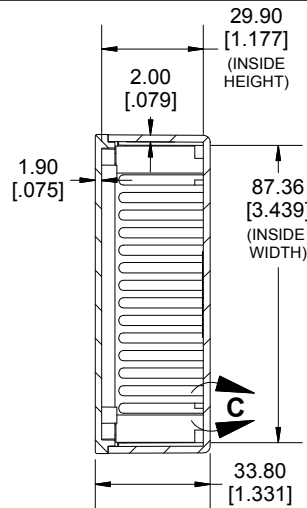

SECTION A-A

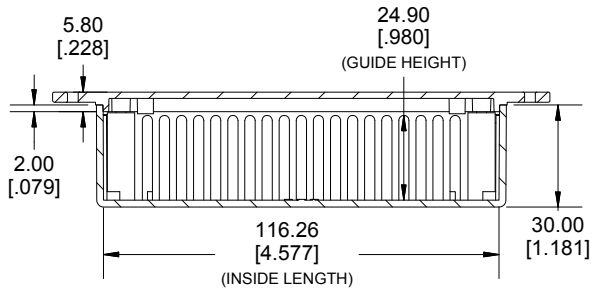
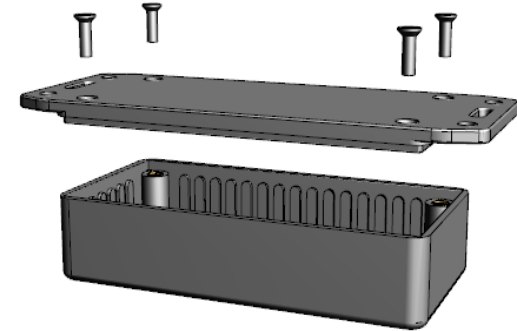

**SECTION B-B
SIDE VIEW**

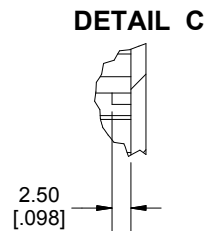

DETAIL C

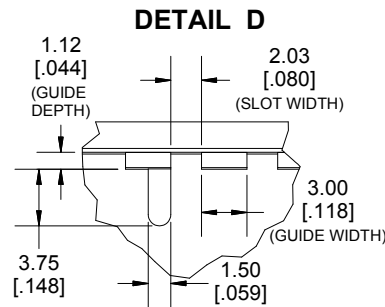

DETAIL D

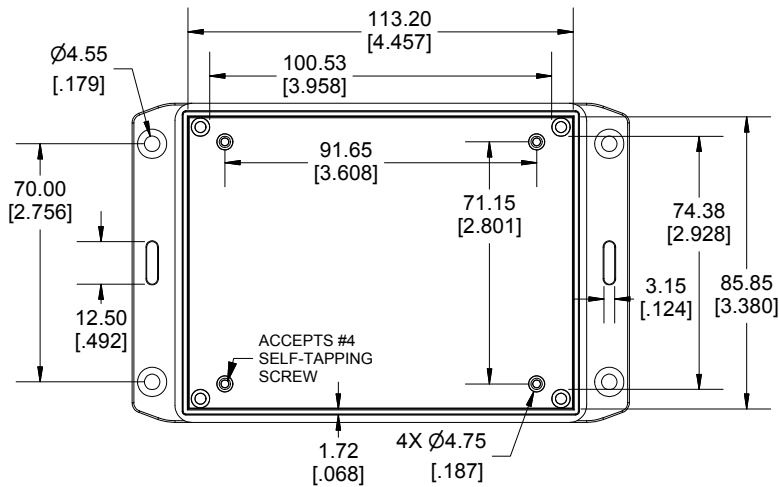

INSIDE LID

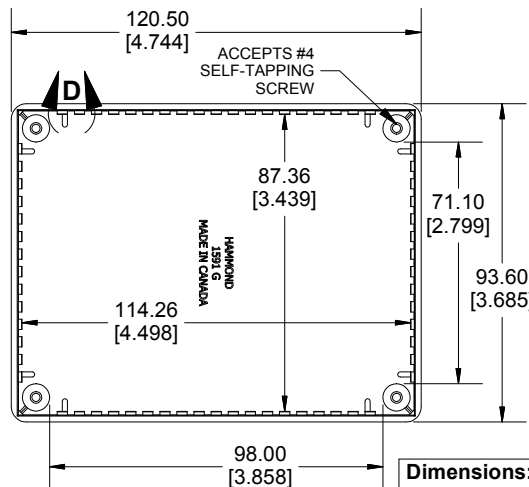

INSIDE BOX

Dimensions:
mm
[inches]

Enclosures can be Factory Modified (Milling, Drilling, Printing etc.)
Contact Factory mjm@hammondmfg.com for quotes
Solid models of this enclosure available in STEP or IGES.

NOTE	
Purchased assembly includes box, lid and 4 cover screws	
Enclosure made from GPABS.	
Recommended Torque: 42-57 ozf.in (30-40 cN.m)	

PART NUMBERS	
1591G Enlosure	
General Perpose ABS Black	1591GSFLBK
Accessories	
Plated Cover screw	1591TS100 (Silver)
#4 X 1/2" (100Pkg) Self-Tapping	1591TS100BK (Black)
P.C Board screws for Lid	1593ATS50 (50Pkg)
#4 X 1/4" (6.4mm) Self-Tapping	1593ATS100 (100Pkg)
PC Board Card Adapters	1591Z6 (6Pkg)
	1591Z50 (50 Pkg)
	1591Z100 (100Pkg)
Nylon Belt / Pocket clip	1599CLIP (Black)
	1599CLIPGY (Grey)

**HAMMOND
MANUFACTURING®**

1591GSFL

www.hammondmfg.com