

isc Silicon NPN Power Transistor

2SD5011

DESCRIPTION

- High Breakdown Voltage-
: $V_{CBO} = 1500V$ (Min)
- High Switching Speed
- High Reliability
- Built-in Damper Diode

APPLICATIONS

- Designed for color TV horizontal output applications

ABSOLUTE MAXIMUM RATINGS($T_a=25^\circ C$)

SYMBOL	PARAMETER	VALUE	UNIT
V_{CBO}	Collector-Base Voltage	1500	V
V_{CEO}	Collector-Emitter Voltage	800	V
V_{EBO}	Emitter-Base Voltage	6	V
I_C	Collector Current- Continuous	3.5	A
I_{CM}	Collector Current-Peak	10	A
P_C	Collector Power Dissipation @ $T_C=25^\circ C$	50	W
T_J	Junction Temperature	150	$^\circ C$
T_{stg}	Storage Temperature Range	-55~150	$^\circ C$

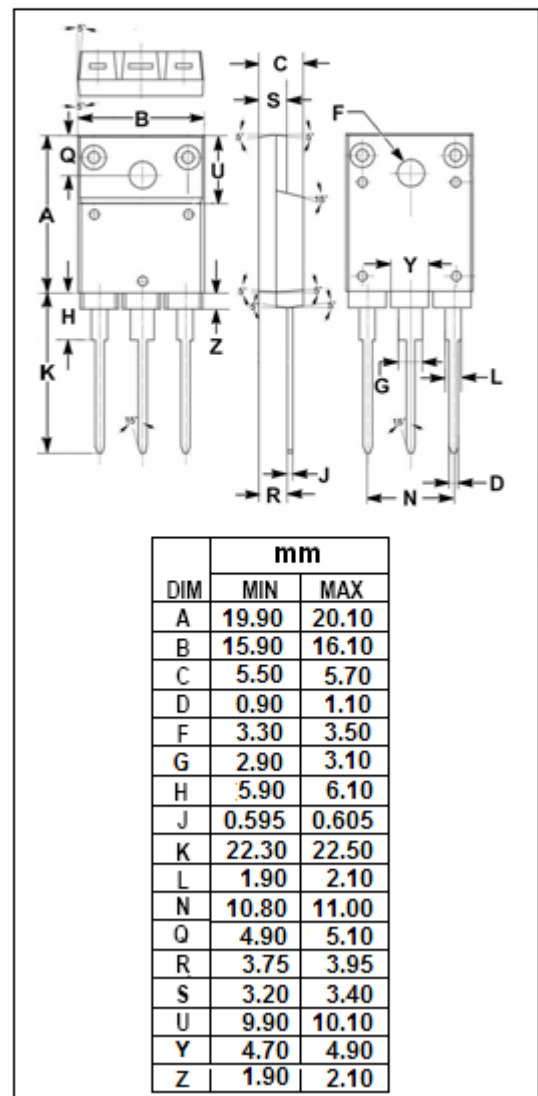
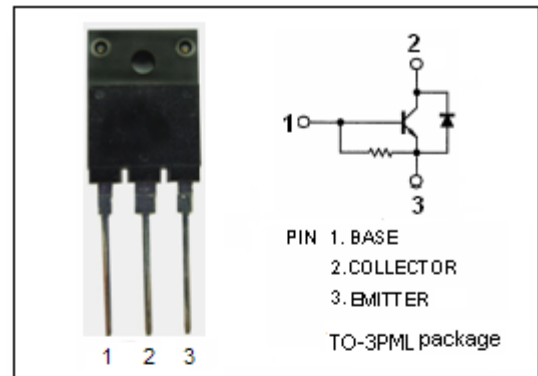

isc Silicon NPN Power Transistor**2SD5011****ELECTRICAL CHARACTERISTICS** $T_C=25^{\circ}\text{C}$ unless otherwise specified

SYMBOL	PARAMETER	CONDITIONS	MIN	TYP.	MAX	UNIT
$V_{CE(sat)}$	Collector-Emitter Saturation Voltage	$I_C=2.5\text{A}; I_B=0.8\text{A}$			8.0	V
$V_{BE(sat)}$	Base-Emitter Saturation Voltage	$I_C=2.5\text{A}; I_B=0.8\text{A}$			1.5	V
I_{CBO}	Collector Cutoff Current	$V_{CB}=800\text{V}; I_E=0$			10	μA
I_{EBO}	Emitter Cutoff Current	$V_{EB}=4\text{V}; I_C=0$	40		130	mA
h_{FE}	DC Current Gain	$I_C=0.5\text{A}; V_{CE}=5\text{V}$	8			
V_{ECF}	C-E Diode Forward Voltage	$I_F=3.5\text{A}$			2.0	V
f_T	Current-Gain—Bandwidth Product	$I_C=0.5\text{A}; V_{CE}=10\text{V}$		3		MHz
t_f	Fall Time	$I_C=3\text{A}, I_{B1}=0.8\text{A}; I_{B2}=-1.6\text{A}$ $R_L=66.7\ \Omega; V_{CC}=200\text{V}$			0.4	μs