

Product	<b>Contacts: 6 DIN, cable plug connector, short version, cable outlet 4 - 8 mm, gold plated contacts, UL approval</b>
Area	<b>M16 IP67 Series 423</b>
Article number	<b>99 5121 40 06</b>

Illustration	Scale drawing	Contact Arrangement																					
		<table border="1" style="margin: 10px auto;"> <thead> <tr> <th></th> <th>X</th> <th>Y</th> </tr> </thead> <tbody> <tr><td>1</td><td>3,03</td><td>-1,75</td></tr> <tr><td>2</td><td>3,03</td><td>1,75</td></tr> <tr><td>3</td><td>0,00</td><td>3,50</td></tr> <tr><td>4</td><td>-3,03</td><td>1,75</td></tr> <tr><td>5</td><td>-3,03</td><td>-1,75</td></tr> <tr><td>6</td><td>0,00</td><td>0,00</td></tr> </tbody> </table> <ul style="list-style-type: none"> <li>1 rot/red</li> <li>2 schwarz/black</li> <li>3 gelb/yellow</li> <li>4 blau/blue</li> <li>5 weiß/white</li> <li>6 grün/green</li> </ul>		X	Y	1	3,03	-1,75	2	3,03	1,75	3	0,00	3,50	4	-3,03	1,75	5	-3,03	-1,75	6	0,00	0,00
	X	Y																					
1	3,03	-1,75																					
2	3,03	1,75																					
3	0,00	3,50																					
4	-3,03	1,75																					
5	-3,03	-1,75																					
6	0,00	0,00																					

You can find the item description and assembly instruction on the next page.

## Technical data

### General features

Connector Design	Cable Connector
Connector locking system	bolted
Termination	solder
Wire gauge (mm)	0,75 mm <sup>2</sup>
Wire gauge (AWG)	20
Cable outlet	4 - 8 mm
Upper temperature	95 °C
Lower temperature	-40 °C

### Cable data

Approval 1	UL
------------	----

### Electrical parameters

Rated voltage	250 V
Rated impulse voltage	1500 V
Pollution degree	1
Overvoltage category	I
Material group	III
Rated current (40°C)	5 A
Volume resistivity	≤ 3 mΩ
EMV compliance	not shielded
Degree of protection	IP67
Mechanical operation	> 500 Mating cycles

### Material

Material of contact	CuZn (Messing)
Contact plating	Au (gold)
Material of contact body	PBT (UL 94 V-0)

Product **Contacts: 6 DIN, cable plug connector, short version, cable outlet 4 - 8 mm, gold plated contacts, UL approval**

Area **M16 IP67 Series 423**  
 Article number **99 5121 40 06**

Item description

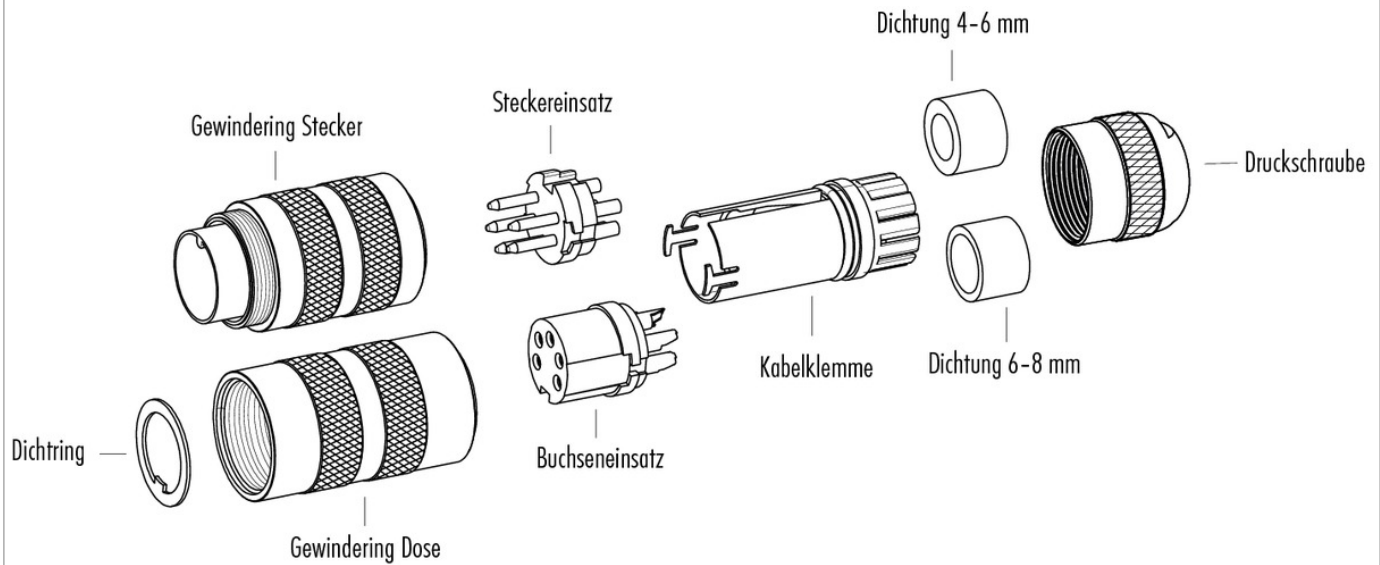

Installation instructions / Mounting cutout

**Gerade Version**

(Ausführung mit Schirmklemmung)

1. Druckschraube, Klemmkorb, Dichtung, Distanzhülse und ersten Schirmklemmring auffädeln.
2. Litzen abisolieren, Schirm aufweiten und zweiten Schirmklemmring auffädeln.
3. Litzen anlöten, Distanzhülse montieren, die beiden Klemmringe mit dem Schirm zusammenschieben und überstehenden Schirm abschneiden.
4. Übrige Teile gemäß Darstellung montieren.

**Straight version**

(Version with shield clamping ring)

1. Bead pressing screw, pinch ring, seal, distance shell and first shield clamping ring on cable.
2. Strip wires, widen shield and bead second shield clamping ring.
3. Solder wires, snap distance shell, push the two shield clamping rings together and cutt off projecting shielding braid.
4. Assemble remaining parts according to picture.

