

PHOTOELECTRIC TRIPLICATE BEAMS DETECTOR USER MANUAL

MODEL:50M 100M 150M 200M 250M

1.Parts Description

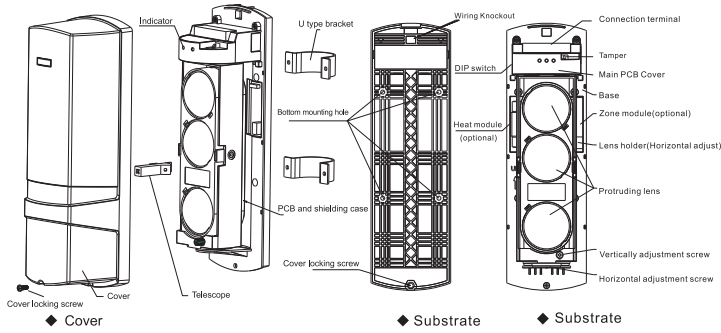

(2) Normal mounting:
Detection distance

Model	Detection distance	Beam spread angle
50	50m	1.6m
100	100m	2.0m
150	150m	2.8m
200	200m	3.8m
250	250m	5.0m

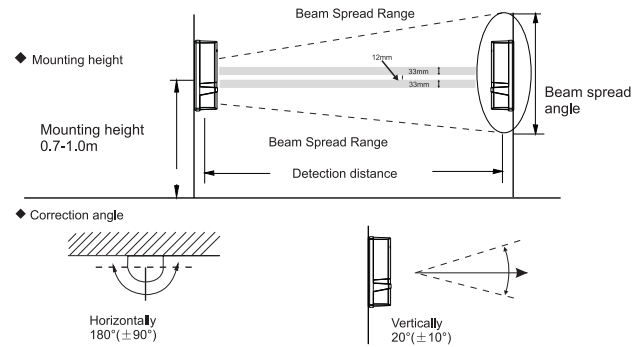

2.Setting Note

(1) Do not mount the detectors in following conditions

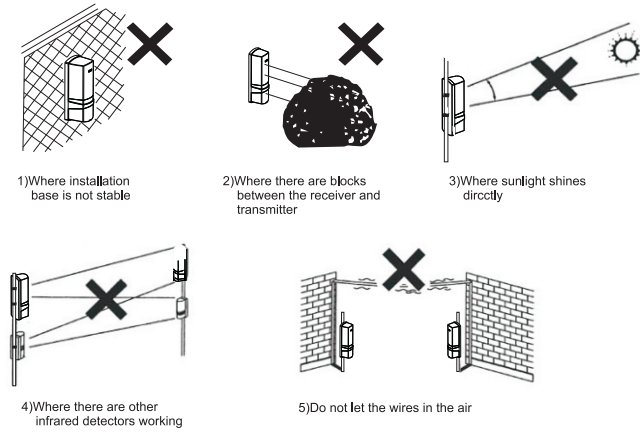

3.Setting method

◆ Wall mounting

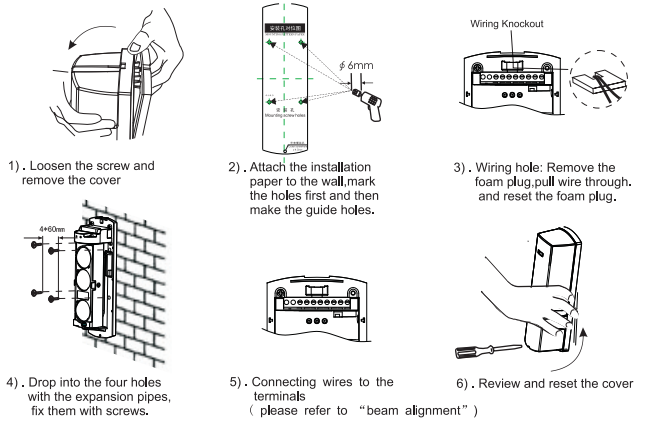

Pole mounting

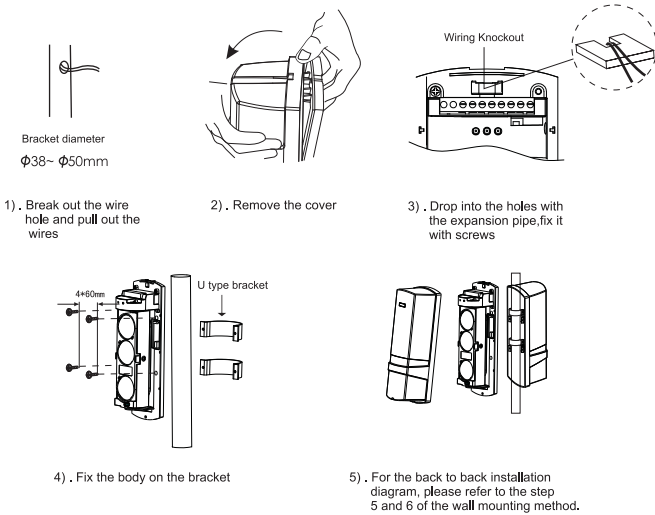

5. Connecting wires

(1) Examples

1.Single connect: Control panel operating voltage DC12V, NC alarm output, Connecting to power supply parallel (as follows)

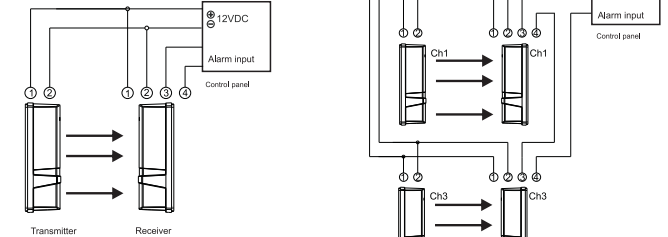

2.Stacked connect: Control panel operating voltage DC12V,NC alarm output series connect as follows:



3. Series connect;

Control panel operating voltage DC12V, NC alarm output series connect as follows:

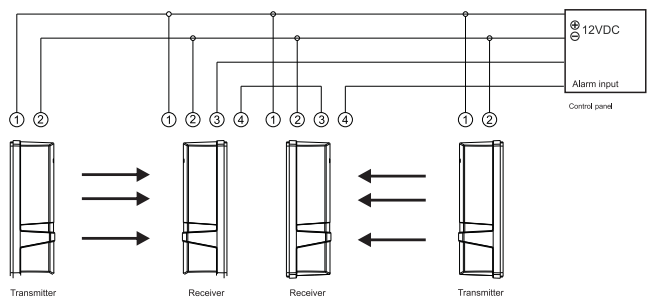

(2) The distance between the power and the detector should not be longer than following.

length	Voltage	DC12V	DC24V
Wire diameter			
0.5mm ² (diameter0.8)		400m	2000m
1.75mm ² (diameter1.0)		600m	3000m
1.0mm ² (diameter1.2)		800m	4000m
1.5mm ² (diameter1.4)		1000m	5000m

4.Connectors

⚠ (Warning): when installation, don't connect the port with the voltage or current which is over the normal specification!

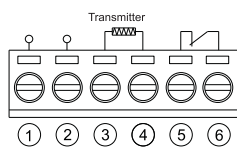

- Notes: 1. Power voltage input: DC/AC 12V-24V;
- 2. No heater in the package, please order if required.
- 3. The tamper switch is independent of other circuit; it would open if the cover was removed.

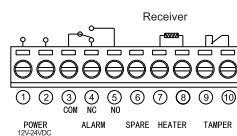

- Notes: 1. Power voltage input: DC/AC 12V-24V;
- 2. No heater in the package, please order if required.
- 3. The tamper switch is independent of other circuit; it would open if the cover was removed.
- 4. Relay connection point 1C 24VDC 0.5Amx

6. Digital tube voltage indicator

Digital tube indicator (on the right side of PCB shell)

- Adjust the beam frequency switch, make sure the frequency of transmitter must be the same as frequency of receiver.
- Adjust the screw and bracket until receiver can be seen and try to let its position in the line-of-sight center
- Adjust the screw and bracket until receiver can be seen and try to let its position in the line-of-sight center. The indication of digital tube will change between "0" to "9". "0" indicates no signal and alarm output. The calibration of the optical axis digital tube indicates "9".
- Operation confirmation. Please make sure the alarm indicator is off before testing. If not please redo the alignment until the detector into normal alarm state.

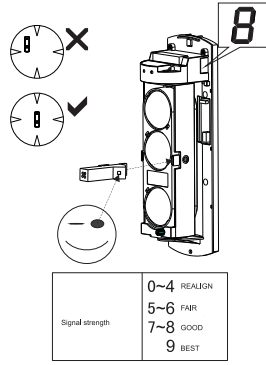

7. DIP switch

DIP switch description (DIP switch at the left side of the main PCB cover, as shown in picture)

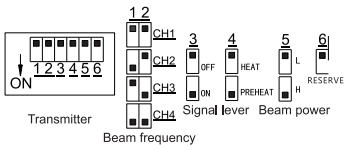

Transmitter:

- 1 and 2 two DIP switches to set the beam frequency, must be set the same as 1 and 2 two DIP switches' setting on receiver.
- Transmitter operating instructions, set it to off after debugging and set break code switch to off for saving energy.
- Pre-heating function helps to test heater heating function, its constant temperature is higher than heating. If customers buy heaters and use, keep it in the heating position to save power.
- The beam has two level power, please set according to the needs of the alert distance.

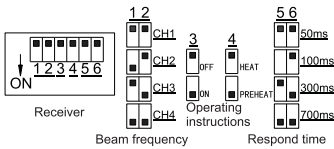

Receiver

- 1 and 2 two DIP switches to set the beam frequency, must be set the same as 1 and 2 two DIP switches' setting on transmitter.
- Transmitter operating instructions, set it to off after debugging and set break code switch to off for saving energy.
- Pre-heating function helps to test heater heating function, its constant temperature is higher than heating. If customers buy heaters and use, keep it in the heating position to save power.
- Interrupt time should be selected according to actual use.
- When interrupted occasionally by birds, leaves or paper, set longer respond time. And please double check when finished.

8. Beam frequency

When using some pairs beams or under long-distance applications, select a specific beam frequency to avoid mutual interference between beams.

When using in stack please set the frequency difference of 2, as show below, beams above set to

1, the under one set to 3, 2 and 4 frequency setting is the same as 1 and 3.

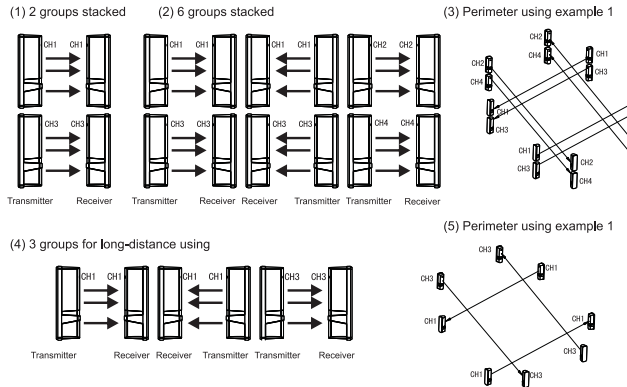

9. Operation confirmation

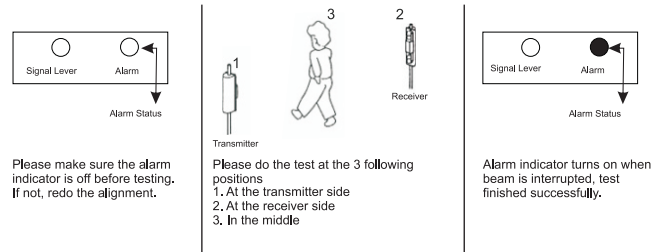

Please make sure the alarm indicator is off before testing. If not, redo the alignment.

Please do the test at the 3 following positions
1. At the transmitter side
2. At the receiver side
3. In the middle

Alarm indicator turns on when beam is interrupted, test finished successfully.

10. Troubleshooting

Symptom	Possible cause	Remedy
Power on, but indicator LED does not light (off)	1. DIP switch is in the state of saving electricity 2. Power cable without voltage; broken circuit or short circuit; polarity is incorrect; beyond specified voltage; power cable exceeds the specified length.	1. Turn on the DIP switch 2. Check power adapter, circuit and voltage polarity; change adapter or power cable
When beam is blocked, alarm LED does not light and alarm	1. There are reflectors or other transmitters impacting receiver 2. 3 beams are not all blocked 3. Setting too long interruption time 4. Alarm output cable is fixed incorrectly	1. Remove reflectors or close other transmitters; adjust receiver 2. Ensure 3 beams all blocked 3. Reduce interruption time 4. Check receiver terminal and output cable
When beam is not blocked, alarm LED lights and alarm	1. Beam is out of alignment; optical axis does not overlap 2. There are objects between receiver and transmitter 3. Frequency is incorrect 4. The cover is dirty or capped by snow, frost and ice 5. Transmitter dose not output	1. Adjust optical axis 2. Check objects between receiver and transmitter 3. Ensure the frequency of receiver and transmitter the same 4. Clean cover and use heater 5. Check the power, current and cable of transmitter
False alarm	1. Bad wiring and fluctuant power voltage 2. Movable blocks, like bird, paper, leaves 3. The installation base is unstable 4. Out of alignment 5. Frequency of transmitter is set "L"	1. Check power, current and wiring voltage 2. Change the installation location 3. Strengthen installation base 4. Adjust optical axis 5. Change Frequency of transmitter from "L" into "H"

11. Specifications

Model	50	100	150	200	250
Detecting distance(outdoor)	50m	100m	150m	200m	250m
Detecting distance(indoor)	150m	300m	450m	600m	750m
Detecting distance (Max)	300m	600m	900m	1200m	1500m
Detection method	Simultaneous interruption of 3 infrared beams				
Interruption time	50ms, 100ms, 300ms, 700ms (adjustable)				
Number of beams	3 beams				
Frequency	4 (optional, but transmitter should be same with receiver)				
Alarm cycle	2±1s				
Tamper	NC, Works when cover is removed				
Current consumption (Max)	70mA	80mA	90mA	100mA	110mA
Power and Voltage	DC12-24V; AC11-18V				
IP rating	IP 65				
Operating temperature	-25℃—55℃				
Humidity	95% MAX				
Alarm output	Relay output 1C, contact output, DC/AC30V/0.5A Max.				
Correction angle	Horizontally 180°; vertically 20°				
Installation location	Indoor/outdoor, wall/pole				
Weight	1.9KG				

12. Dimensions

