

Overview

Vision Technology provides safe LiFePO4 battery solutions for UPS and Energy storage system. This battery system serves for UPS and Energy storage system with perfect compatibility and safe long cycle life.

Features

- Customized protection board functions and parameters;
- Intelligent balance management;
- Built-in automatic protection for over-charge, over-discharge and over-temperature;
- This BMS supports a matrix of 4 battery in series X 4 battery in parallel. A total of 16 batteries in the matrix.

Module Preview

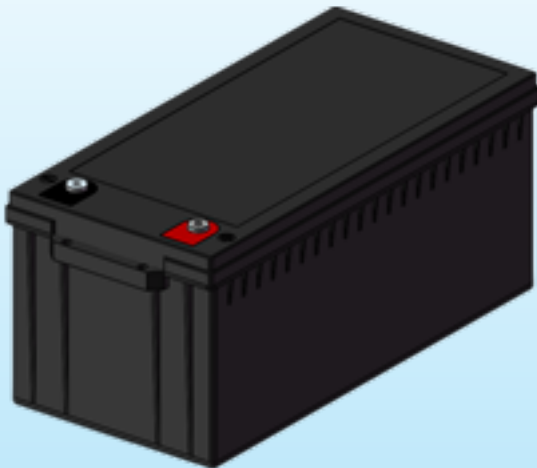

12.8V200AH

Performance Data

Time(min)	120	180	240	360	480
Constant Power(kw)	1.12	0.74	0.56	0.42	0.30
Constant Current(A)	100	66.6	50	33.3	25

Rack Specification

Voltage Range(V)	11.2 ~ 13.8	
Cell	3.2V100Ah	
Cell Series & Parallels	4S2P	
Rated Voltage(V)	12.8	
Rated Capacity(Ah)	200	
Rated Energy(KWh)	2.56	
Maximum Charge Current(A)	100	
Discharge cut-off voltage(V)	11.2	
Charge voltage(V)	13.6 ~ 13.8	
Life cycle (@25°C ,1C/1C,100%DOD)	Approx 2500	
Short-circuit current (< 10ms)	Approx.1000A	
Dimension(W* D* H)	(522*238*223) mm	
Total Weight(Kg)	Approx.20	
Internal Resistance Fully Charged@ 25	10mOhms	
Thermal Management	Air cooling	
Operating temperature	charge	0 ~ 50
	discharge	-20 ~ 65
Operating humidity	60 ± 25%R.H.	
BMS system series	4	
BMS system parallels	4	

Module size

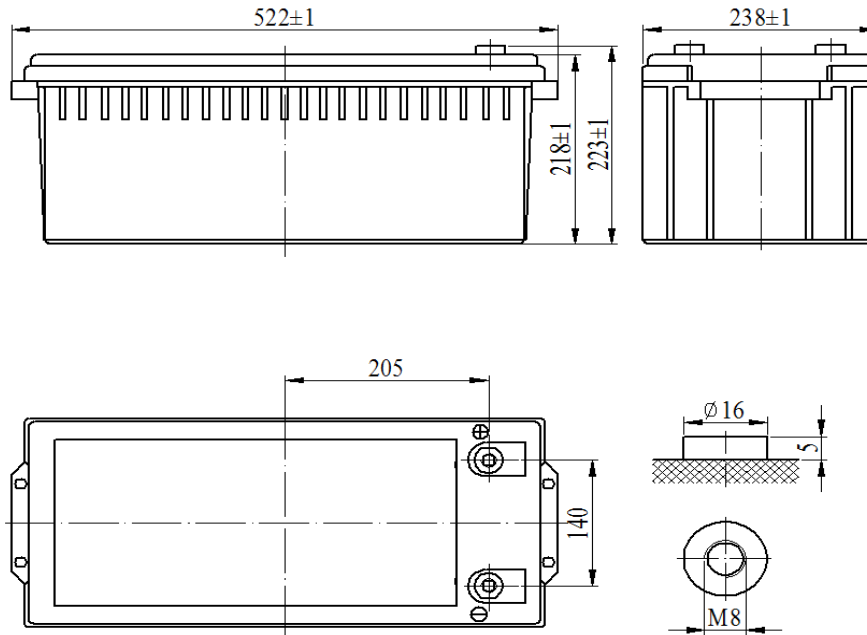

Characteristics Curve

Discharge Performance at 25°C

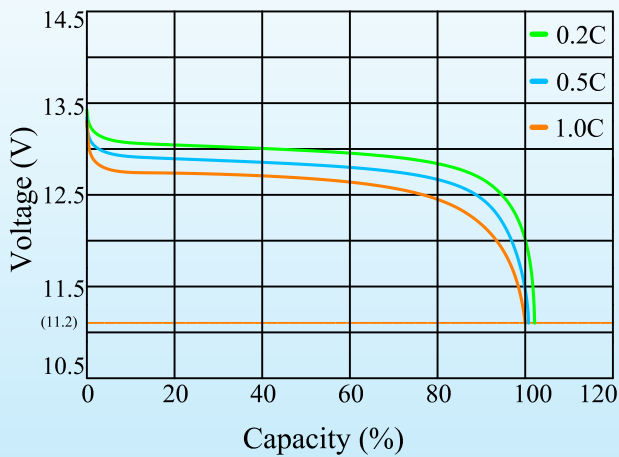

Charge and Discharge at 25°C, 0.5C

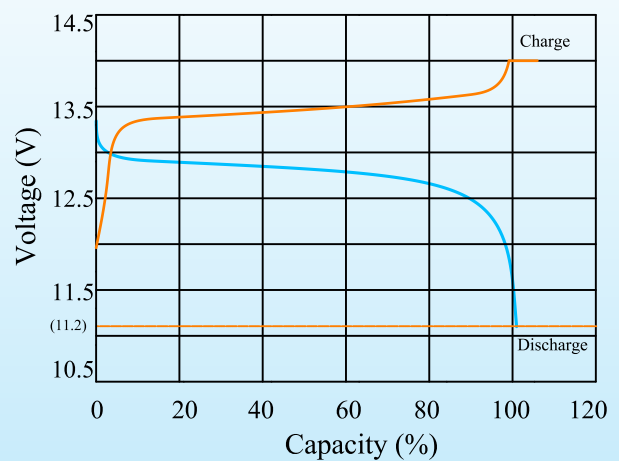

Temperature effects on capacity at 0.5C

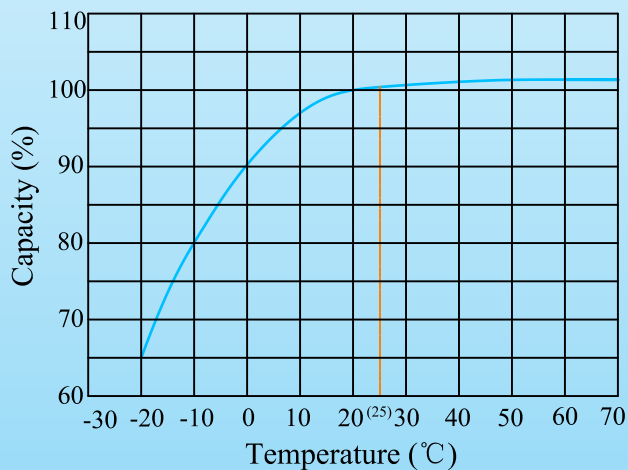

Cycle life with DOD at 25°C
1C discharge and 1C charge

