

Sealed maintenance-free lead-acid batteries series DTM L DELTA brand are manufactured by AGM technology (electrolyte absorbed in glass fiber separators) and equipped with VRLA valves. Series DTM L refers to a Long-Life series with a service-life up to 12 years.

Due to a wide range of batteries and their high performance, are recommended for use in a variety of uninterruptible power supply systems, including exacting electrical appliances (submersible and circulation pumps, boilers of heating systems), emergency power supply and other electrical devices.



### Battery construction

Element	Positive plate	Negative plate	Case	Lid	Valve	Terminal	Separator	Electrolyte
Material	Lead dioxide	Lead	ABS		Rubber	Copper	Fiberglass	Acid

### Specifications

Nominal voltage.....	12 V
Cell.....	6
Design life.....	10-12 years
Nominal capacity (25°C)	
10 hours rate (10 A; 1,8 V/cell).....	100 Ah
5 hours rate (16,83 A; 1,75 V/cell).....	84,15 Ah
1 hours rate (63,05 A; 1,6 V/cell).....	63,05 Ah
Self-discharge.....	3% capacity per month 25°C
Internal resistance (25°C).....	5 mΩ

### Operating temperature range

Discharge.....	-20÷60°C
Charge.....	-10÷60°C
Storage.....	-20÷60°C
Maximum discharge current (25°C).....	900A (5sec)
Cycle mode (2,35÷2,4 V/cell)	
Max.charge current.....	30 A
Temperature correction factor.....	30 mV/°C
Standby mode (2,25÷2,3 V/cell)	
Temperature correction factor.....	20 mV/°C

### Application

- Uninterruptable power supply
- Back up power supply
- Medical devices
- Wheelchair
- Space-heating system
- Renewable energy systems

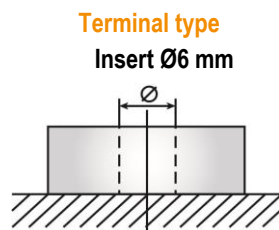
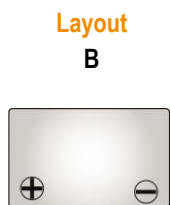

### Performance & characteristics

- AGM technology allows to recombine 99% of the generated gas;
- No restrictions on air transportation;
- Compliance with the UL requirements;
- Lead plates, alloyed by calcium, provide high energy density;
- Maintenance-free. Do not require distillate topping;
- Long service life;
- The battery case is made of flame-retardant ABS plastic.

### Dimensions (±2mm)

Length, mm.....	330
Width, mm.....	171
Height, mm.....	215
Height over terminals, mm.....	220
Weight (±3%), kg.....	29

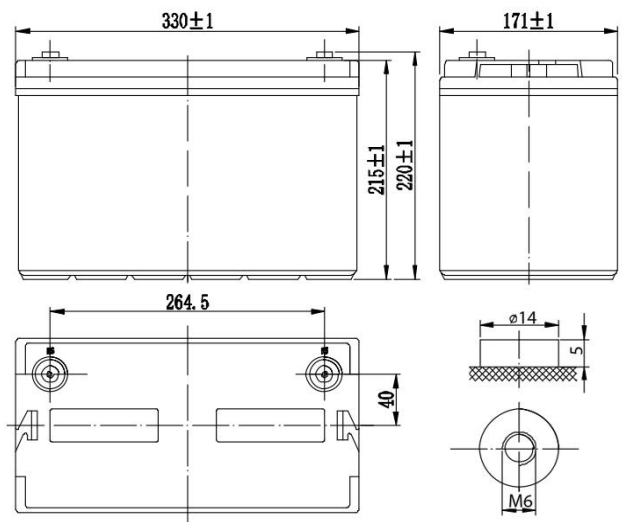

**Discharge Constant Current, A ( 25°C)**

V/cell	5 min	10 min	15 min	30 min	45 min	1 h	3 h	5 h	10 h
1,60	296	212	173	102	75,9	63,1	26,8	18,3	10,8
1,65	281	205	166	98,1	74,3	59,5	26,6	17,6	10,6
1,70	251	185	153	90,6	68,9	58,6	26,2	17,3	10,5
1,75	234	173	143	87,7	67,3	57,6	25,9	16,8	10,3
1,80	217	162	134	85,9	66,0	54,7	24,3	16,5	10,0

**Discharge Constant Power, W/cell ( 25°C)**

V/cell	5 min	10 min	15 min	30 min	45 min	1 h	3 h	5 h	10 h
1,60	542	384	326	193	143	116	49,7	35,2	20,5
1,65	515	381	312	186	140	110	49,6	34,1	20,3
1,70	477	354	297	173	131	109	48,9	33,7	20,2
1,75	452	341	285	169	128	108	48,8	33,0	20,1
1,80	439	329	274	166	127	103	45,9	32,5	19,2

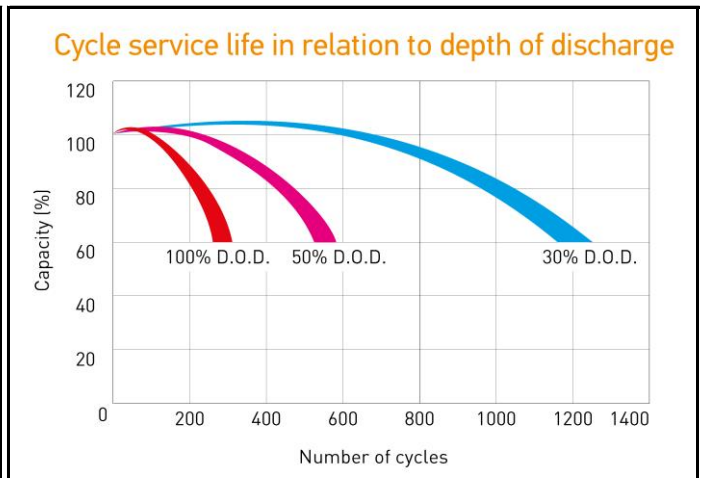
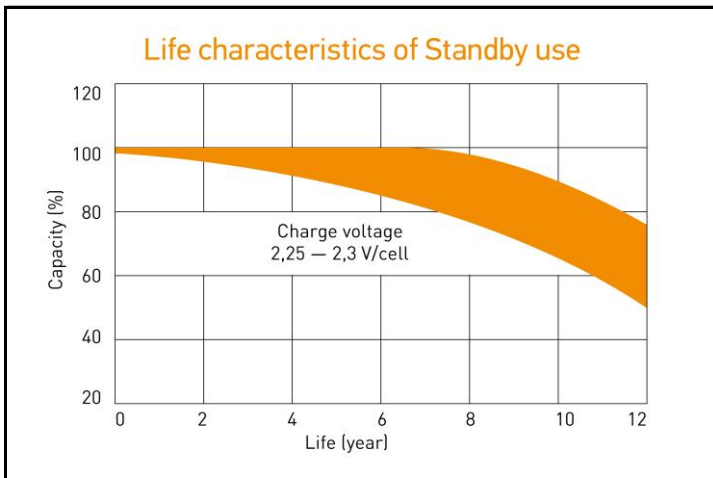
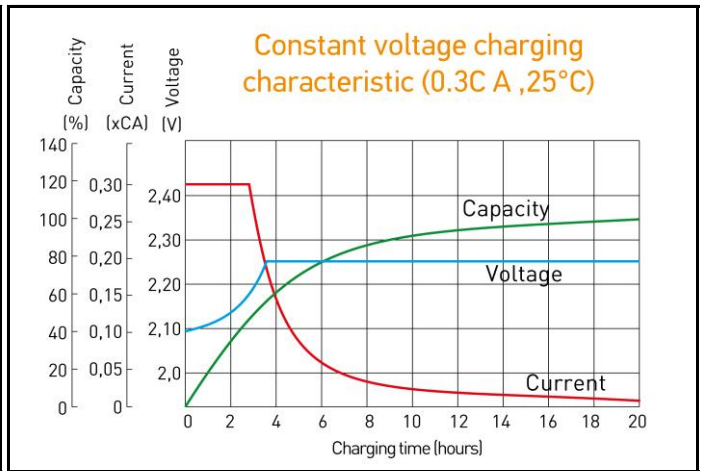
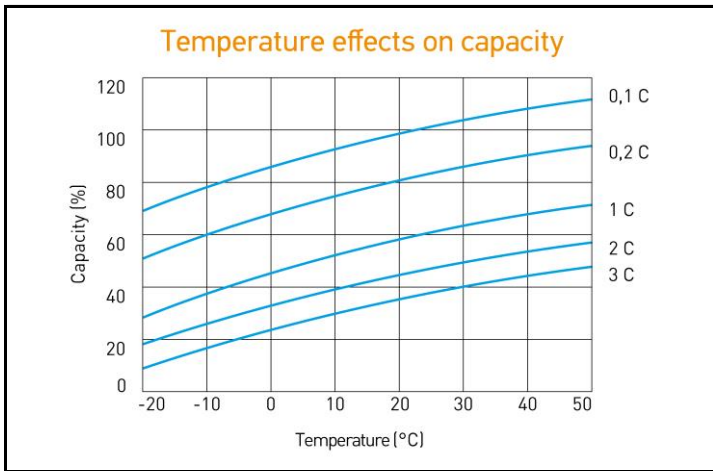

ALL DATA IS SUBJECT TO CHANGE WITHOUT NOTICE