

# THE DATALINE SERIES

12-00011 /12-00012/ 12-00087

## Data protection Modules

### Features

- Easy installation
- Screw termination

#### Applications:

- General small signal line protector

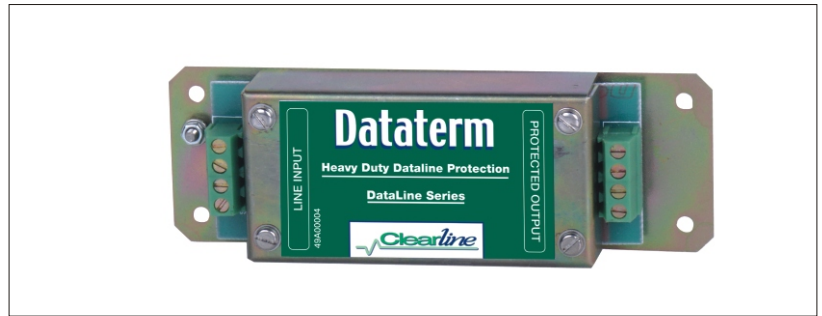

Specifications	Series 130
Max. operating voltage Vmax	See order code table
Max. continuous current	0.3A
Max. discharge current (Differential mode)	10kA
Max. discharge current (Common mode)	10kA
Response time	10ns
Residual voltage (Differential mode)	Approx. 1.8Vmax
Residual voltage (Common mode)	Approx. 1.8Vmax
Temperature range	-20 C to +70 C

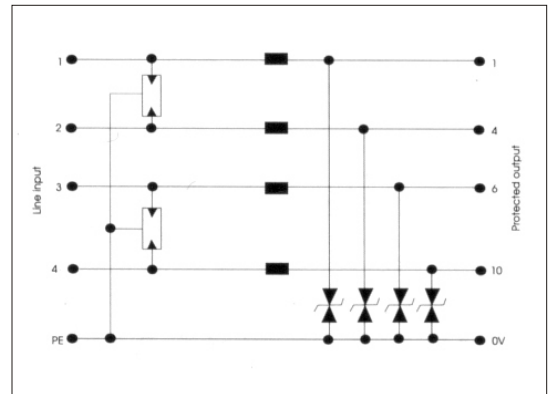

Series 130

Order code	130 series
Voltage	6 way
+/- 6Vdc	12-00011
+/- 15Vdc	12-00012
+/- 25Vdc	12-00087

### Dimensions

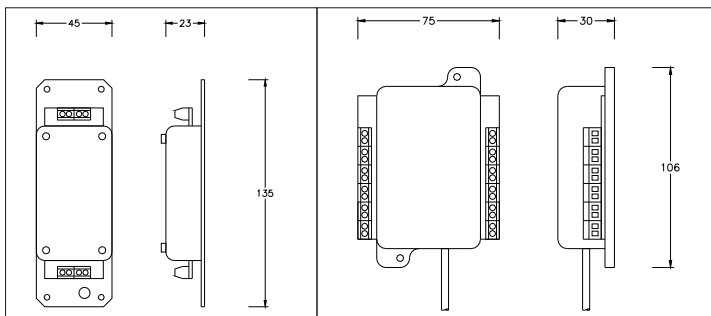

#### Designed and Manufactured by:

**Clearline Protection Systems (Pty) Ltd**

Roan Crescent Corporate Park North, Old Pta Road, Midrand, South Africa

P.O. Box 5985, Halfway House, 1685

Tel: +27 (0) 11 848-1111

Fax: +27 (0) 11 314-3880

E-mail: sales@clearline.co.za

www.clearline.co.za



ISO 9001

