

THE DUOLINE SERIES

12-00198

rev_2

Television and DSTV Protection

Features

- Plug-and-Play concept
- High surge capability
- Fire hazard protection
- Protection indication lamps

Clearline protects your Television, Mnet, PVR, decoder, Satellite decoder and VCR against lightning and surges without additional earthing.

The protection modules have multiple stages of protection capable of blocking severe lightning and power surges.

Clearline incorporates a fast overload device which will be activated in extreme conditions. Functional indication lamps display the protection status of the unit.

Clearline's unique built-in thermal protection devices eliminates fire hazards.

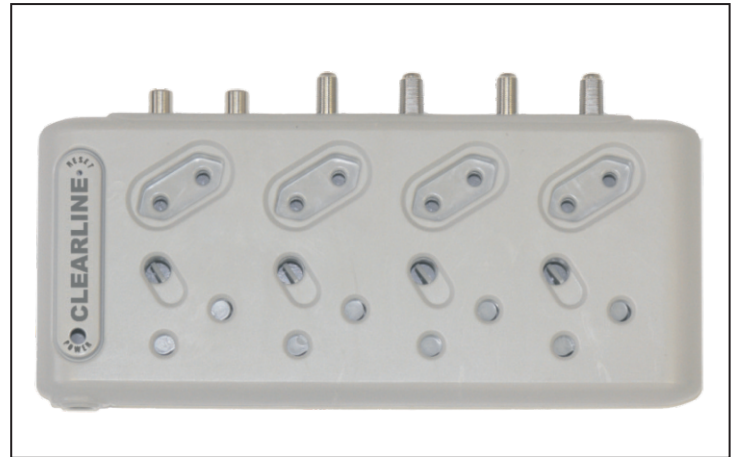

*Subject to change without prior notice due to continuous improvements

Specifications	
Power Surge Protection	
Nom. Input Voltage	230VAC 50Hz
Max. Continuous Current	16A
Max. Discharge Current	4.5kA L-N, L-E, N-E (8/20us)
Residual Voltage	<900V
Response Time	<25ns
Input Connectors	16A 3Pin Plug
Output Conenctors	4x 3Pin + 4x 2Pin Sockets

TV/Satellite Surge Protection	TV	Satellite
Max. Discharge Current	10kA (8/20us)	10kA (8/20us)
Residual Voltage	<100V	<100V
Response Time	<100ns	<100ns
Frequency Response	800MHz	3GHz
Connectors	PAL	F-Type

Other	
Indication	Neon Lamp
Temperature Range	0C to +40C
Standard Compliance	IEC 61643-1
Lead Length	285mm
Dimensions	254x112x34mm
Weight	0.64kg

Dimensions

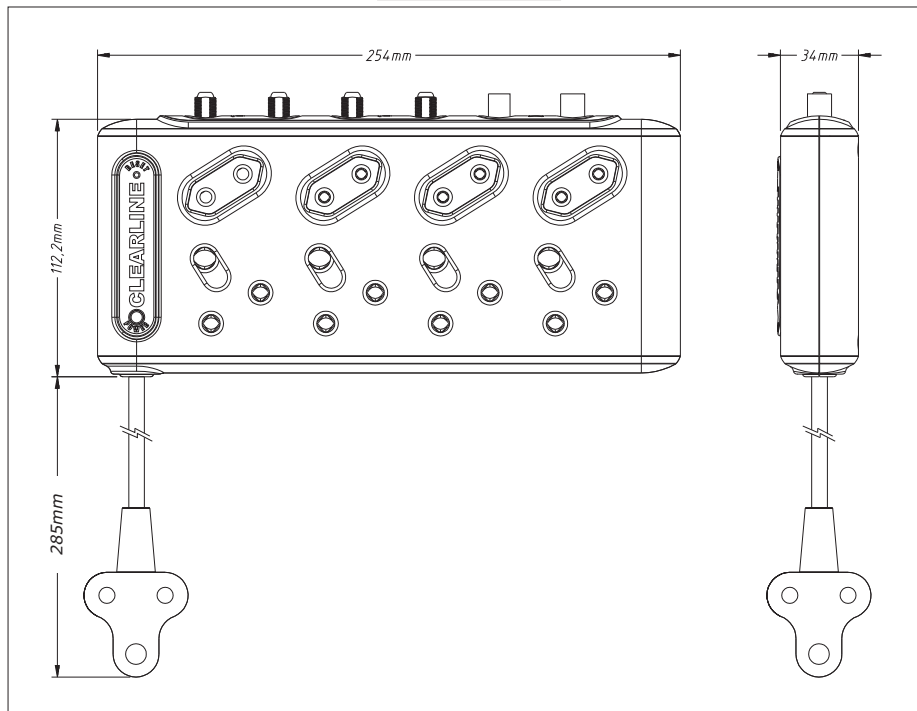

Designed and Manufactured by:

Clearline Protection Systems (Pty) Ltd

385 Roan Crescent Corporate Park North, Old Pta Road,

Midrand, South Africa

P.O. Box 5985, Halfway House, 1685

Tel: +27 (0) 11 848-1100

Fax: +27 (0) 11 314-3880

E-mail: info@clearline.co.za

www.clearline.co.za



