

THE POWERLINE SERIES

Econo PABX Filter

Features

- Built in surge suppression
- High surge capability
- Compact design
- Effective filtration
- Earth connected indicator

The econo-pabx filter was designed to be a cost effective solution for mains filtration. The unit has a single stage filter capable of up to 60dB of attenuation of noise. High energy surge suppression has been fitted as standard.

Also included is our standard surge module that will disconnect the load from the mains in the event of a fault thus preventing a fire hazard.

Another feature is the indication board that will notify the user when power is connected, if there is a earth connection and a LED if the protection goes faulty.

Specifications	
Power Surge Protection	
Nom. Input Voltage	230VAC 50Hz
Max. Continuous Current	16A
Max. Discharge Current	8kA L-N, L-E, N-E (8/20us)
Residual Voltage	<900V
Response Time	<25ns
Input Connectors	Male connectors
Output Connectors	Male connectors

Other	
Indication	LED
Temperature Range	-20°C to +70°C
Standard Compliance	IEC61643-1
Lead Length	N/A
Dimensions	85x56x31.5mm
Weight	4.4kg

Filtration	
Filtration Performance	See graph on page2
Earth Leakage Current	<1.5mA

12-00910

rev1



*Specifications subject to change without prior notice due to continuous improvements

Dimensions

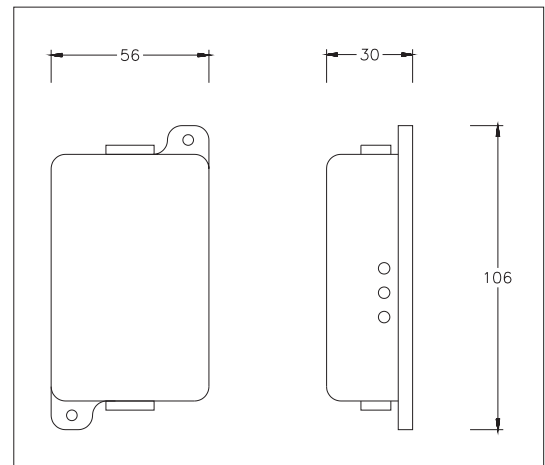

Filter Response

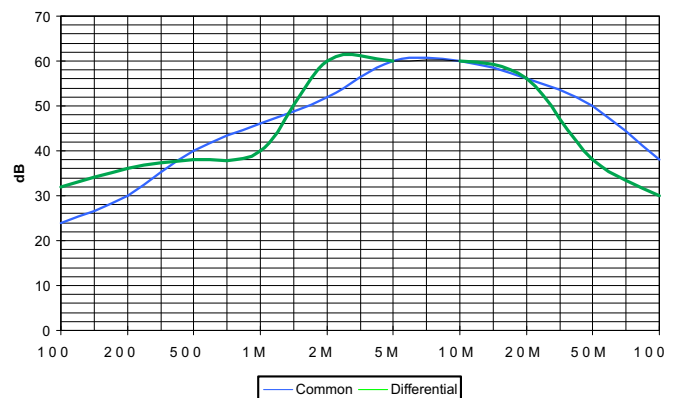

Designed and Manufactured by:

Clearline Protection Systems (Pty) Ltd

385 Roan Crescent Corporate Park North, Old Pta Road,

Midrand, South Africa

P.O. Box 5985, Halfway House, 1685

Tel: +27 (0) 11 848-1100

Fax: +27 (0) 11 314-3880

E-mail: info@clearline.co.za

www.clearline.co.za

