



SPECIFICATIONS SHEET

PRODUCT TYPE : PIEZO BUZZER

PRODUCT SERIES : DB-E298

DESCRIPTION : PZ BUZZER FAST PULSE 12VDC L/W ABS SP RoHS

COLOR : BLACK

ELECTRICAL SPECIFICATIONS

MODEL NO.		29PF3120LF - LA
OPERATING VOLTAGE RANGE (VDC)		3.0 ~ 28.0
RATED VOLTAGE (VDC)		12.0
* MAX. RATED CURRENT (mA)		9.0
* MIN. SOUND OUTPUT (dBA/ 30 cm)		90.0
* FREQUENCY (Hz)		2900 +/- 500
TONE NATURE		FAST PULSE (1 min 95 times)
OPERATING TEMPERATURE (°C)		- 20 ~ +60
TERMINAL		LEADWIRE (UL1007 , AWG#28)
HOUSING MATERIAL		ABS
WEIGHT (g)		15.0

* Value applying at rated voltage

DIMENSIONS

UNIT : mm

TOP VIEW

SIDE VIEW

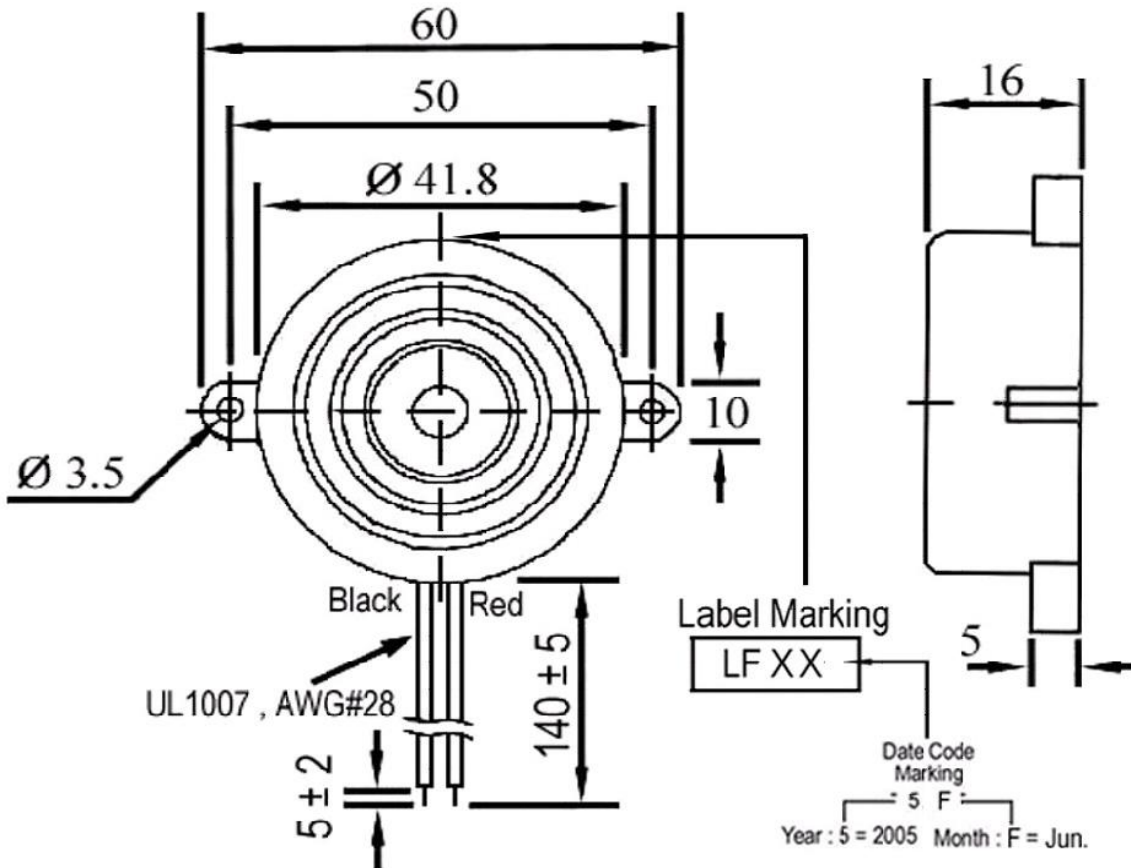

Approved By : 
Date : 5-Nov.-2008

Prepared By : 
Date : 5-Nov.-2008

Modify :	Date :
Modify the label marking	05-Nov-08

By :
hoyin