

Ultrasonic ranging module : HC-SR04

Specifications:

power supply :5V DC

quiescent current : <2mA

effectual angle: <15°

ranging distance : 2cm – 500 cm

resolution : 0.3 cm

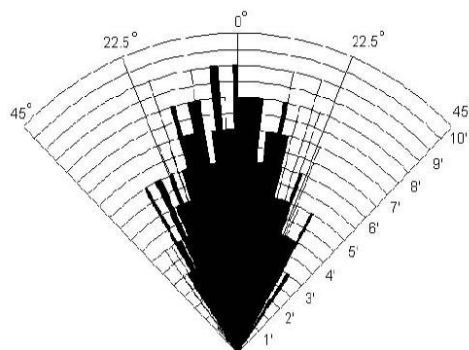
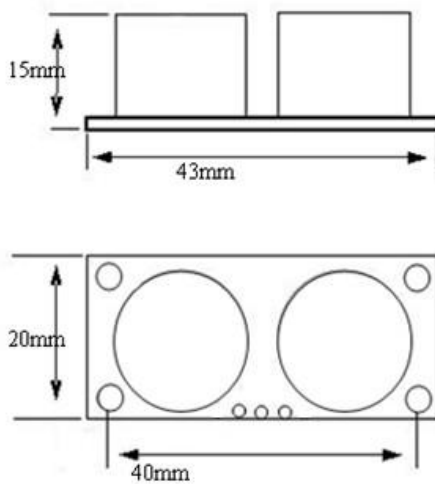
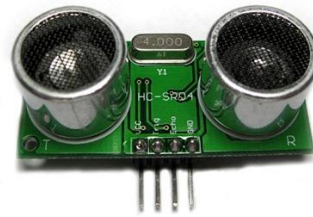

*Practical test of performance,
Best in 30 degree angle*

Sequence chart

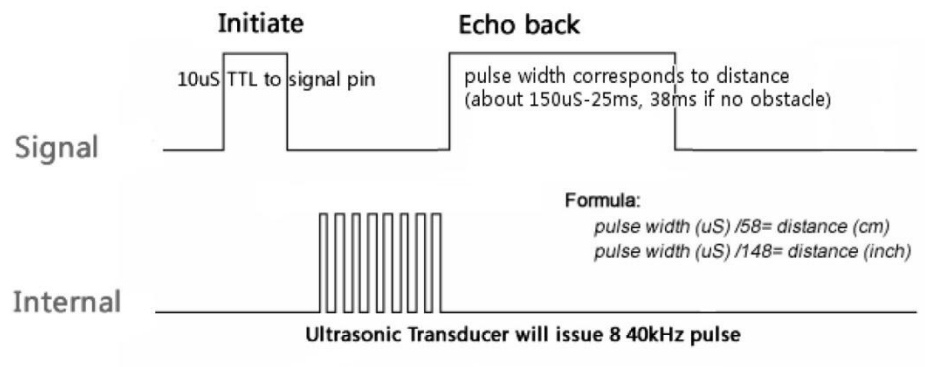

A short ultrasonic pulse is transmitted at the time 0, reflected by an object. The sensor receives this signal and converts it to an electric signal. The next pulse can be transmitted when the echo is faded away. This time period is called cycle period. The recommended cycle period should be no less than 50ms. If a 10µs width trigger pulse is sent to the signal pin, the Ultrasonic module will output eight 40kHz ultrasonic signal and detect the echo back. The measured distance is proportional to the echo pulse width and can be calculated by the formula above. If no obstacle is detected, the output pin will give a 38ms high level signal.

Library:

<http://iteadstudio.com/store/images/produce/Robot/HCSR04/Ultrasonic.rar>