

# HFD17

# SUBMINIATURE SIGNAL RELAY



File No.: E133481



File No.: R50431434



## Features

- 8A switching capability
- UL insulation system: Class F
- Epoxy sealed for automatic-wavesoldering and cleaning
- Standard PCB layout
- Product in accordance to IEC 60335-1 available

RoHS compliant

## CONTACT DATA

Contact arrangement	1A, 1C
Contact resistance <sup>1)</sup>	100mΩ max. (AgNi gold-plated specifications: 0.1A 6VDC, AgNi non gold-plated specifications and AgSnO <sub>2</sub> : 1A 6VDC)
Contact material	AgNi, AgSnO <sub>2</sub>
Contact rating (Res. load)	3A 30VDC 3A 250VAC
Max. switching voltage	250VAC / 220VDC
Max. switching current	8A(30VDC)
Max. switching power	750VA / 90W
Min. applicable load	5V 1mA (Suitable for AgNi gold-plated specifications)
Mechanical endurance	1 x 10 <sup>7</sup> OPS
Electrical endurance	1C type: 1 x 10 <sup>6</sup> OPS (NO: AgNi, 85°C, 1s on 9s off, HFD17-3A 30VDC, HFD17-1: 1A 30VDC) 5 x 10 <sup>4</sup> OPS (NO: AgNi, Room temp, 1s on 9s off, HFD17-3A 250VAC, HFD17-1: 1A 250VAC) 1A type: 2 x 10 <sup>6</sup> OPS (NO: AgNi, 85°C, 1s on 9s off, 3A 30VDC) 1 x 10 <sup>6</sup> OPS (NO: AgNi, 85°C, 1s on 9s off, 3A 250VAC)

Notes: 1) The data shown above are initial values.

2) Min. applicable load is reference value. Please perform the confirmation test with the actual load before production since reference value may change according to switching frequencies, environmental conditions and expected contact resistance and reliability.

## CHARACTERISTICS

Insulation resistance	1000MΩ (at 500VDC)
Dielectric strength	between coil & contacts 1500VAC 1min
	between open contacts 750VAC 1min
Operate time (at rated voltage.)	5ms max.
Release time (at rated voltage.)	5ms max.
Shock resistance	Functional NO: 294 m/s <sup>2</sup> NC: 147 m/s <sup>2</sup>
	Destructive 980 m/s <sup>2</sup>
Vibration resistance	Functional NO: 10Hz to 55Hz 3.3mm DA NC: 10Hz to 55Hz 2.5mm DA
	Destructive 10Hz to 55Hz 5mm DA
Surge withstand voltage	between open contacts (10/160μs) 1500V (FCC part 68)
	between coil & contacts (2/10μs) 2000V (Telecordia)
Humidity	5% ~ 85%RH
Ambient temperature	-40°C ~ 85°C
Termination	PCB(DIP)
Unit weight	Approx. 4g
Construction	Plastic sealed

Notes: 1) The data shown above are initial values;

2) UL insulation system: Class F.



HONGFA RELAY

ISO9001, IATF16949, ISO14001, OHSAS18001, IECQ QC 080000 CERTIFIED

2023 Rev. 1.00

## COIL

Coil power H: 150mW; Nil: 200mW

## COIL DATA

23°C

Standard type: (200mW)

Nominal Voltage VDC <sup>1)</sup>	Initial Pick-up Voltage VDC max.	Initial Drop-out Voltage VDC max.	Max. Voltage <sup>4)</sup> VDC	Coil Resistance x (1±10%)Ω
2.4	1.8	0.24	4.8	28.8
3	2.25	0.3	6.0	45.0
4.5	3.38	0.45	9.0	101.3
5	3.75	0.5	10	120
6	4.5	0.6	12	180
9	6.75	0.9	18	400
12	9.0	1.2	24	700
18	13.5	1.8	36	1620
24	18.0	2.4	48	2800

High sensitive type: (150mW)

Nominal Voltage VDC <sup>1)</sup>	Initial Pick-up Voltage VDC max.	Initial Drop-out Voltage VDC max.	Max. Voltage <sup>4)</sup> VDC	Coil Resistance x (1±10%)Ω
2.4	1.92	0.24	4.8	38.4
3	2.4	0.3	6.0	60.0
4.5	3.6	0.45	9.0	135
5	4.0	0.5	10	166.7
6	4.8	0.6	12	240
9	7.2	0.9	18	540
12	9.6	1.2	24	960
18	14.4	1.8	36	2160
24	19.2	2.4	48	3840

## COIL DATA

23°C

Notes: 1) The data shown above are initial values.

2) To supply rated step voltage to coil is the foundation of relay proper operation. Please make sure the applied voltage to the coil reach at rated values.

Please refer to the typical diagram below for single side stable relay. The "V\_coil" is the rated voltage. :

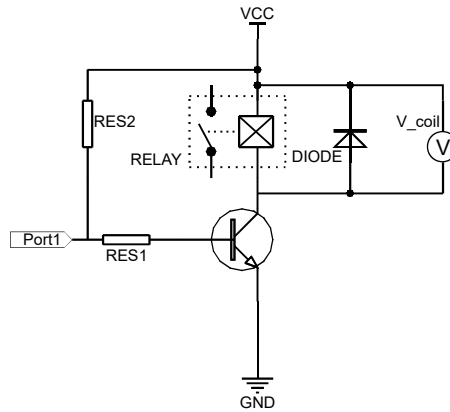

3) In case 5V of transistor drive circuit, it is recommended to use 4.5V type relay, and 3V to use 2.4V type relay.

4) For monostable relays, if you need to drop down voltage and hold mode after reliably operating, make sure that the effective value of holding voltage is not less than 60% of the rated voltage.

5) Maximum voltage refers to the maximum voltage which relay coil could endure in a short period of time.

6) When user's requirements can't be found in the above table, special order allowed.

7) During the relay pick-up or drop-out processes, there are stages of contact pressure change, contact vibration and unstable contact etc. When the voltage applied to coil is gradually changed, it will lengthen the unstable stage and affect relay endurance. To reduce this influence, please apply step voltage (switching circuit) to relay coil.

## SAFETY APPROVAL RATINGS

		HFD17	HFD17-1
UL/CUL	AgNi	3A 125VAC, 85°C 3A 250VAC, Room temp 3A 30VDC, 85°C	1A 125VAC, 85°C 1A 250VAC, Room temp 1A 30VDC, 85°C
	AgSnO <sub>2</sub>	3A 250VAC, 85°C 3A 30VDC, 85°C TV-1 125VAC, Room temp	1A 250VAC, 85°C 1A 30VDC, 85°C
TÜV	AgNi	3A 125VAC, 85°C 3A 250VAC, Room temp 3A 30VDC, 85°C	1A 125VAC, 85°C 1A 250VAC, Room temp 1A 30VDC, 85°C
	AgSnO <sub>2</sub>	3A 250VAC, 85°C 3A 30VDC, 85°C 1(1) 250VAC, Room temp	1A 250VAC, 85°C 1A 30VDC, 85°C 1(1) 250VAC, Room temp

Notes: 1) Only typical loads are listed above. Other load specifications can be available upon request.

## ORDERING INFORMATION

	<b>HFD17/</b>	<b>24</b>	<b>-Z</b>	<b>H</b>	<b>-3</b>	<b>N</b>	<b>(XXX)</b>
<b>Type</b>	HFD17:3A contact rating HFD17-1:1A contact rating						
<b>Coil voltage</b>	2.4, 3, 4.5, 5, 6, 9, 12, 18, 24 VDC						
<b>Contact arrangement</b>	<b>H: 1 Form A</b>			<b>Z: 1 Form C</b>			
<b>Coil power</b>	<b>H: High sensitive(150mW)</b>			<b>Nil: Standard(200mW)</b>			
<b>Contact material</b>	<b>3: AgNi</b>			<b>T: AgSnO<sub>2</sub></b>			
<b>Contact plating</b>	<b>Nil: gold plated(Only for AgNi type)</b>			<b>N: No gold plated</b>			
<b>Special code<sup>1)</sup></b>	<b>XXX: Customer special requirement</b>			<b>Nil: Standard</b>			

Notes: 1) The customer special requirement express as special code after evaluating by Hongfa.

2) For products that should meet the explosion-proof requirements of "IEC 60079 series", please note [Ex] after the specification while placing orders. Not all products have explosion-proof certification, so please contact us if necessary, in order to select the suitable products.

## OUTLINE DIMENSIONS, WIRING DIAGRAM AND PC BOARD LAYOUT

Unit: mm

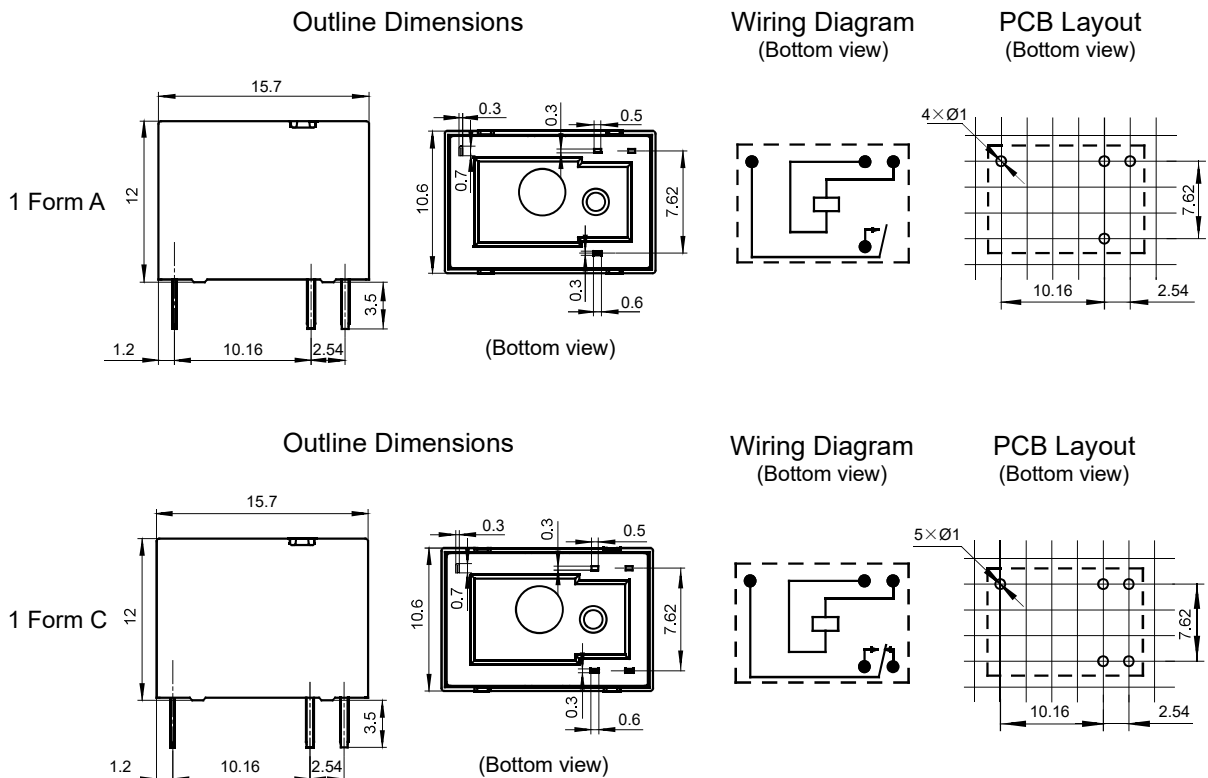

Remark: 1) The pin dimension of the product outline drawing is the size before tinning(it will become larger after tinning),and the mounting hole size is the recommended design size of the PCB board hole.The specific PCB board hole design size can be mapped and adjusted according to the actual product.

2) In case of no tolerance shown in outline dimension: outline dimension  $\leq 1\text{mm}$ , tolerance should be  $\pm 0.2\text{mm}$ ;  
outline dimension  $> 1\text{mm}$  and  $\leq 5\text{mm}$ , tolerance should be  $\pm 0.3\text{mm}$ ; outline dimension  $> 5\text{mm}$ , tolerance should be  $\pm 0.4\text{mm}$ .

3) The tolerance without indicating for PCB layout is always  $\pm 1\text{mm}$ .

4) The width of the gridding is 2.54mm.

## CHARACTERISTIC CURVES

### HFD17

MAXIMUM SWITCHING POWER

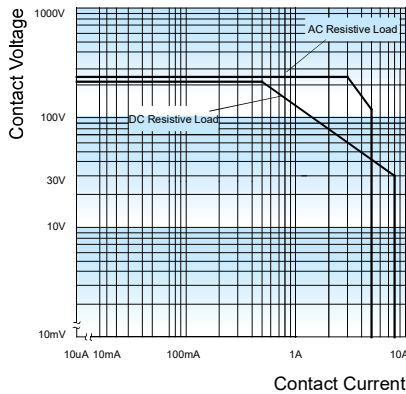

ENDURANCE CURVE

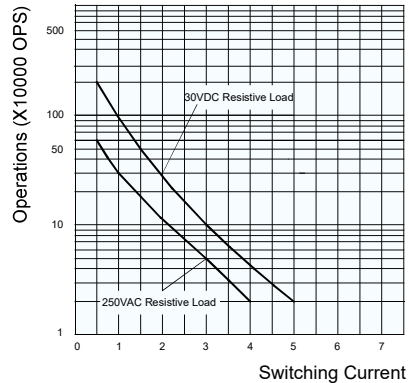

**Test conditions:**  
NO:AgNi, Resistive Load, 85°C, 1s on 9s off.

### HFD17-1

MAXIMUM SWITCHING POWER

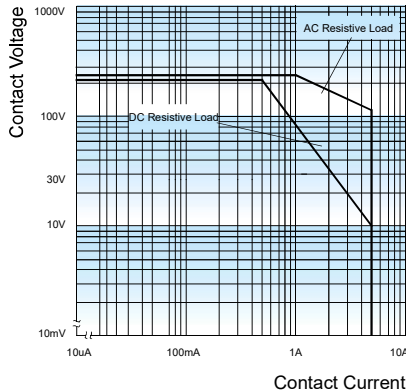

ENDURANCE CURVE

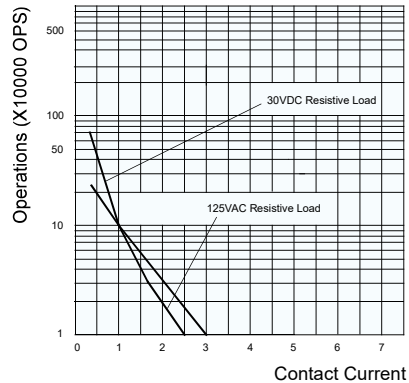

**Test conditions:**  
NO:AgNi, Resistive Load, 85°C, 1s on 9s off.

#### Notice

- 1) To avoid using relays under strong magnetic field which will change the parameters of relays such as pick-up voltage and drop-out voltage.
- 2) Energizing coil with rated voltage is basic for normal operation of a relay, please make sure the energized voltage to relay coil have reached the rated voltage. Regarding latching relay, in order to maintain the "set" or "reset" status, impulse width of the rated voltage applied to coil should be more than 5 times of "set" or "reset" time.
- 3) For a monosteady state relay, after the relay is reliably operated, if it needs to be kept under pressure, make sure that the effective value of the voltage is not less than 60% of the rated voltage;
- 4) The relay may be damaged because of falling or when shocking conditions exceed the requirement.
- 5) Please use wave soldering or manual soldering for straight-in relay. If you need reflow welding, please confirm the feasibility with us.
- 6) Contact is recommended for suitable condition and specifications if water cleaning or surface process is involved in assembling relays on PCB.
- 7) Plastic sealed type is recommended for an environment with noxious gas such as H<sub>2</sub>S, SO<sub>2</sub> and NO<sub>2</sub>, etc., and/or when load current is low, and/or the PCB boards need to be washed after relays are soldered.
- 8) Regarding the plastic sealed relay, we should leave it cooling naturally until below 40°C after welding, then clean it and deal with coating, remarkably the temperature of solvents should also be controlled below 40°C. Please avoid cleaning the relay by ultrasonic, avoid using the solvents like gasoline, Freon, and so on, which would affect the configuration of relay or influence the environment.
- 9) When applied with continuous current, the heat from relay coil will age its isolation. Thus, please do not ground connected the coil to reduce electrical erosion if possible. And please provide protection circuit to avoid broken wire and losses.
- 10) Please make sure that there are no silicon-based substances (such as silicon rubber, silicone oil, silicon-based coating agents, silicon fillers, etc.) around the relay, because it will generate silicon-containing volatile gas, which may cause poor contact in case of silicon-containing volatile gas sticking on contact.
- 11) About preferable condition of operation, storage and transportation, please refer to "Explanation to terminology and guidelines of relay".
- 12) During the relay pick-up or drop-out processes, there are stages of contact pressure change, contact vibration and unstable contact etc. When the voltage applied to coil is gradually changed, it will lengthen the unstable stage and affect relay endurance. To reduce this influence, please apply step voltage (switching circuit) to relay coil.

#### Disclaimer

The specification is for reference only. See to "Terminology and Guidelines" for more information. Specifications subject to change without notice. We could not evaluate all the performance and all the parameters for every possible application. Thus the user should be in a right position to choose the suitable product for their own application. If there is any query, please contact Hongfa for the technical service. However, it is the user's responsibility to determine which product should be used only.

© Xiamen Hongfa Electroacoustic Co., Ltd. All rights of Hongfa are reserved.