

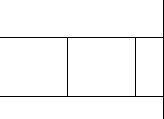
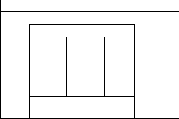
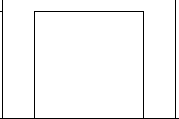
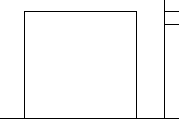
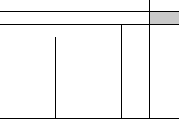
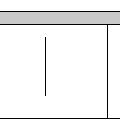

**AC Output Receptacles (optional)**

					
TYPE-1	TYPE-2	TYPE-3	TYPE-4	TYPE-5	TYPE-6
JAPAN	USA	EUROPE	UNIVERSAL	AUSTRALIA	U.K

**Mechanical Specification**

Unit:mm

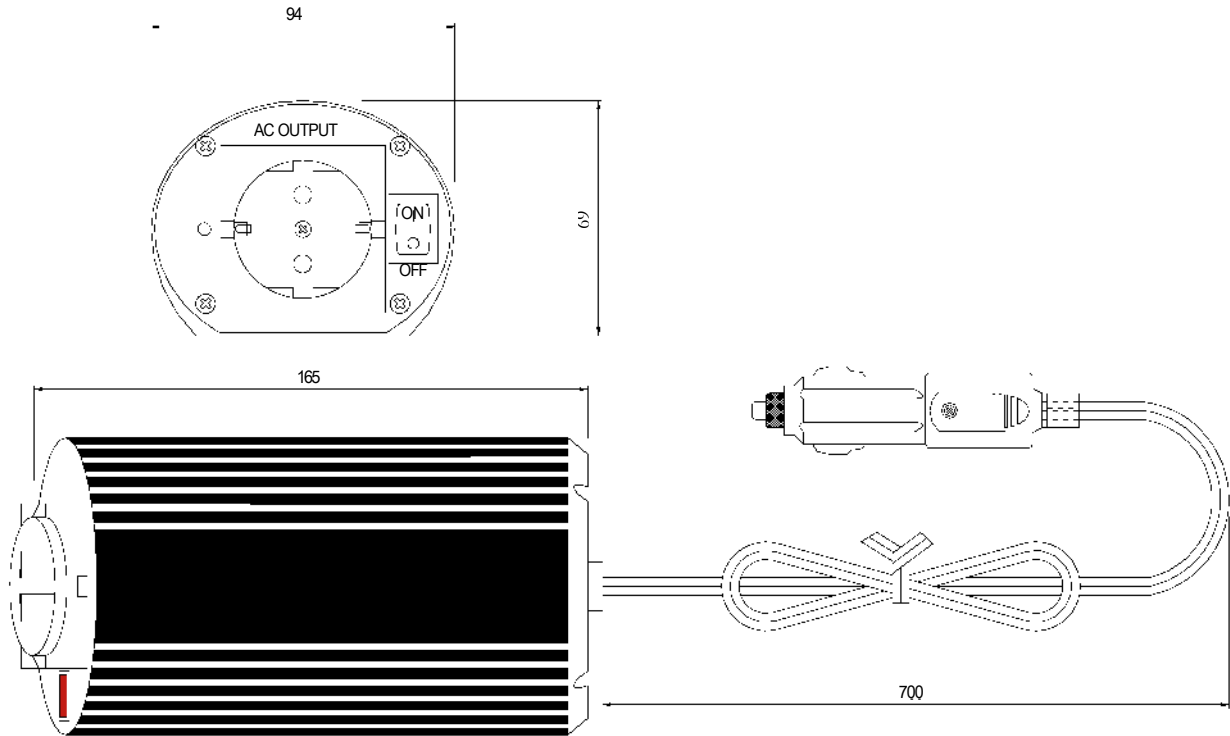

**AC Waveform Modified Sine Wave**

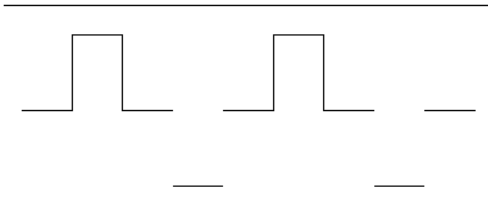

**CAUTION**

Always place the inverter in an environment which s

- (A) Well ventilated
- (B) Not exposed to direct sunlight or heat source
- (C) Out of reach from children
- (D) Away from water/moisture oil or grease
- (E) Away from any flammable substance

**Derating Curve**

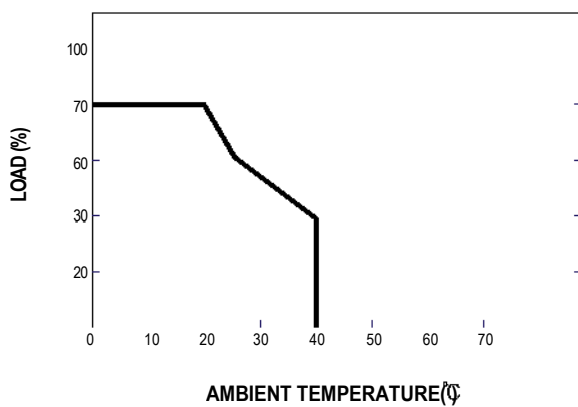

**Output Loading & Duty**

