

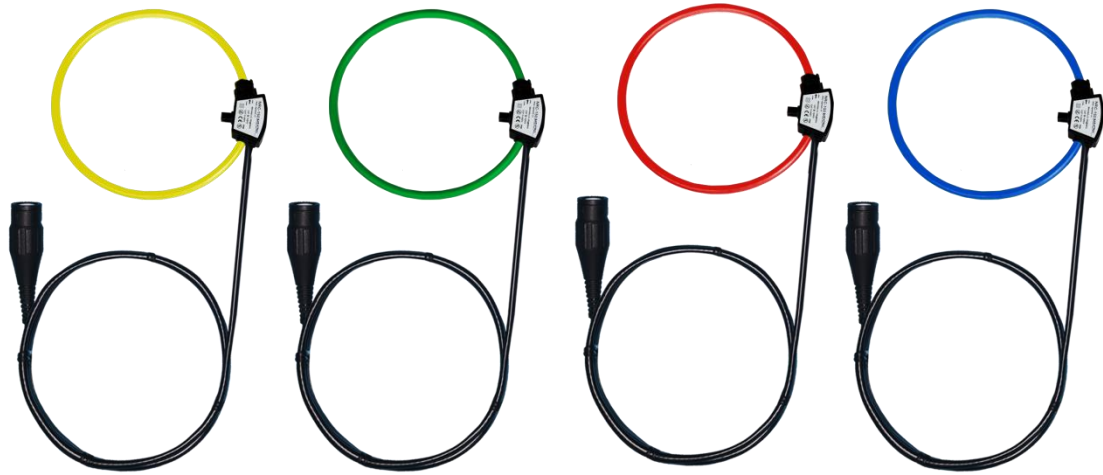

Mi550 Handheld Three phase Power quality analyzer Manual

V1.0.220713



Revision history

Version	Date	Modification
V1.0	2022/07/13	Create documents

Contents

1 Product description	1
1.1 General parameters	1
1.2 Measurement parameters	2
1.3 Parameter accuracy	3
1.4 Record storage	4
2 Product usage	5
2.1 Product Appearance	5
2.2 Key function	5
2.3 Startup and shutdown	6
2.4 Keyboard locking and unlocking	7
3 Wiring instructions	8
3.1 Wiring Requirements	8
3.2 Wiring methods	9
3.2.1 3P4W_4CT	9
3.2.2 3P4W_3CT	9
3.2.3 3P3W_3CT	10
3.2.4 3P3W_2CT	11
3.2.5 1P2W	11
4 Record	12
4.1 Data recorder	12
4.2 Event record	13
4.3 Waveform recording	14
4.4 Record management	15
5 Operation and interface display	15
5.1 Function introduction	15
5.2 Screen introduction	17
5.3 Parameter setting interface	18
5.3.1 Introduction	18
5.3.2 Key operation	18
5.4 Power grid parameter setting	19
5.4.1 Wiring mode setting	19
5.4.2 Power grid frequency configuration	20
5.4.3 Nominal voltage setting	20
5.4.4 Current transformer setting	21
5.4.5 Voltage transformer setting	22
5.4.6 Zero drift suppression setting	22
5.4.7 Harmonic calculation threshold setting	23
5.4.8 Event parameter setting	24
5.4.9 Demand setting	25
5.4.10 CO2 Emission factor setting	26
5.5 System parameter setting	26
5.5.1 System information	27

5.5.2 Communication settings	27
5.5.3 Clock setting	29
5.5.4 Screen setting	29
5.5.5 Keyboard setting	30
5.5.6 Language setting	31
5.6 User parameter setting	31
5.6.1 User information setting	32
5.6.2 Phase sequence name setting	33
5.6.3 Phase sequence color setting	34
5.7 Reset	35
5.8 Measurement interface	36
5.8.1 Introduction	36
5.8.2 Key operation	37
5.9 Voltage and current	37
5.10 Power	37
5.11 Energy	38
5.12 Harmonic	38
5.13 Waveform	40
5.14 Phasor	41
5.15 Unbalance	42
5.16 Demand	42
5.17 Recording interface	43
5.17.1 Introduction	43
5.17.2 Key operation	44
5.18 Data recorder	44
5.19 Waveform Recorder	45
5.20 Record management	47
5.21 Storage capacity	49
6 Modbus Communication	50
6.1 Modbus-TCP/IP data frame	51
6.2 Modbus-TCP/IP Function code operation instructions	52
6.2.1 Function code (0x03=3) operation instructions	52
6.2.2 Function code (0x10=16) operating instructions	54
6.2.3 Error response	56
7 List of configuration instructions	56
8 Register list	63
8.1 Modbus Register list	64
9 Operation interface topology	77
9.1 Setup	77
9.2 Measure	78
9.3 Record	79

1 Product description

Mi550 handheld three phase power quality analyzer, externally connected with open type Rogowski coil or voltage type CT, it can realize none dismantling wire test, simplify test steps, save construction cost, and is more convenient for engineering test as well as the inspection and maintenance of distribution system.

- ◆ Support systems of single-phase and three-phase. It can measure multiple electrical parameters such as current, voltage, power factor, power, energy, and power quality parameters including harmonic, unbalance degree, voltage swell and voltage dip, etc.
- ◆ In addition to the measurement function, Mi550 is equipped with various records, such as waveform records and programmable interval measurement value records. To store and record data, it is internally embedded 32 GB memory card.
- ◆ With standard configuration of RJ45 Ethernet communication interface, through standard Modbus TCP protocol, it is compatible with various configuration systems and could transmit the electrical parameters collected by the front end to the system data center in real time.

1.1 General parameters

Table 1-1 General parameters

Product name	
Model No.	Mi550
Type	Handheld Three phase power quality analyzer
Application field	
Application field	Power analysis, Power measurement, Power quality analysis
Wiring mode	
Wiring system	3P4W_4CT 3P4W_3CT 3P3W_3CT 3P3W_2CT 1P2w
Current sensor	Rogowski coil Voltage-output current clamp
Voltage access	Direct access Connected through voltage transformer
Storage	
Type	TF card
Capacity	32GB
Data export	U disk export (U disk file is FAT32 system)
Communication	
Interface	RJ45- Ethernet
Protocol	Modbus-TCP
Power Supply	
Adapter input	5VDC, 2A
Battery	Rechargeable lithium battery, specification 18650, 2 pcs, capacity about 4000mAh

Battery purely working time	≥6h
Battery charging time (off state)	≤5h
Power saving mode	The brightness of the screen backlight is adjustable. The automatic screen off time is adjustable.
Display	
Size	3.97 inch
Type	IPS display
Resolution ratio	480*800
Machinery	
Dimension	215*130*60mm
Weight	850g
Environment	
Working environment	Temperature-20℃~+55℃, Humidity below 90% RH
Storage environment	Temperature-40℃~+70℃, Humidity below 95% RH (non-condensing)
Altitude	≤2km
Measurement category	CAT III 600V
IP code	IP30

1.2 Measurement parameters

Table 1-2 Measurement parameters

Real-time measurement data	
Voltage	Phase voltage: Phase ABC N phase to ground voltage Line voltage: UAB, UBC, UCA Voltage peak coefficient: Phase ABC Voltage peak: Phase ABC
Current	Phase current: Phase ABCN Current peak coefficient: Phase ABC K Factor: Phase ABC
Frequency	Line frequency
Power	Active power: Phase ABC and total Reactive power: Phase ABC and total Apparent power: Phase ABC and total
Power factor	Phase ABC and total
Fundamental harmonic power factor	Phase ABC and total
Electrical energy	Active Energy: Phase ABC and total (import / export) Reactive energy: Phase ABC and total (import / export) Apparent Energy: Phase ABC and total CO2 emissions
Harmonic measurement data	

Voltage harmonics	THD (Total harmonic percentage), TOHD (Odd total harmonic percentage), TEHD (Even total harmonic percentage), phase ABC 1-50 th harmonic percentage, phase ABC 1-50 th harmonic voltage value
Current harmonics	THD (Total harmonic percentage), TOHD (Odd total harmonic percentage), TEHD (Even total harmonic percentage), phase ABC 1-50 th harmonic percentage, phase ABC 1-50 th harmonic current value
Waveform	
Voltage waveform	Phase ABC voltage waveform or UAB, UBC, UCA line voltage waveform
Current waveform	Phase ABC current waveform
Phase angle	
Voltage phase angle	Phase ABC
Current phase angle	Phase ABC
Phase angle between voltage and current	Phase ABC
Unbalance	
Unbalance	Voltage unbalance, current unbalance
Demand	
Power demand and peak demand	Phase ABC active power and total power, phase ABC reactive power and total power, phase ABC apparent power and total power
Current demand and peak demand	Phase ABC

1.3 Parameter accuracy

Table 1-3 Parameter accuracy

Parameter	Type	Description
Voltage	Channel input voltage range	0-600VAC
	Measurement range	0-600VAC
	Measurement accuracy	0.2%
Current	Channel input voltage range	0-420mVAC
	Measurement range	Different current sensors have different measuring ranges
	Measurement accuracy	0.2%+ Accuracy of current sensor
Frequency	Measurement range	45Hz-65Hz
	Measurement accuracy	±0.001Hz
Power factor	Measurement range	-1+1
	Measurement accuracy	±0.005
Power	Active power accuracy	0.5%
	Reactive power accuracy	1%

	Apparent power accuracy	0.5%
Energy	Active energy accuracy	0.5%
	Reactive energy accuracy	1%
	Apparent energy accuracy	0.5%

1.4 Record storage

Table 1-4 Record storage

Data record	
Record name	Settable
Record start time	Settable
Record duration	Selectable
Recording interval	Settable
Basic data record	Phase voltage Line voltage Current Frequency Power factor Fundamental harmonic power factor Power (Active, Reactive, Apparent) Active Energy (Import energy, Export energy) Reactive energy (Import energy, Export energy) Apparent Energy Voltage harmonics (Total harmonic, odd total harmonic, even total harmonic) Current harmonics (Total harmonic, odd total harmonic, even total harmonic) Phase voltage peak Peak factor of phase voltage Current crest factor Current K factor Voltage unbalance (negative sequence, zero sequence) Current unbalance (negative sequence, zero sequence) Angle (phase voltage angle, phase current angle, angle between voltages, angle between currents, angle between voltages and currents) Max min (Phase voltage, Line voltage, Current, Frequency, Power factor, Fundamental harmonic power factor, Active power, Reactive power, Apparent power) Demand (Current, Active power, Reactive power, Apparent power) Peak Demand (Current, Active power, Reactive power, Apparent power)
Voltage harmonic data record	Voltage harmonics (Total harmonic distortion THD, Odd total harmonic TOHD, Even total harmonic TEHD, 1-50 th Harmonic percentage and voltage value)
Current harmonic data record	Current harmonics (total harmonic distortion THD, Odd total harmonic TOHD, Even total harmonic TEHD, 1-50 th Harmonic percentage and current value)
Data storage format	CSV

Event record ^[1]	
Recorded data	Event type Start time Duration Amplitude value
Data storage format	CSV
Waveform recording	
Record name	Settable
Record the start time	Settable
Record the duration	Settable
Sampling rate	Settable
Logged data	Phase ABC voltage waveform Phase ABC current waveform
Data storage format	CSV

2 Product usage

2.1 Product Appearance

As shown in Figure 2-1, the analyzer has a wrist strap on the side for easy one-handed holding. If you need to place it on a flat tabletop, you can open the elevation stand behind the analyzer. Open the dust cover on the right side of the analyzer to see the power socket, Ethernet data transmission interface, and USB insertion port. The analyzer has two built-in 18650 rechargeable lithium batteries, and the back cover of the analyzer can be opened for replacement.











Figure 2- 1 Product appearance

2.2 Key function

The front of the analyzer contains 13 buttons, and the key functions are divided into the following parts, as shown in the following figure:

^[1] Event recording can only be performed when data recording is enabled.

Table 2- 1 Key function

Key	Name	Function
	Power key	Power On and off , keyboard lock, unlock function
	Arrow keys	Used for page switching and parameter selection 
	Measure key	Real-time measurement data, harmonic histogram, Phasor, waveform display
	Set key	Set the analyzer parameters
	Record key	Data record, Event record, Waveform record
	Confirmation key	Confirmation of selection and operation
	Function keys	Functional extensions for different pages

2.3 Startup and shutdown

In the shutdown state, press and hold the power button  for 3 seconds to power on the system, and enter the boot interface as shown in Figure 2-2.

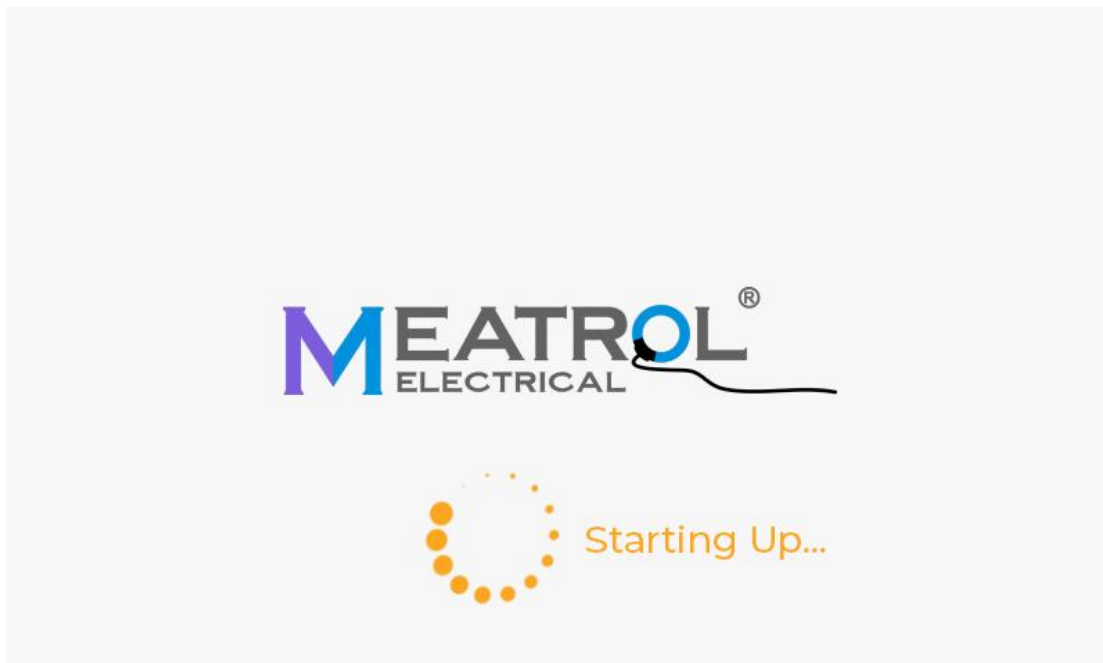

Figure 2-2 The boot interface

In the power-on state, press the power button  for 3 seconds to enter the shutdown selection

interface as shown in Figure 2-3, you can choose to shut down, restart or cancel.

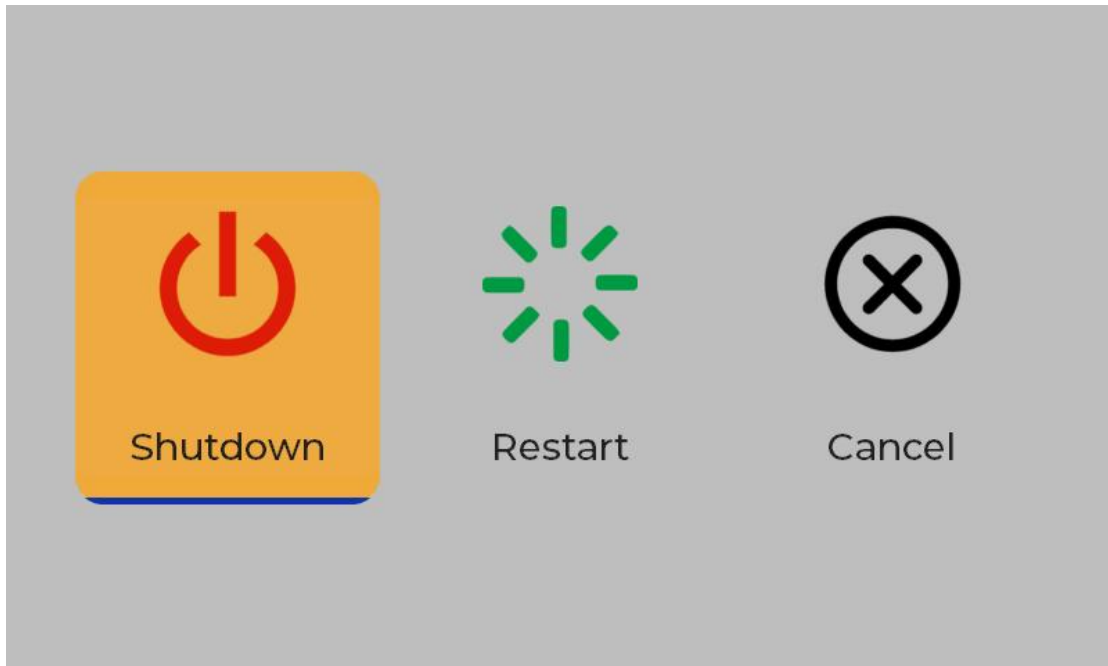



Figure 2-3 Shutdown interface

2.4 Keyboard locking and unlocking

When the keyboard is not locked, short press the power key , the keyboard will be locked, and the keyboard operation is invalid, as shown in Figure 2-4.

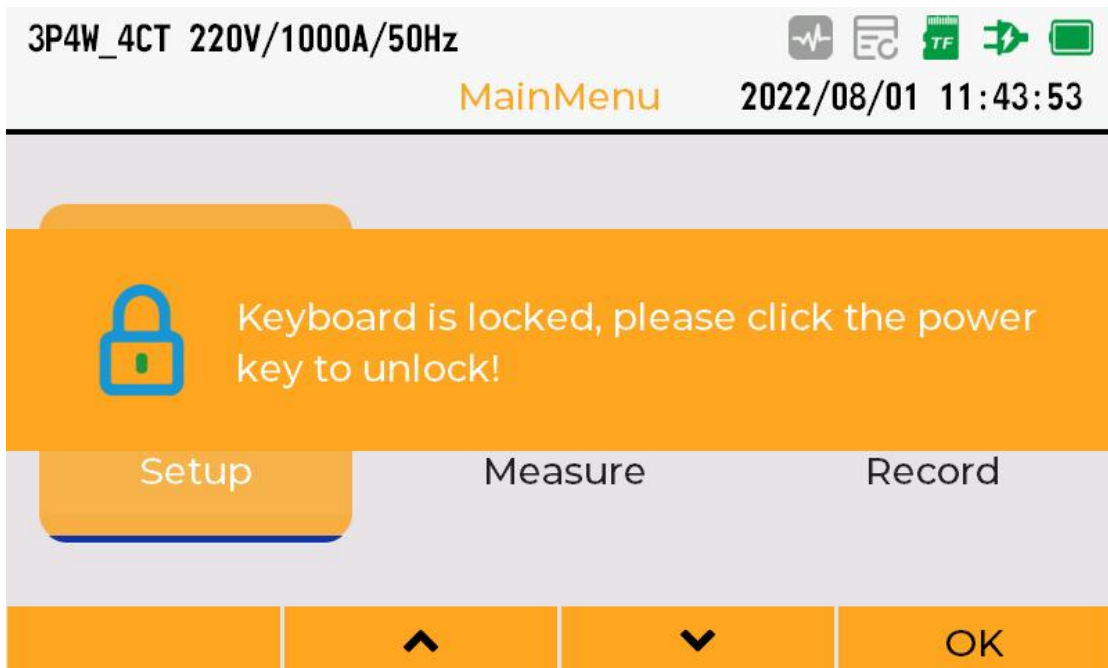



Figure 2-4 Keyboard locked

When the keyboard is locked, short press the power key , the keyboard will be unlocked, and the keyboard operation is effective, as shown in Figure 2-5.

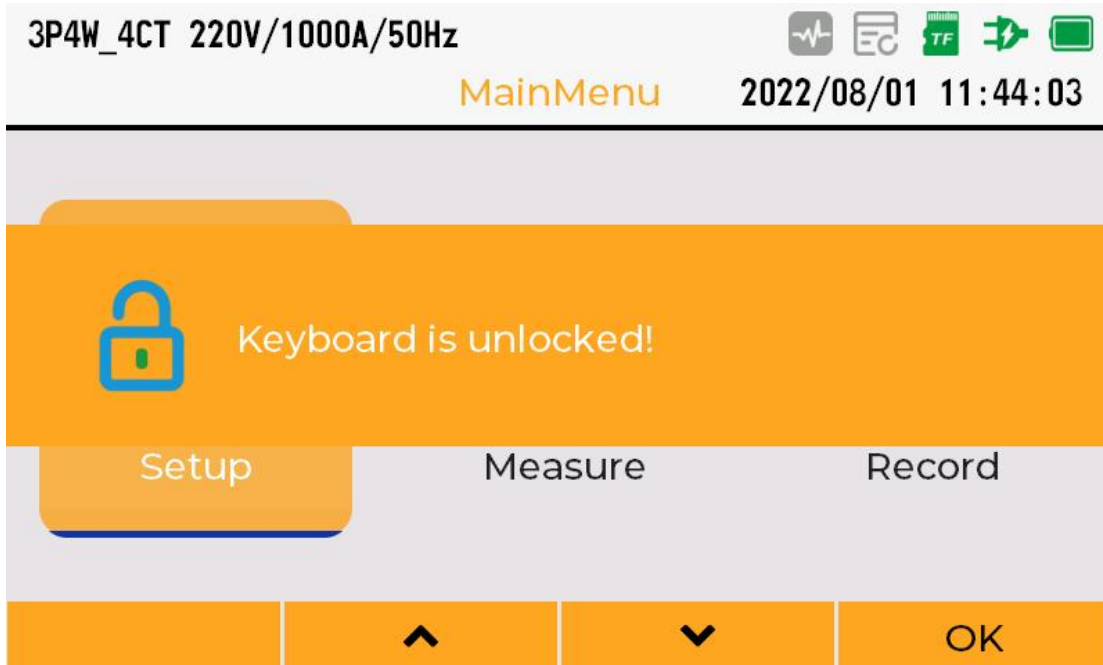

Figure 2-5 Keyboard unlocking

3 Wiring instructions

3.1 Wiring Requirements

At the top of the analyzer there are 4 voltage channels, 1 ground channel, and 4 current channels; 4mm banana plug interface is used for voltage and grounding channels, and BNC plug interface is used for current channels.

Tips

- Operators must wear safety protective equipment;
- To ensure safety, please disconnect the power supply system before wiring;
- Before starting the measurement, the analyzer must be set up according to the requirements of the power system line voltage, frequency and wiring configuration to be measured;
- Wiring requirements of current clamp: hang the current clamp on the wires of A, B, C and N, and note that the arrow is marked on the clamp to indicate the current flow direction, that is, to point to the direction of the load. For single-phase measurement, please use port A;
- Voltage clamp wiring requirements: starting from the grounding wire GND, clamp the voltage clamp on the corresponding line in the order of GND, N, A, B and C. For single-phase measurement, please use A, GND, N. note that phase A is the reference phase for all measurements.

3.2 Wiring methods

The analyzer supports 5 kinds of wiring methods, before connecting the measurement wires, please correctly configure the wiring method of the analyzer, see 55.45.4.1 for the detailed process. The comparison of wiring methods is shown in the table below:

Table 3-1 Comparison of three-phase four-wire wiring methods

Wiring method	N-phase current acquisition method
3P4W_4CT	Acquired via sensor
3P4W_3CT	Obtained by calculation

Table 3-2 Comparison of three-phase three-wire wiring methods

Wiring method	Phase B current acquisition method
3P3W_3CT	Acquired via sensor
3P3W_2CT	Obtained by calculation

3.2.1 3P4W_4CT

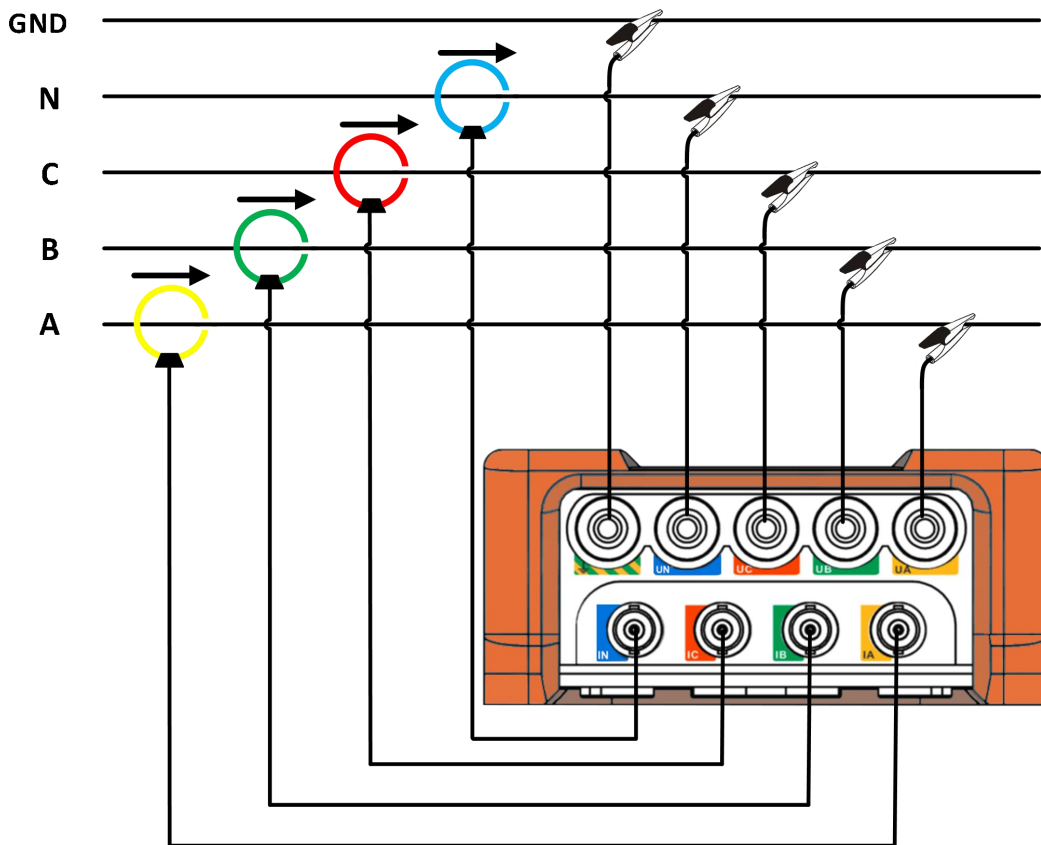

Figure 3- 1 3P4W_4CT

3.2.2 3P4W_3CT

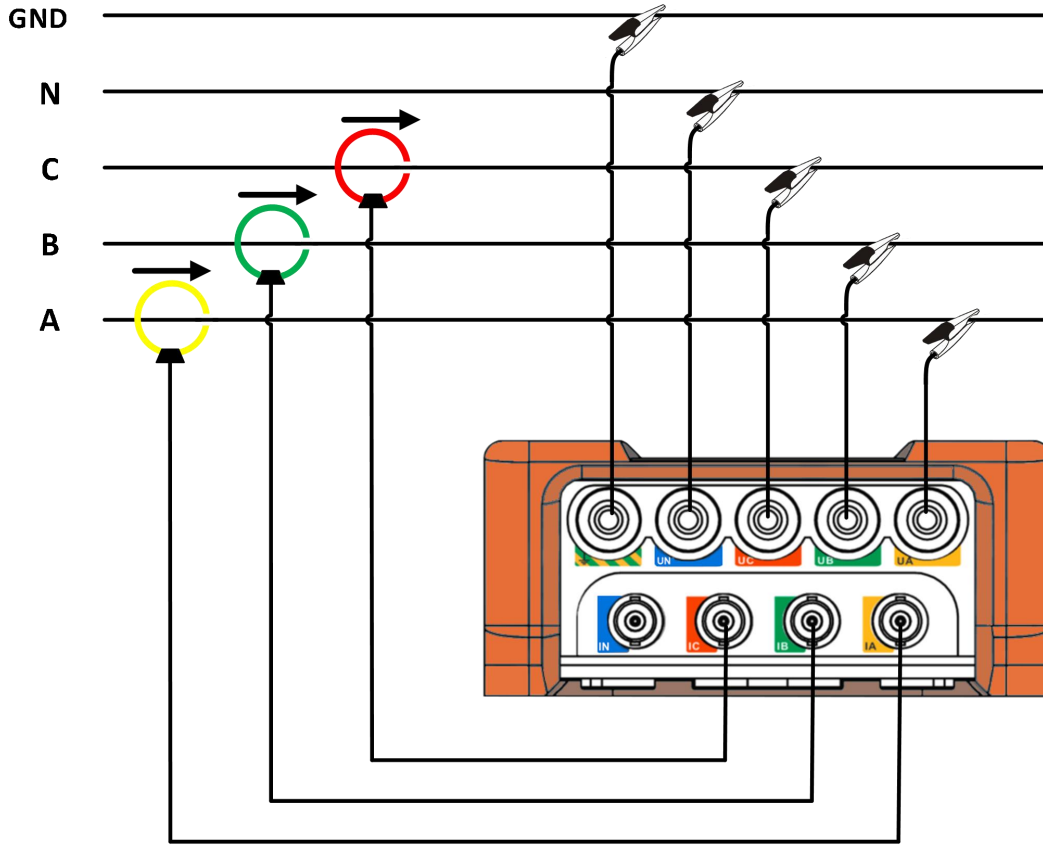

Figure 3-2 3P4W_3CT

3.2.3 3P3W_3CT

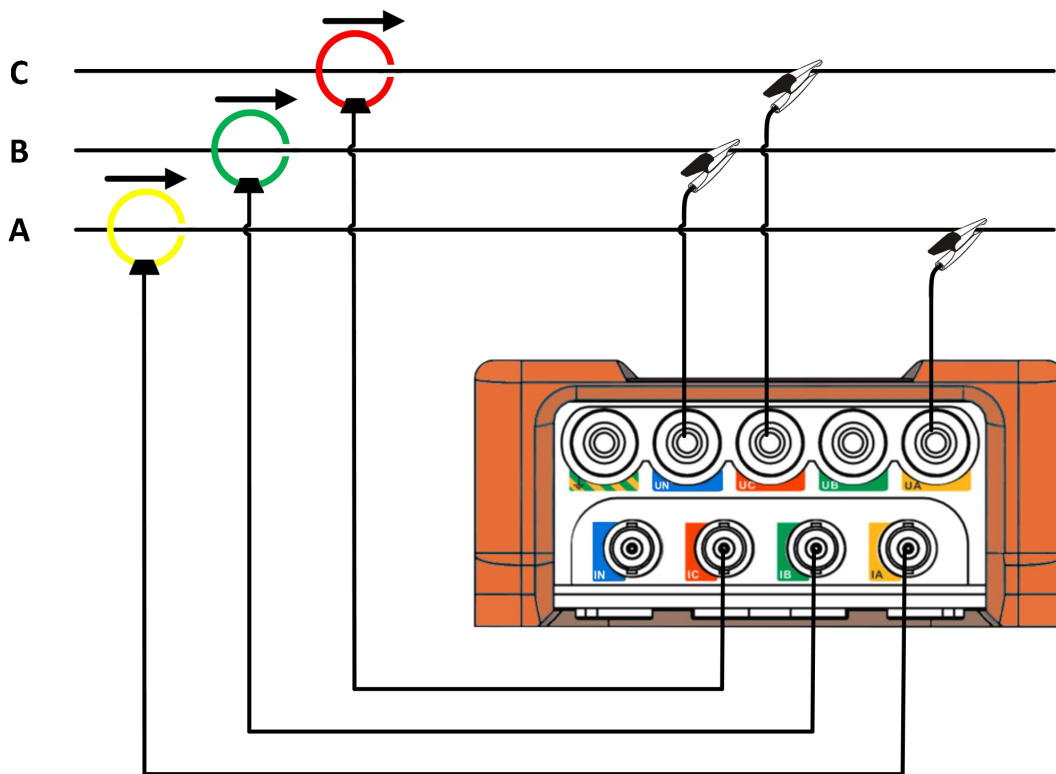

Figure 3-3 3P3W_3CT

3.2.4 3P3W_2CT

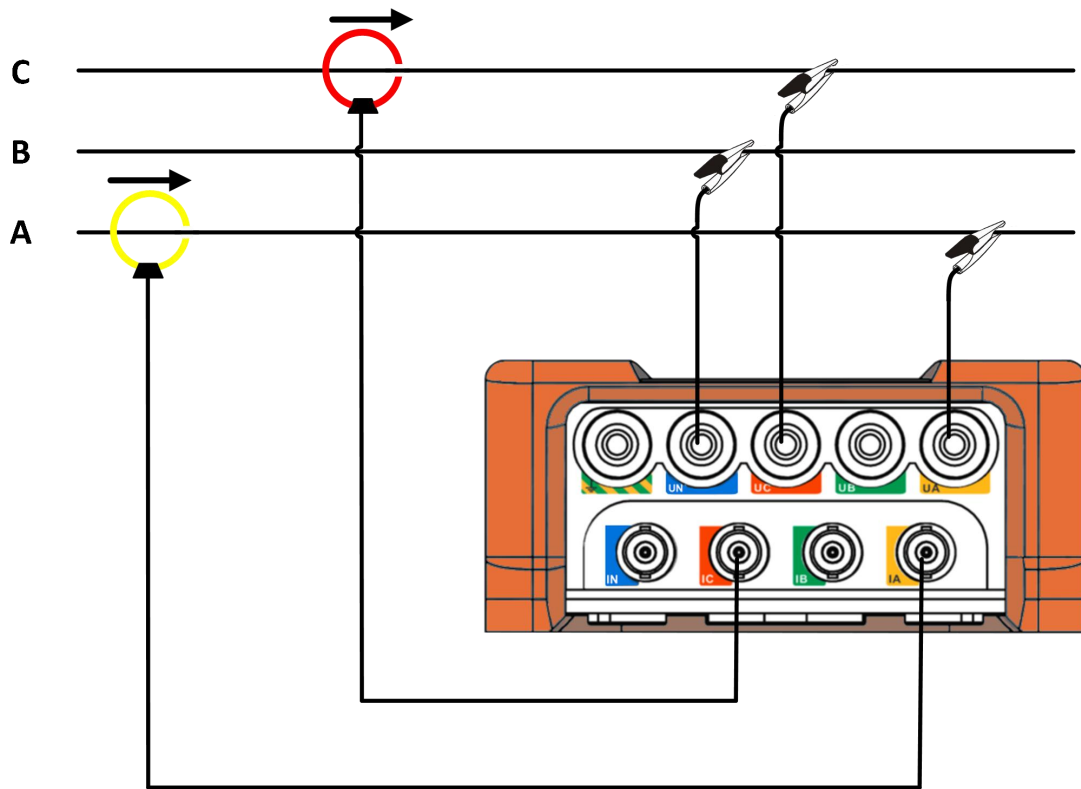

Figure 3-4 3P3W_2CT

3.2.5 1P2W

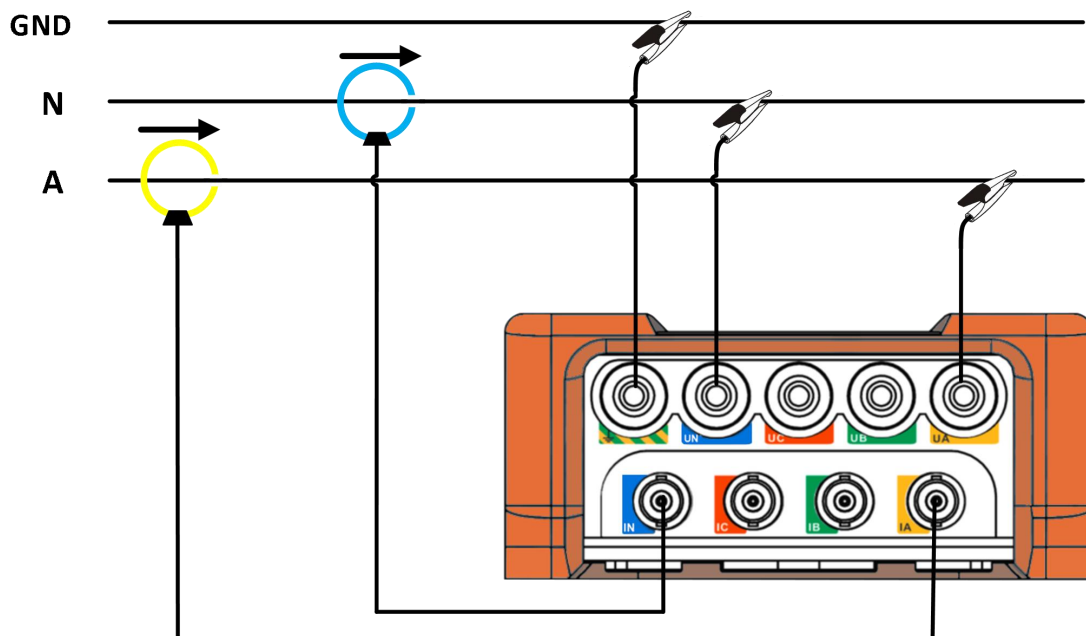

Figure 3-5 1P2W

4 Record

- ◆ There is 32GB storage space inside the analyzer, which is used to store data records, event records and waveform records.
- ◆ Data records include basic data records, voltage harmonic records and current harmonic records, and the file storage format is CSV format.
- ◆ The event record includes event type, start time, duration and amplitude value, and the file storage format is CSV format.
- ◆ Waveform record includes real-time waveform data of three-phase voltage and three-phase current, and the file storage format is CSV format.
- ◆ All record files can be exported through USB flash disk, and all record files can be deleted through the operation interface.

4.1 Data recorder

Data records include basic data records, voltage harmonic records and current harmonic records, and the file storage format is CSV format.

The record name, start time, duration and recording interval could be set.

When get to the set time, the data starts to be recorded and stops automatically after the recording is completed..

3P4W_4CT 220V/1000A/50Hz

<Record Data Recorder 2022/07/25 08:58:13

Record Name: DataRecord1

Start Time: 2022/07/25 08:58:10

Duration 1 h

Interval(s): 0005

Start

Figure 4- 1 Data recorder

4.2 Event record

Warning

Event recording can only be performed when data recording is enabled!

Events include voltage swell, voltage dip, voltage interruptions, frequency events, unbalance events, harmonic events, etc.

The event record will record the event type, start time, duration and amplitude value. The file storage format is CSV format.

Voltage swell and dip are rapid changes of normal voltage. The variation range can be as high as 10 to 100 times of the voltage. According to the definition of EN61000-4-30, its duration ranges from half a cycle to several seconds. The analyzer can set the nominal voltage as the reference value.

The voltage rises during the swell. In a three-phase system, when the voltage of one or more phases rises to the swell threshold, the swell begins; When the voltage of all phases is equal to or less than the swell threshold minus hysteresis, the swell stops. The trigger conditions of voltage swell are threshold and hysteresis. The swell is characterized by its duration, amplitude and occurrence time. As shown in Figure 4-2:

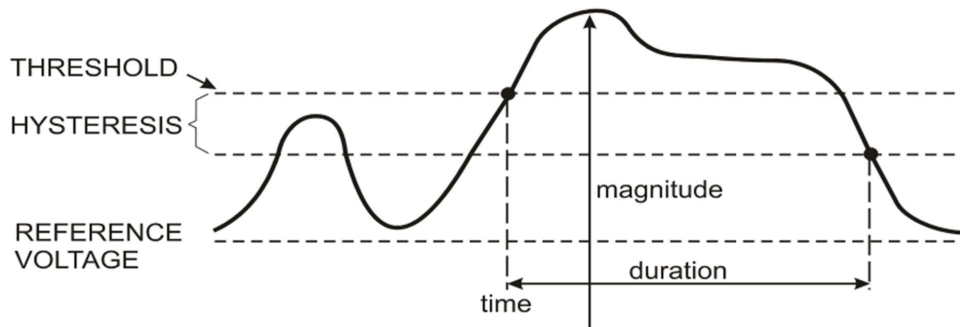

Figure 4-2 Voltage swell

The voltage drops during the dip. In a three-phase system, when the voltage of one or more phases drops to the dip threshold, the dip begins; When the voltage of all phases is equal to or greater than the dip threshold plus hysteresis, the dip stops. The trigger conditions of dip are threshold and hysteresis. The dip is characterized by its duration, amplitude and occurrence time. As shown in Figure 4-3.

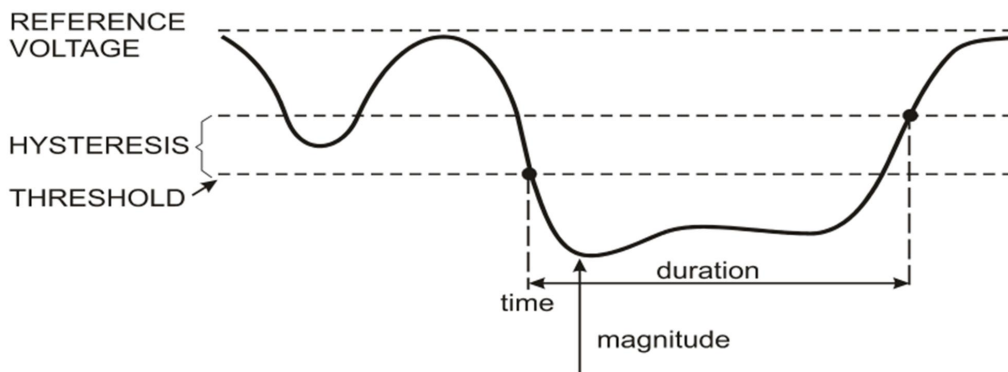

Figure 4-3 Voltage dip

During the interruption, the voltage drops far below the nominal voltage value. In a three-phase system, when the voltage of one or more phases drops to the interruption threshold, the interruption begins;

When the voltage of all phases is equal to or greater than the interruption threshold plus hysteresis, the interruption stops. The trigger conditions of interrupt are threshold and hysteresis. Interruption is characterized by duration, amplitude and occurrence time. As shown in Figure 4-4.

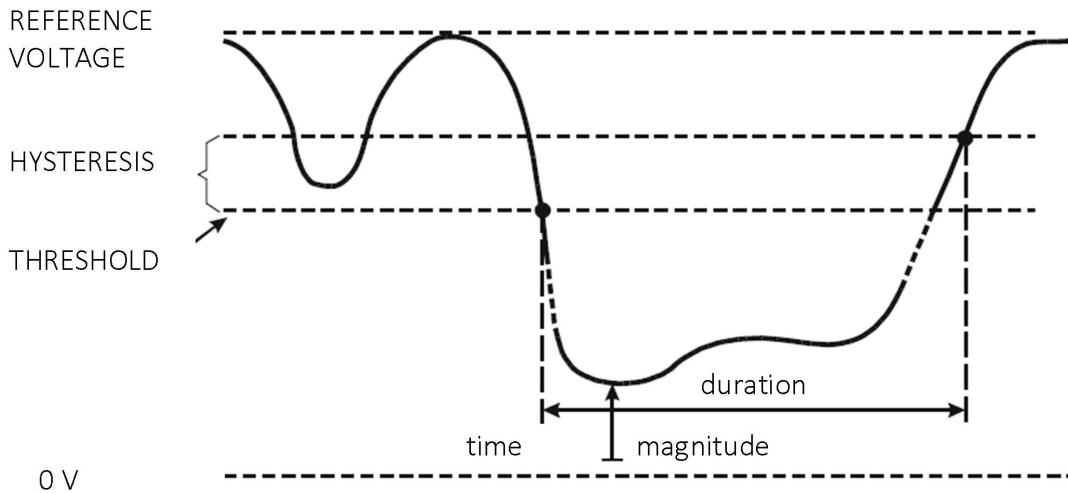

Figure 4-4 Voltage interruption

4.3 Waveform recording

- ◆ Waveform record includes real-time waveform data of three-phase voltage and three-phase current, and the file storage format is CSV format.
- ◆ Record name, start time, sampling rate and duration can be set.
- ◆ When get to the set time, the waveform starts to record and stops automatically after the recording is completed.

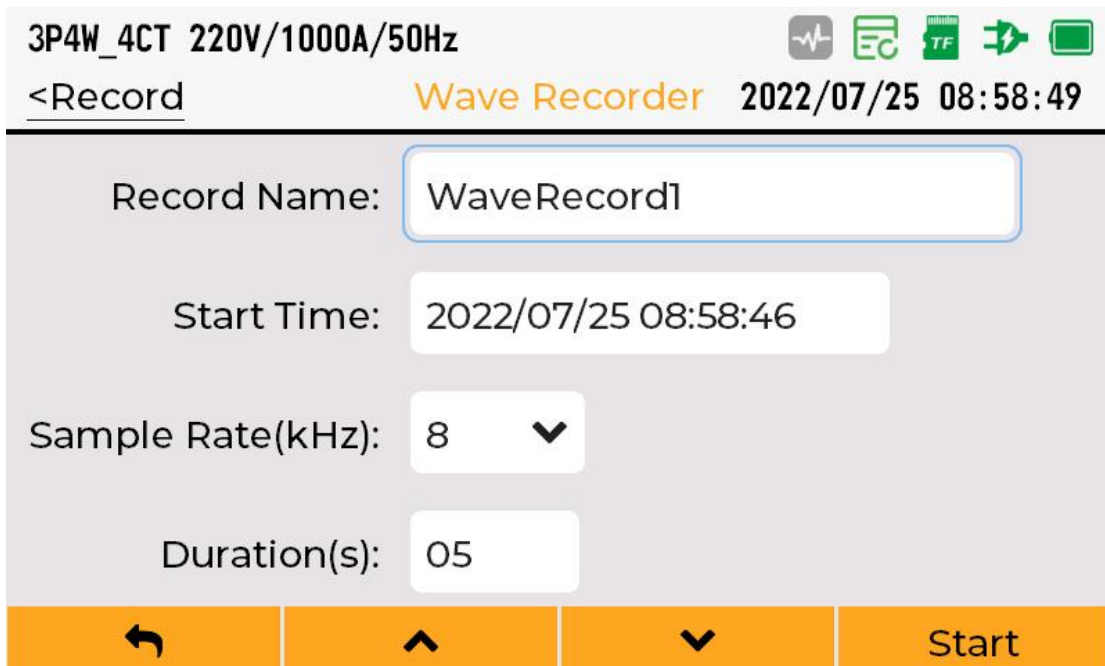

Figure 4-5 Waveform Recorder

4.4 Record management

The records stored by the analyzer can be deleted and exported through U disk (the file system must be FAT32).

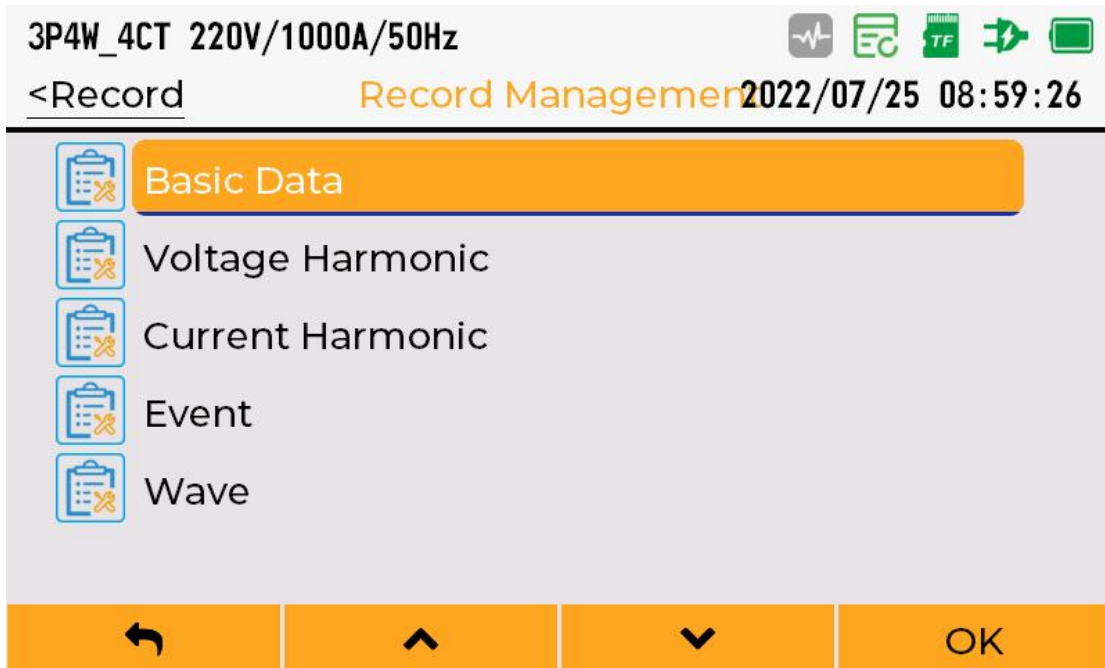

Figure 4-6 Record management

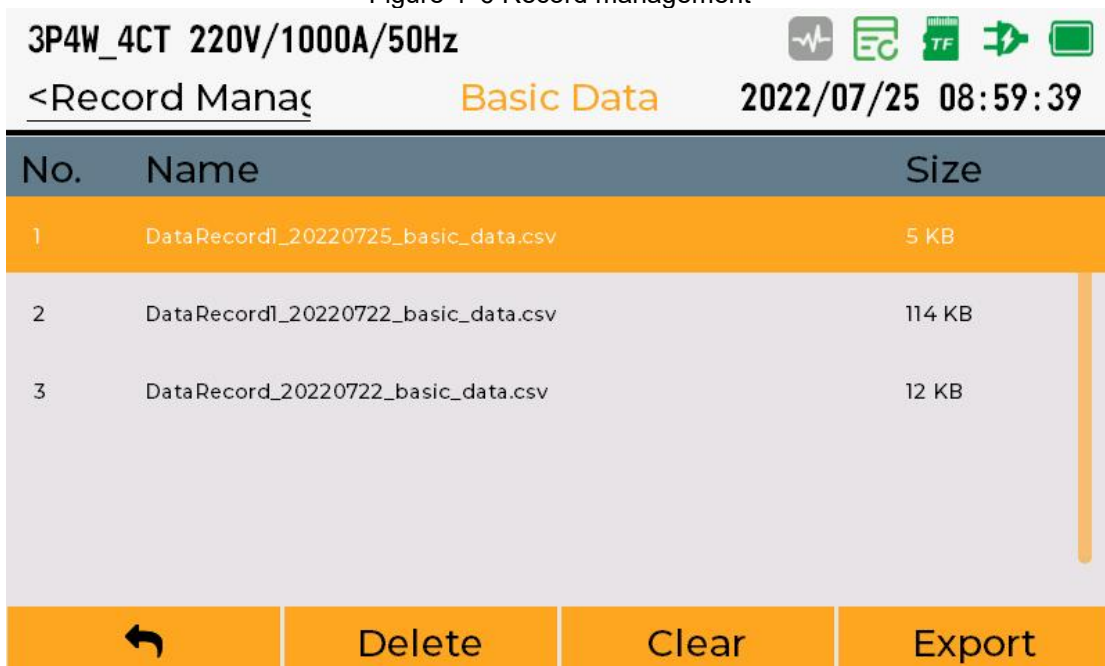

Figure 4-7 Data record

5 Operation and interface display

5.1 Function introduction

The operation interface of the analyzer is divided into three parts, including setup menu, measure menu and record menu. The functions of each menu are shown in Table 5-1.

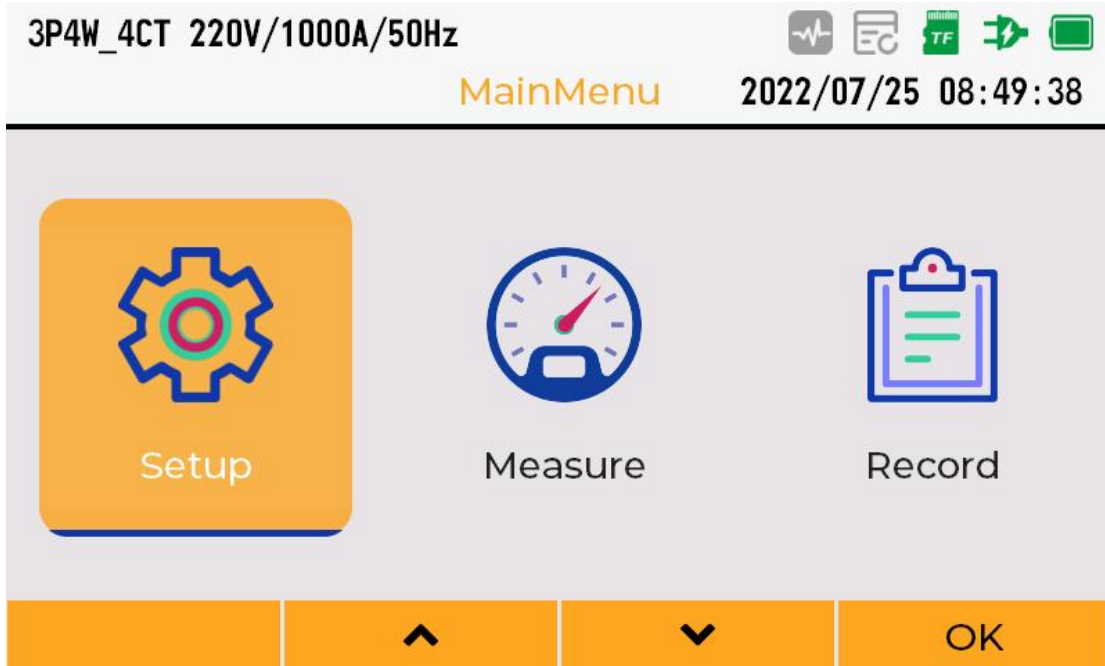

Figure 5- 1 Main interface
Table 5- 1 Main interface description

Menu	Main functions
Setup	<ul style="list-style-type: none"> Configure the wiring mode of the analyzer Voltage and current transformer parameters Configure event thresholds Configure communication parameters Configure user parameters
Measure	<ul style="list-style-type: none"> Display of basic parameters such as voltage, current, power and electric energy Voltage and current harmonic percentage and histogram display Voltage and current waveform display Phasor display Unbalance display Demand display
Record	<ul style="list-style-type: none"> Basic data recorder Waveform Recorder Record management (export, delete) Storage management (format)

5.2 Screen introduction

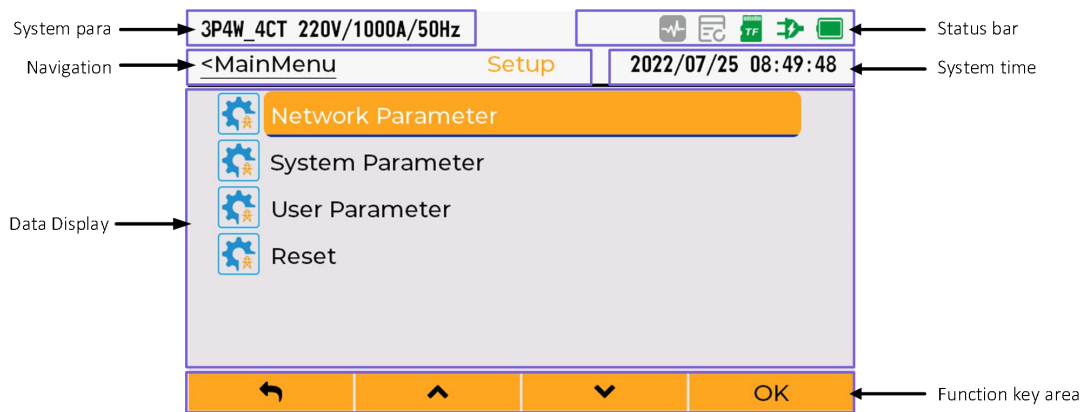

Figure 5-2 Interface introduction

The equipment interface is mainly divided into six functional areas: system parameter bar, navigation bar, status bar, system time, data display area and function key bar.





System parameter: display wiring mode, nominal voltage, current sensor type, nominal current and grid frequency.

Navigation bar: displays the location of the current interface and the superior interface.

Status bar: used to indicate the status of the system. The meaning of each status is shown in the Table 5-2 Status bar description:

Table 5-2 Status bar description

Function	Icon	Explanation
Ethernet status		No network cable insertion detected, the icon is not to be displayed.
		Network cable insertion detected, unconnected, the icon displays gray.
USB flash disk status		<ul style="list-style-type: none"> ◇ The USB flash disk is not inserted or unrecognized, and the icon is not displayed. ◇ The USB flash disk insertion normally initialized, the icon displays.
	Waveform recording status	
		Green, waveform recording in progress.
		Yellow, waveform recording completed
Data record status		Gray, data record not enabled
		Green, data recording in progress
		Yellow, data recording completed
Memory card status		TF abnormal, no TF card or TF card error detected
		TF card memory is full and needs to be cleaned up.

Function	Icon	Explanation
		TF card is normal.
Battery status		The battery is low and needs to be charged
		Battery remaining capacity display
		<ul style="list-style-type: none"> ✧ No adapter inserted, the adapter icon is not displayed. ✧ Inserting the adapter and charging the battery, the icon displays.

System time bar: displays the current system time.

Data display area: different pages will have different display contents.

Function key bar: corresponding to F1-F4 respectively, each page will have different functions.

5.3 Parameter setting interface

5.3.1 Introduction













The parameter setting interface is used to configure the wiring mode of the analyzer, voltage and current transformer parameters, event threshold, communication parameters, etc. Enter the setting interface through the key . The setting interface is shown in Figure 5-3, including power grid parameters, system parameters, user parameters and reset.



Figure 5-3 Setup Menu

5.3.2 Key operation

Press key   or key   to select the parameter to be modified; press key  to enter parameter editing, the corresponding data will flash; press key   or key   to modify the corresponding value; press key  to exit parameter editing, save the modified parameters; press key  to exit the current interface.

5.4 Power grid parameter setting

Power grid parameter settings are used to set wiring mode, power grid frequency, nominal voltage, current transformer, voltage transformer, event parameters, alarm settings and demand settings.

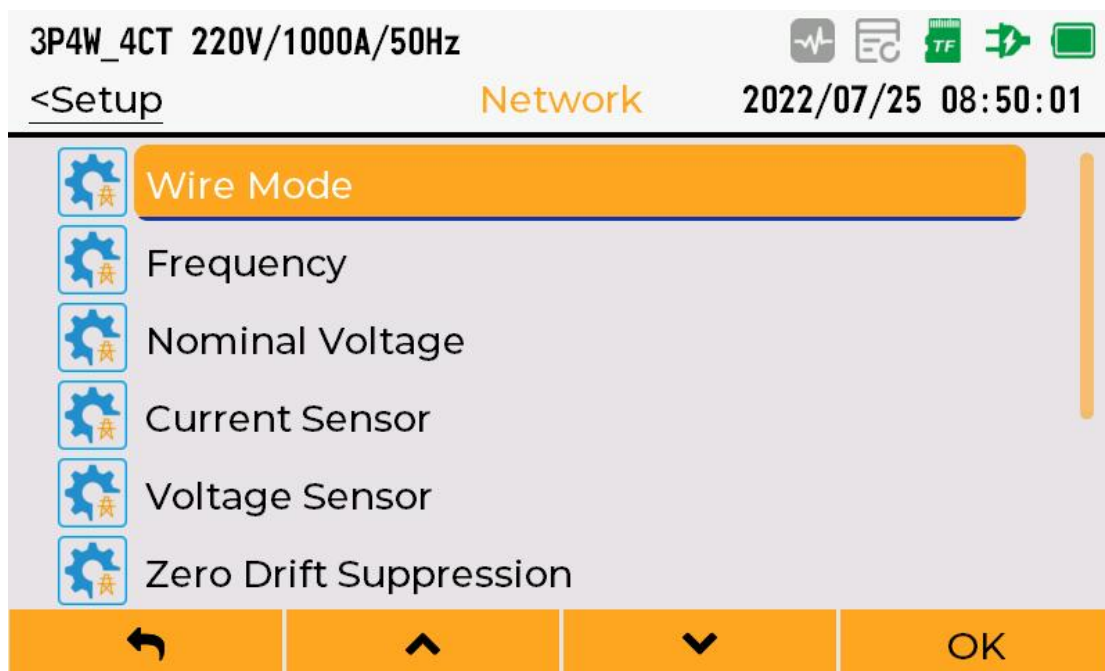

Figure 5-4 Grid parameters

5.4.1 Wiring mode setting

The wiring mode can be configured as: 3P4W_4CT, 3P4W_3CT, 3P3W_3CT, 3P3W_2CT and 1P2W, the configuration interface is shown in Figure 5-5 Wiring mode configuration.

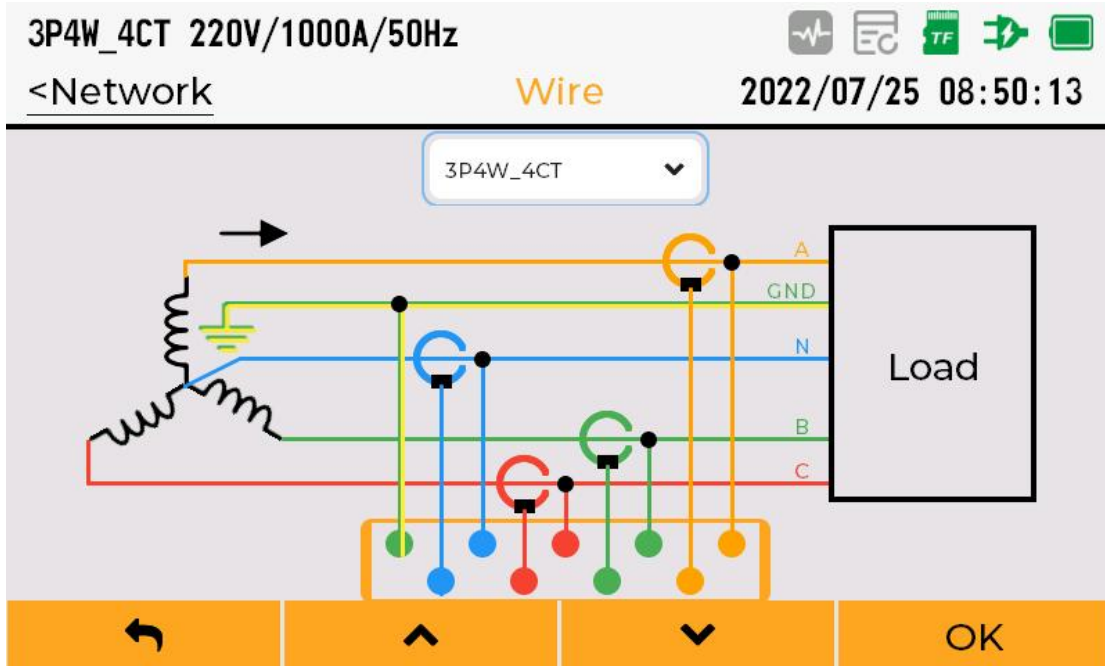

Figure 5-5 Wiring mode configuration

5.4.2 Power grid frequency configuration

It can be configured as 50Hz or 60Hz, the configuration interface is shown in Figure 5-6 Frequency configuration. It needs to be modified according to the actual frequency.

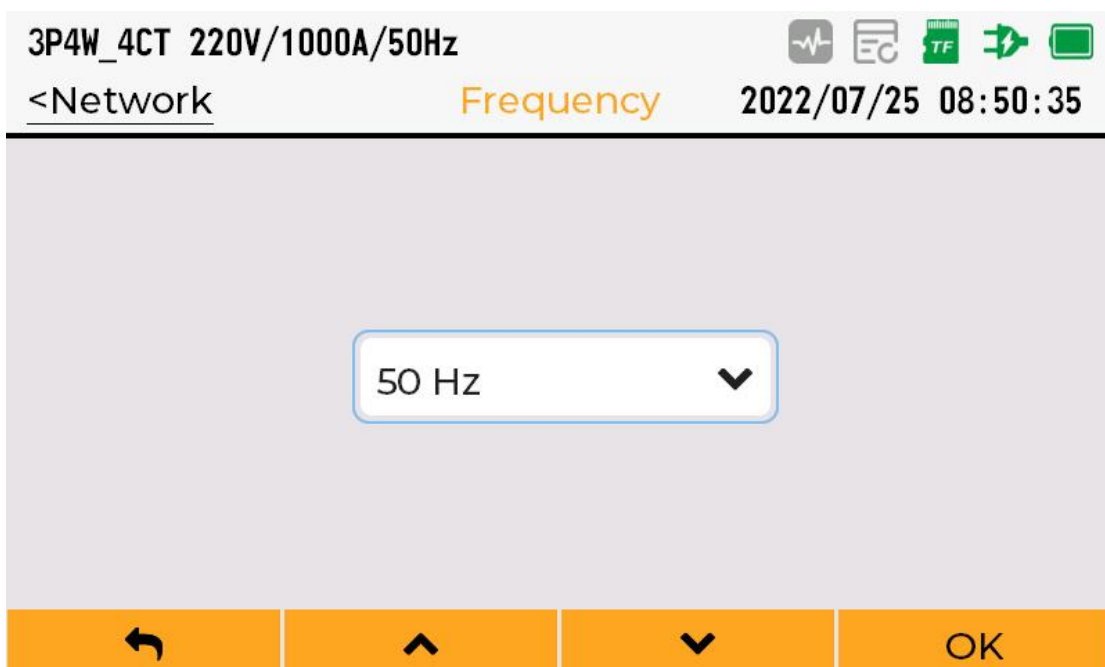

Figure 5-6 Frequency configuration

5.4.3 Nominal voltage setting

The nominal voltage is the reference voltage for voltage swells and dips, interruptions and overvoltage events. The nominal voltage can be set in the range of 1-99999V, the configuration interface is shown in

Figure 5-7 Nominal voltage configuration.

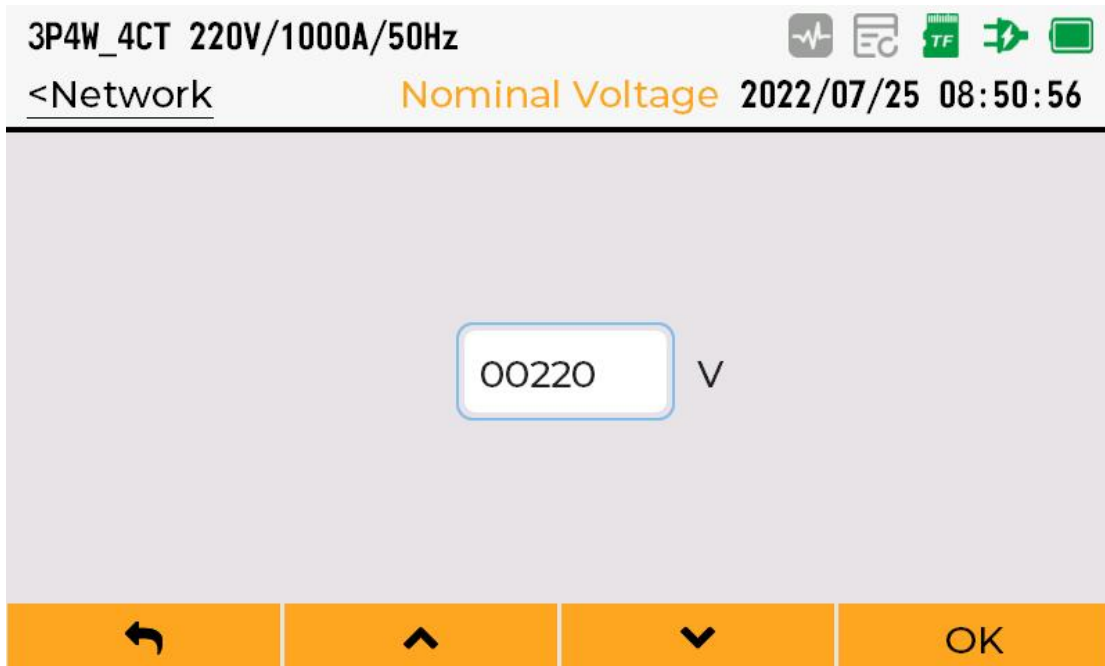

Figure 5-7 Nominal voltage configuration

5.4.4 Current transformer setting

The current transformer configuration interface is used to configure parameters such as sensor type, sensitivity, nominal current and transformation ratio. The specific parameter types are shown Table 5-3 Current transformer parameters:

Table 5-3 Current transformer parameters

Parameter name	Explanation
Sensor type	Rcoil: Rogowski coil CT: Voltage output type CT
Sensitivity	When the sensor type is rcoil, the unit is mV/kA@50Hz When the sensor type is CT, the unit is mV/A
Nominal current	The unit is A, indicating the nominal current to be measured, range 1-99999
Transformation ratio	Current conversion ratio, range 0.0001-1000.0

The configuration interface is shown in Figure 5-8 Current transformer configuration.

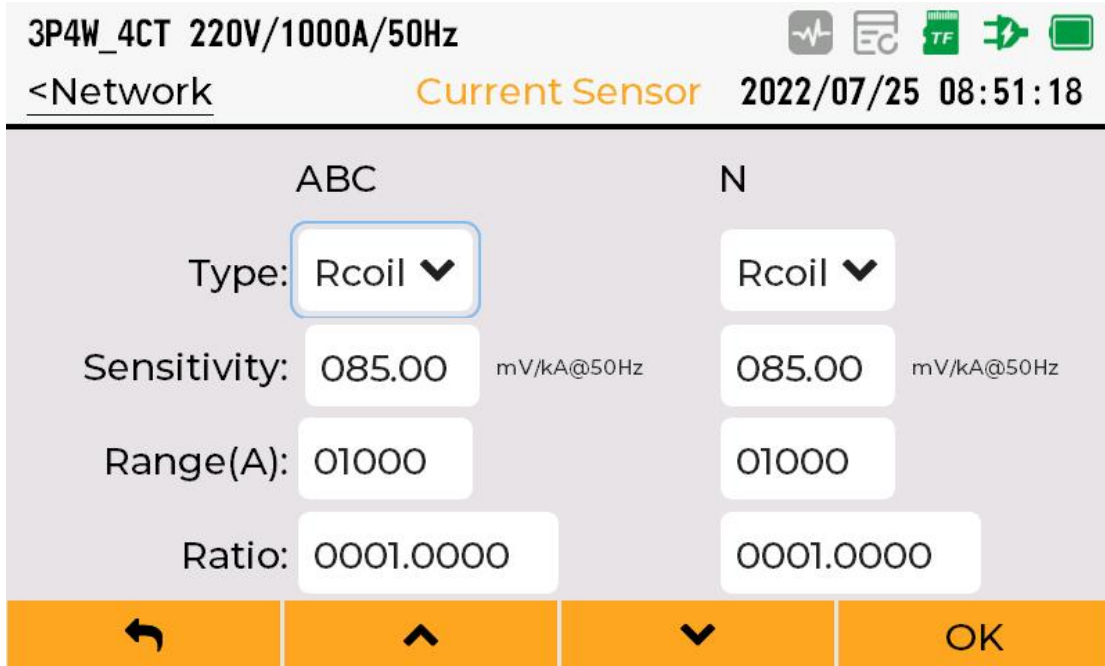

Figure 5-8 Current transformer configuration

5.4.5 Voltage transformer setting

The voltage transformer interface is used to configure the transformation ratio of voltage transformer. The configuration interface is shown in Figure 5-9 Voltage transformer configuration.

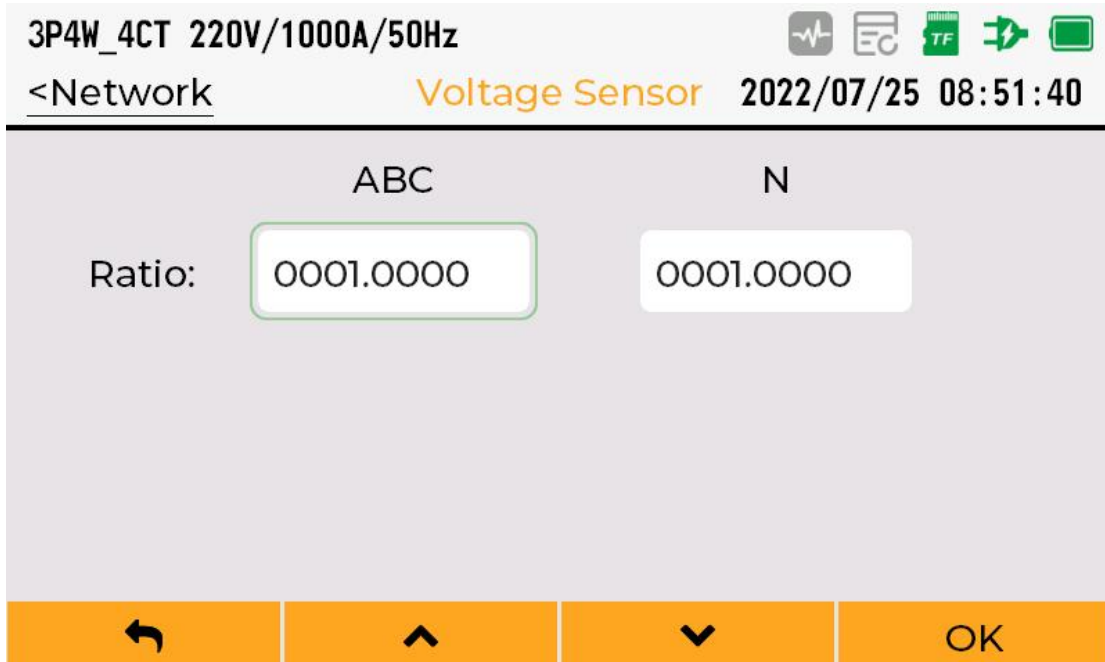

Figure 5-9 Voltage transformer configuration

5.4.6 Zero drift suppression setting

The zero drift suppression setting interface is used to configure displaying the minimum current and voltage to prevent from value jumping when there is no voltage or current. Relative to the nominal voltage, the voltage zero drift suppression percentage can be set in the range of 0%~10%; Relative to the nominal current, the current zero drift suppression percentage can be set in the range of 0%~10%;

The configuration interface is shown in Figure 5-10 Zero drift suppression setting.



Figure 5-10 Zero drift suppression setting

5.4.7 Harmonic calculation threshold setting

The harmonic calculation threshold setting interface is used to configure the minimum voltage and current value of voltage and current FFT operation. When the voltage or current is less than the harmonic calculation threshold, harmonic calculation will not be carried out. The voltage threshold percentage is relative to the nominal voltage and the current threshold percentage is relative to the nominal current. The settable range is 0%-10%.

The configuration interface is shown in Figure 5-11 Harmonic calculation threshold setting.

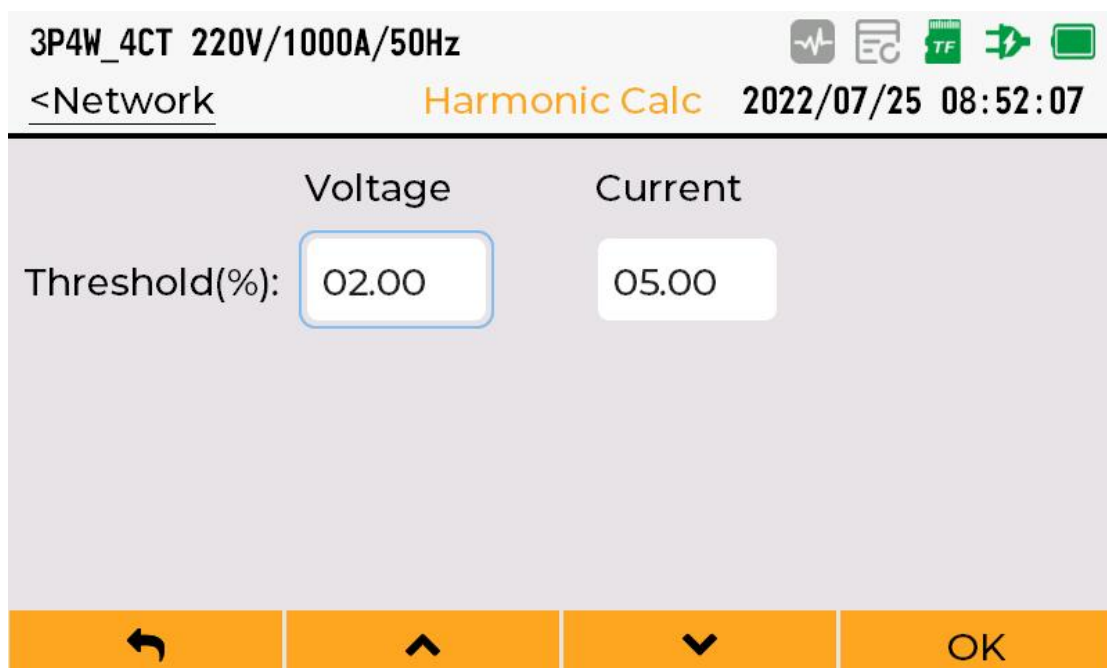

Figure 5-11 Harmonic calculation threshold setting

5.4.8 Event parameter setting

Event parameters are used to configure the thresholds of multiple electric energy parameters. Configurable event parameters are shown in Table 5-4 Event parameter list:

Table 5-4 Event parameter list

Parameter name	Setting range	Default value	Remarks
Voltage swell threshold (%)	105.0~140.0	110.0	Nominal voltage as reference
Voltage swell hysteresis value (%)	1.0~6.0	2.0	Nominal voltage as reference
Voltage dip threshold (%)	75.0~95.0	90.0	Nominal voltage as reference
Voltage dip hysteresis value (%)	1.0~6.0	2.0	Nominal voltage as reference
Voltage interruption threshold (%)	1.0~10.0	5.0	Nominal voltage as reference
Voltage interruption hysteresis value (%)	1.0~6.0	2.0	Nominal voltage as reference
Overfrequency threshold (%)	100.1~120.0	101.0	Nominal frequency as reference
Low frequency threshold (%)	50.0~99.9	99.0	Nominal frequency as reference
Overvoltage threshold (%)	101.00~200.00	110.00	Nominal voltage as reference
Low voltage threshold (%)	1.00~99.00	90.00	Nominal voltage as reference
Overcurrent threshold (%)	101.00~200.00	110.00	Nominal current as reference
Low current threshold (%)	1.00~99.00	90.00	Nominal current as reference
Voltage unbalance degree threshold (%)	0.01~99.99	4.00	
Current unbalance degree threshold (%)	0.01~99.99	10.00	
Voltage total harmonic threshold (%)	0.01~99.99	5.00	
Voltage even harmonic threshold (%)	0.01~99.99	5.00	
Voltage odd harmonic threshold (%)	0.01~99.99	5.00	
Current total harmonic threshold (%)	0.01~99.99	5.00	
Current even harmonic threshold (%)	0.01~99.99	5.00	
Current odd harmonic threshold (%)	0.01~99.99	5.00	

The configuration interface is shown Figure 5-12 Event parameter configuration.

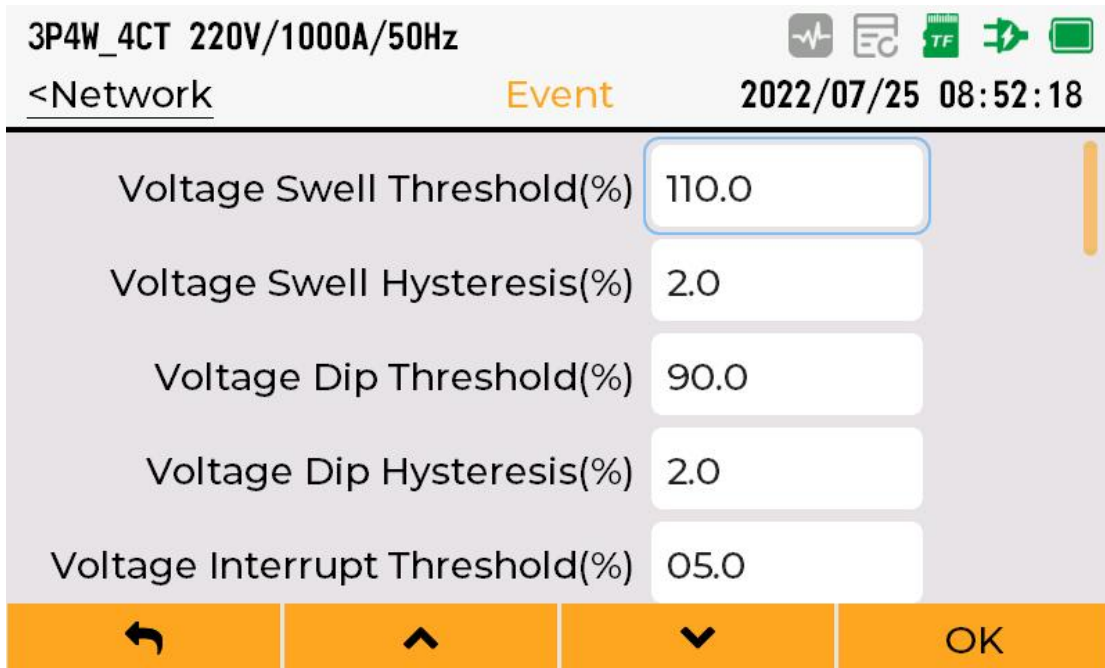

Figure 5-12 Event parameter configuration

5.4.9 Demand setting

The demand setting interface is used to configure parameters such as demand calculation method and calculation interval. The specific parameter types are shown in Table 5-5 Demand parameters:

Table 5-5 Demand parameters

Parameter name	说明
Calculation method	Fixed: update the demand according to the calculation interval Sliding type: update the demand once a minute
Calculation interval	Unit: minutes Range: 1-60

The configuration interface is shown in Figure 5-13 Demand setting.

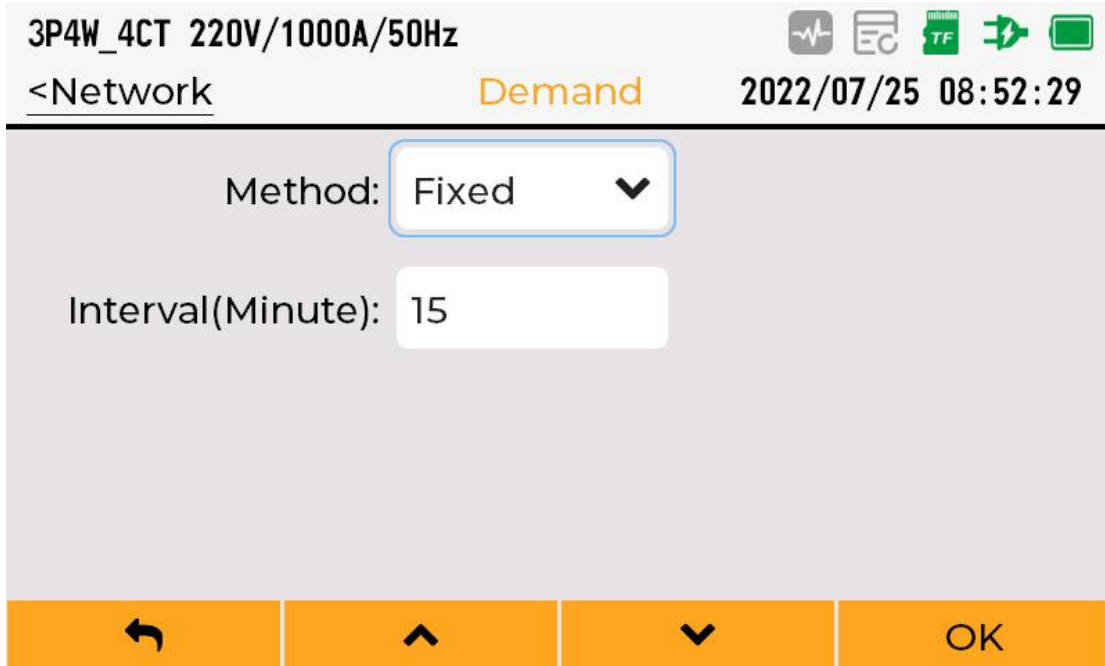

Figure 5- 13 Demand setting

5.4.10 CO2 Emission factor setting

The CO2 emission factor setting interface is used to calculate the CO2 emission corresponding to the current electric energy consumption, and the setting range is 0~9999.99.

The configuration interface is shown in Figure 5- 14 CO2 Emission factor setting.

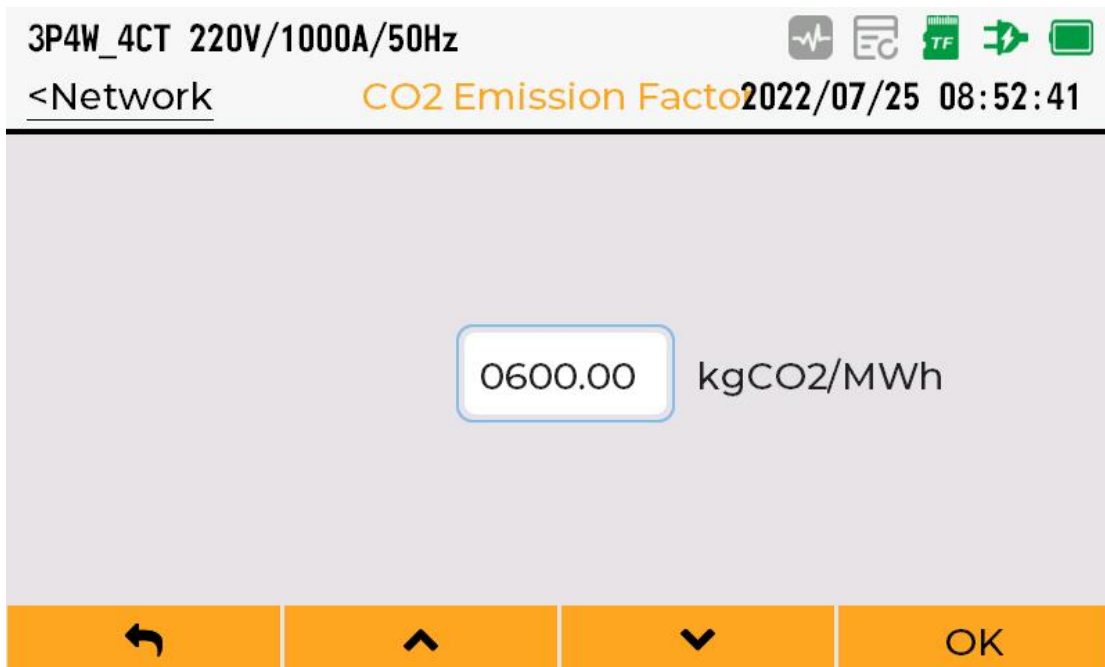

Figure 5- 14 CO2 Emission factor setting

5.5 System parameter setting

System parameter settings are used for system information viewing, communication settings, clock settings, screen settings, keyboard settings and language settings.

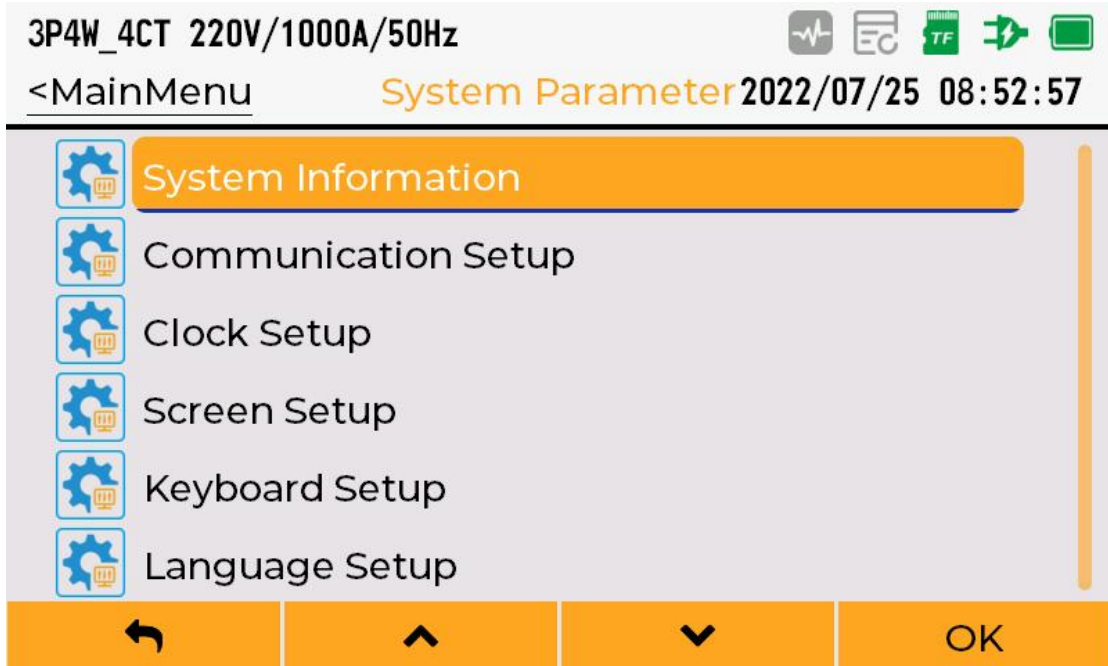

Figure 5- 15 System parameter

5.5.1 System information

The system information displays the equipment model, serial number, firmware version number, hardware version number and Ethernet parameters.



Figure 5- 16 System information

5.5.2 Communication settings

Communication settings are used to set Ethernet communication parameters and Modbus TCP communication parameters.

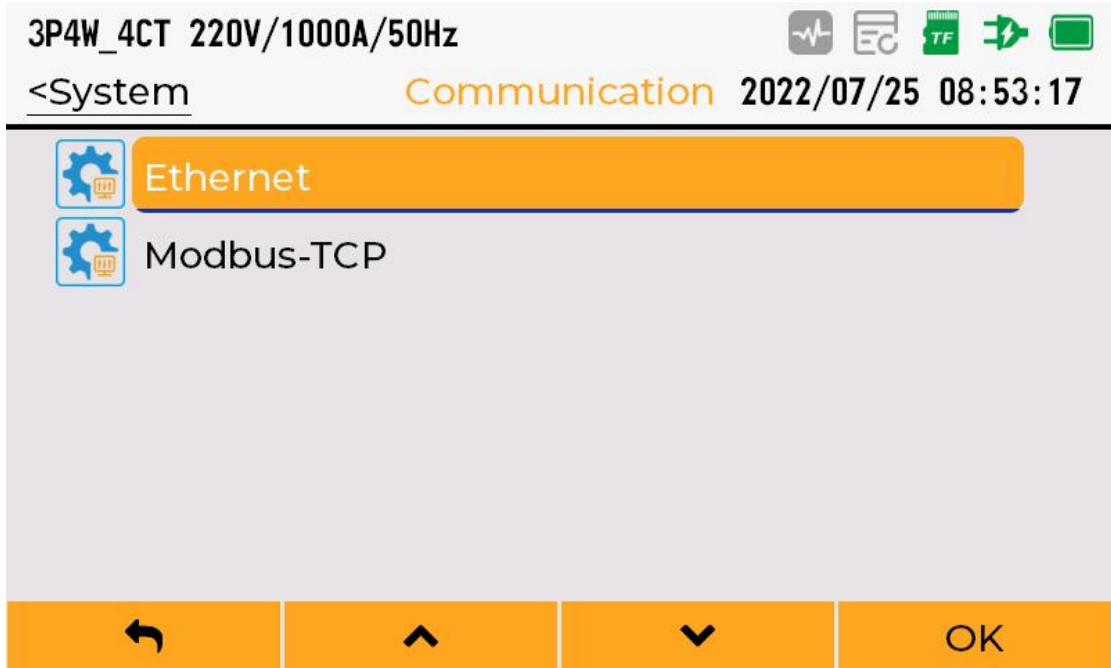

Figure 5- 17 Communication settings

Ethernet parameter settings are used to set the IP acquisition method. Automatic IP acquisition is disabled by default, and the default IP is 192.168.1.55.

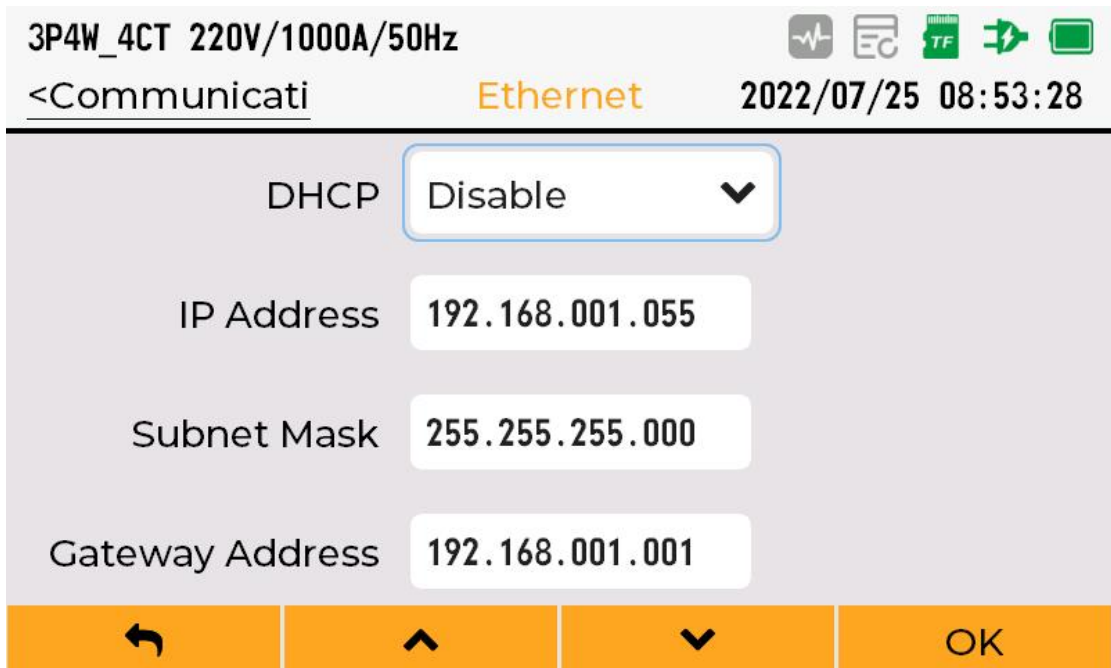

Figure 5- 18 Ethernet settings

Modbus TCP communication parameters are used to set whether it is enabled and the communication port number.



Figure 5- 19 Modbus-TCP setting

5.5.3 Clock setting

Clock setting is used to set the display format of the date, as well as calibration time.

The date display format can be set to: yyyy/mm/dd、 mm/dd/yyyy、 dd/mm/yyyy.

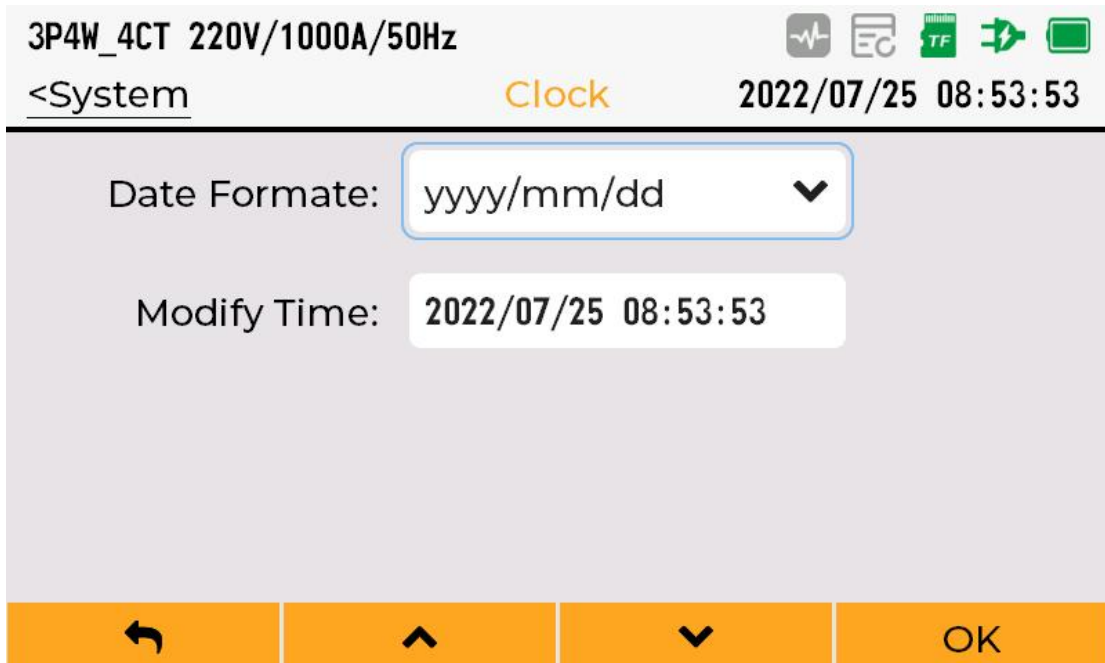

Figure 5- 20 Clock setting

5.5.4 Screen setting

Screen setting is used to set the backlight brightness and screen rest time of the screen.

The screen backlight brightness can be set to: 1, 2, 3, 4, 5.

The automatic dormant screen can be set as: disabled, 1 minute, 5 minutes, 10 minutes, 30 minutes. When it is set as disabled, the screen is always on; when it is set to non disabled, the screen will be automatically dormant when there is no key operation after the set time.

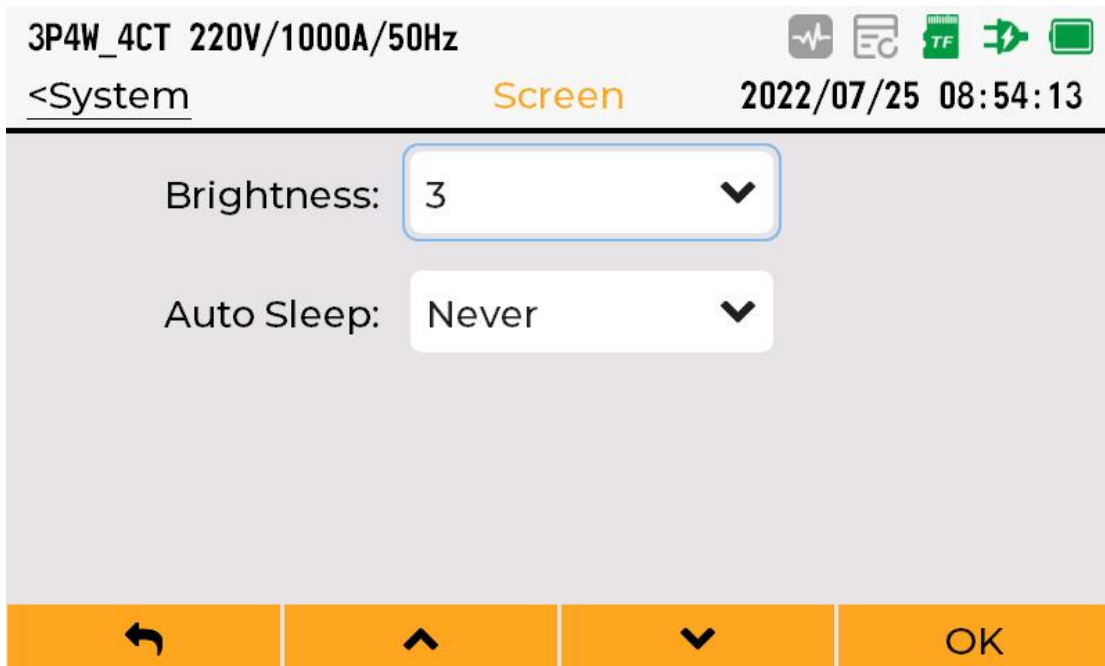

Figure 5-21 Screen setting

5.5.5 Keyboard setting

Keyboard setting is used to set the keyboard tone and key automatic locking.

When the keyboard tone is set to enabled, press the key and the buzzer will sound.

The automatic locking of the keyboard can be set as: disabled, 1 minute, 2 minutes, 3 minutes, 4 minutes and 5 minutes. When it is set as disabled, the keys do not lock automatically; when it is set to non disabled, if there is no key operation after the set time, the key will be locked.

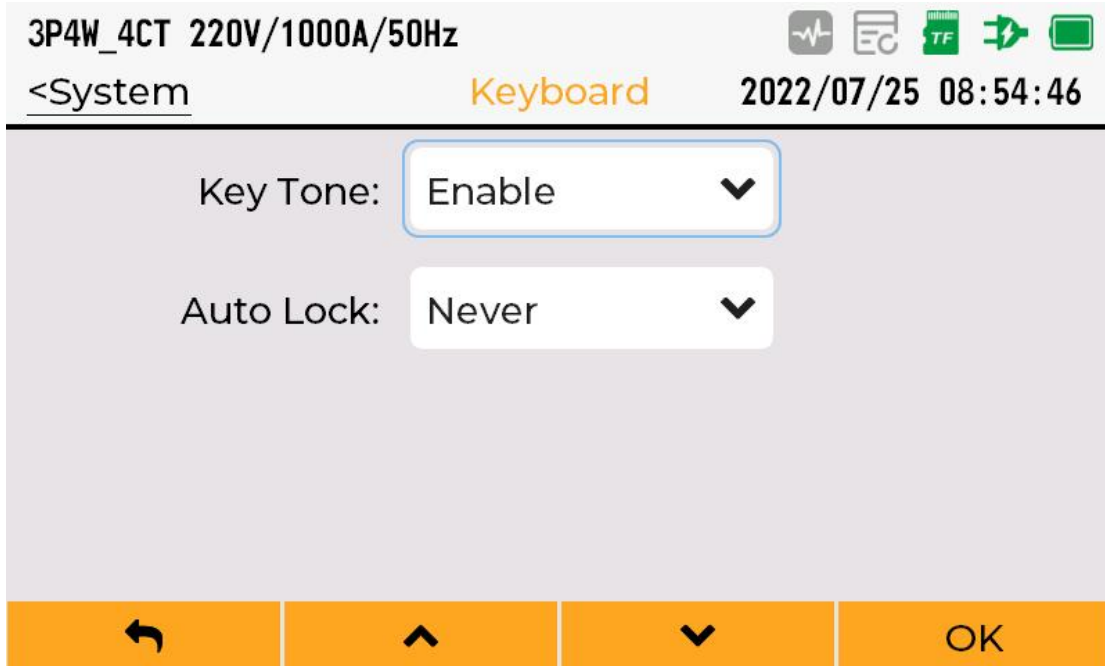

Figure 5-22 Keyboard setting

5.5.6 Language setting

Language setting is used to set language of the interface displayed.

The languages that can be set are: Chinese (Simplified), English, Chinese (traditional), French, Russian, Spanish and Portuguese.

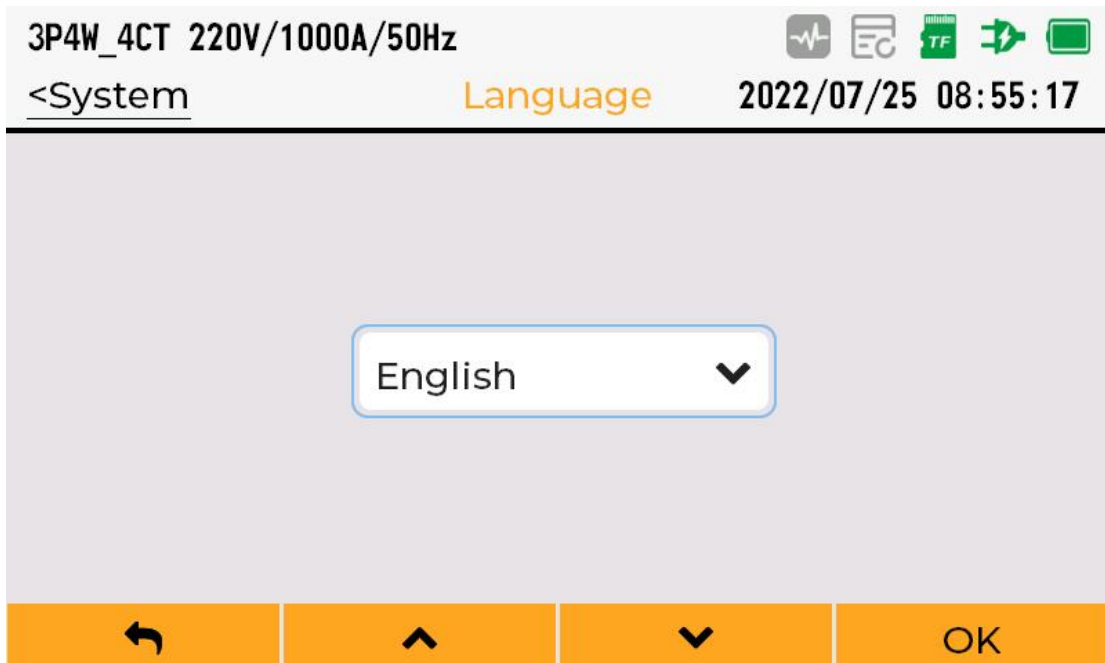

Figure 5-23 Language setting

5.6 User parameter setting

User parameter settings are used for setting user information, phase sequence name and phase sequence color.

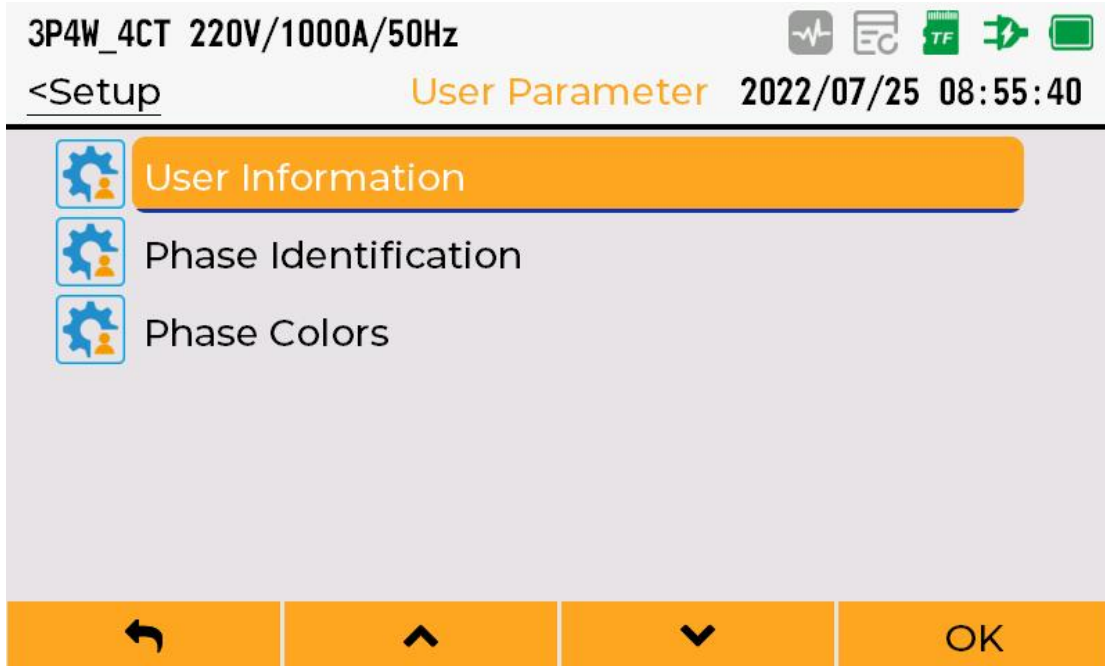







Figure 5-24 User parameter setting

5.6.1 User information setting

The user information interface is used to set the user name and location information, which is stored in the record file.

Press key   or key   to select the parameter to be modified; press key  to enter parameter editing.

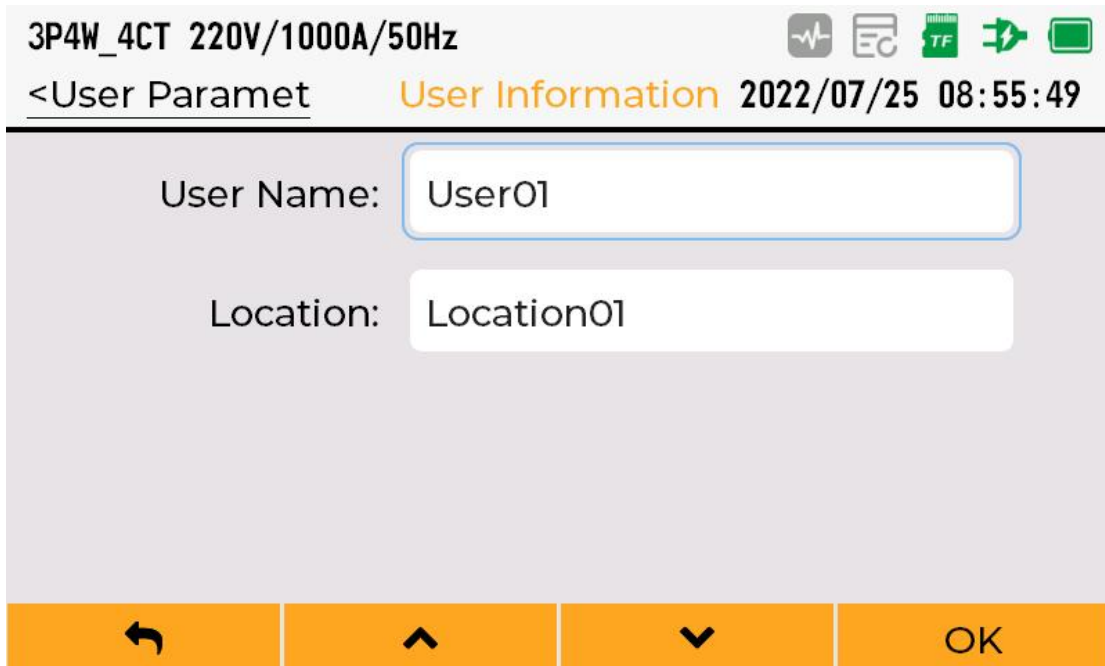





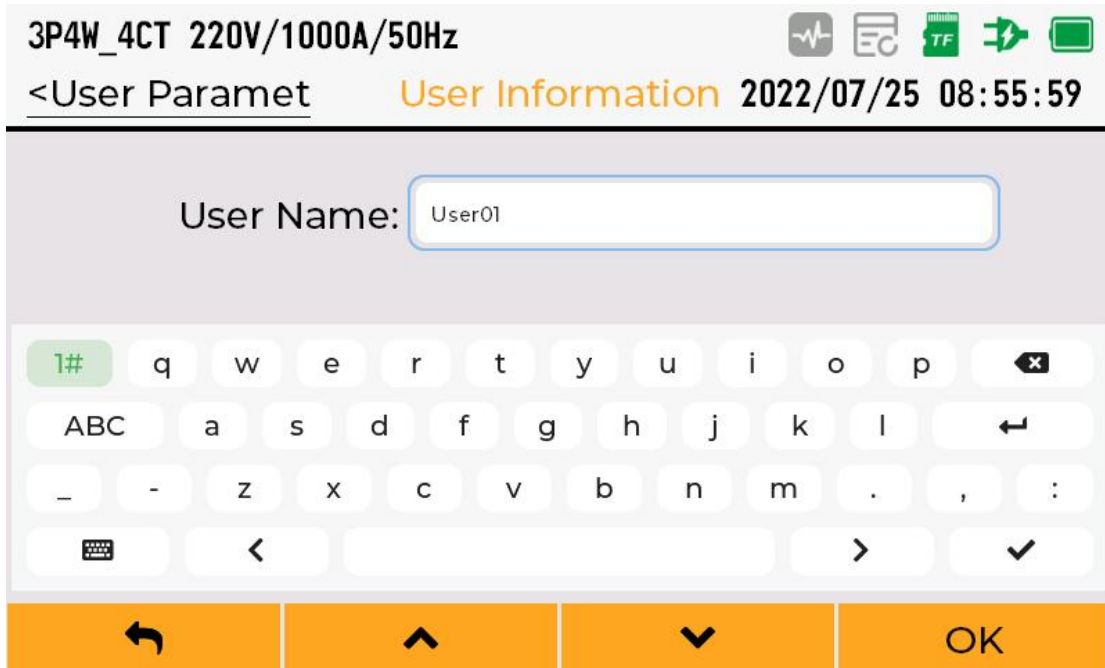

Figure 5-25 User information setting

In the user name modification interface, press key   or key   to select the data to be entered; press key  to confirm the input.

Press  to exit the current interface.



5.6.2 Phase sequence name setting

The phase sequence name interface is used to set the phase sequence as ABC or L1L2L3.

The phase sequence name is used to display the phase sequence of the measurement interface.

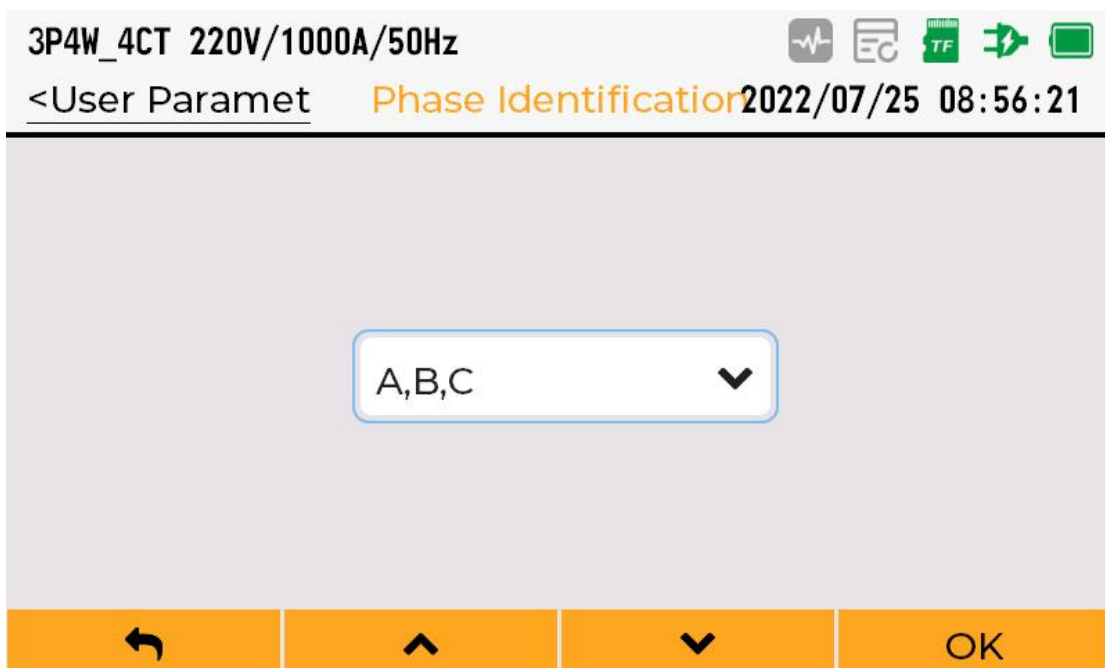





Figure 5-26 Phase sequence name setting

5.6.3 Phase sequence color setting

The phase sequence color interface is used to set the color of phase sequence. The standards are divided into Chinese standards, American standards, IEC standards and user-defined.

Chinese standards, American standards, IEC standards: the phase sequence color is fixed and cannot be modified.

User-defined: the phase sequence color can be customized and modified. Press key  , to select the phase sequence to be modified; press key  to select the color.

Press  to exit the current interface.

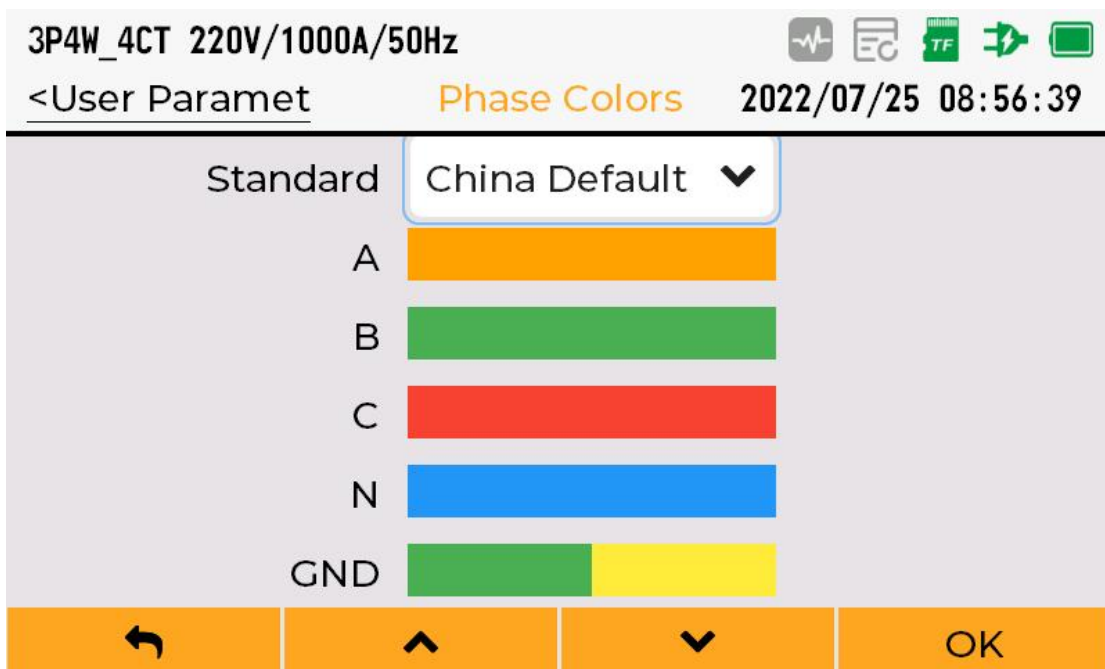

Figure 5-27 Phase sequence color setting

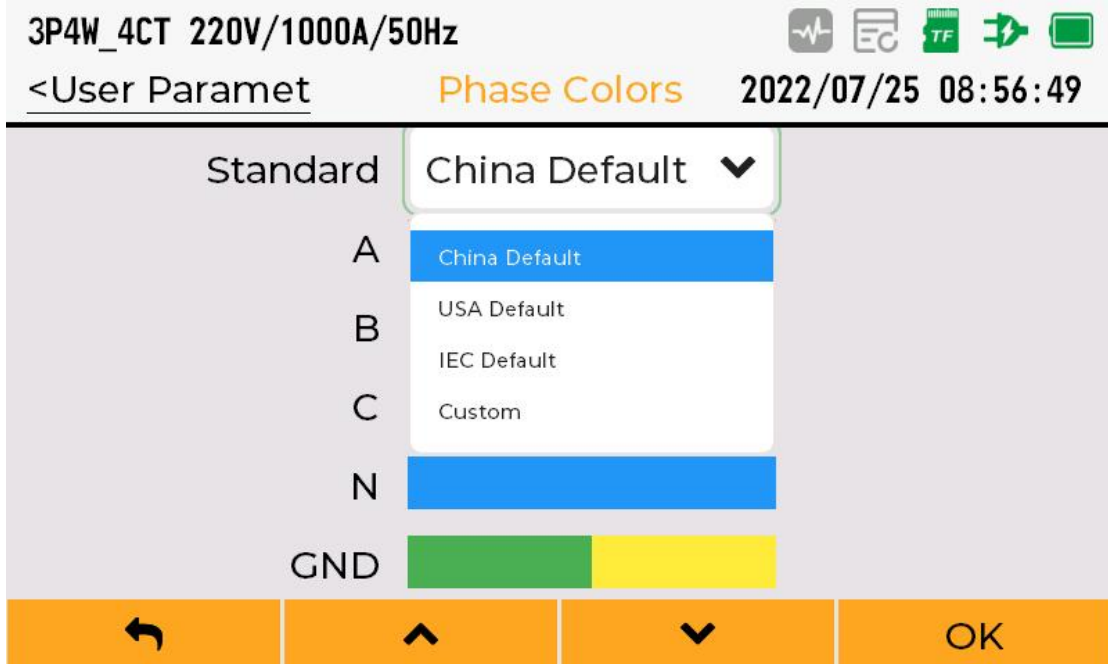

Figure 5- 28 Phase sequence color customization

5.7 Reset

The reset interface includes restoring factory settings, resetting electric energy, and resetting the peak demand.



Press the key   to select the type to reset; Press the key  to confirm the selection.



Figure 5- 29 Reset interface

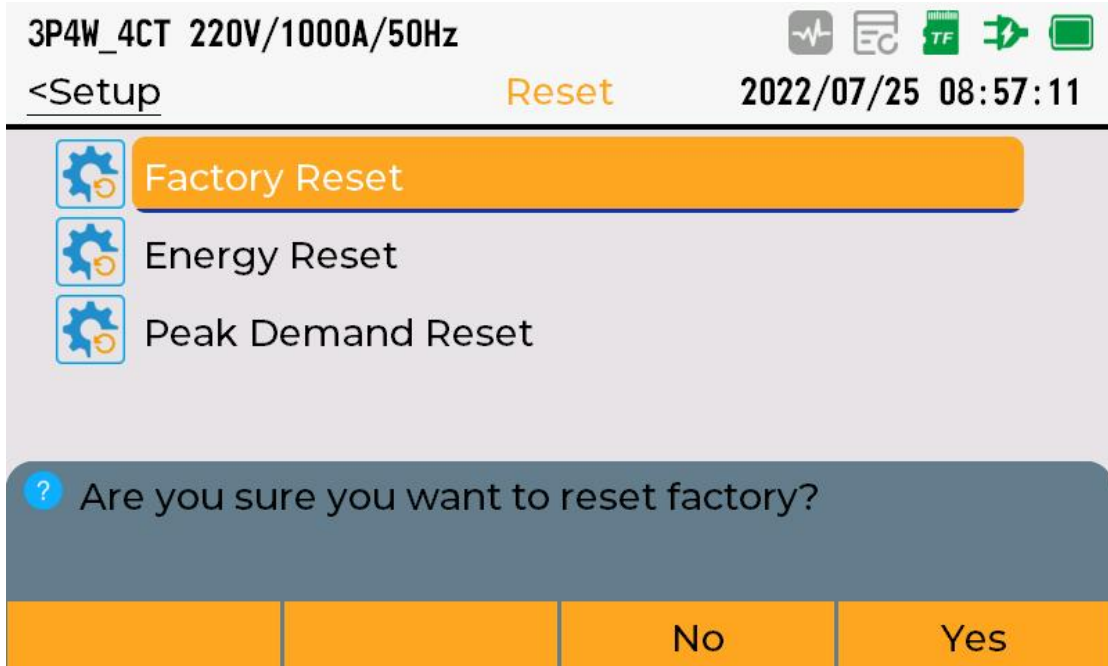

Figure 5-30 Operation confirmation interface

5.8 Measurement interface

5.8.1 Introduction





The measurement interface is used to display voltage, current, power, electric energy, harmonic, waveform, vector diagram, unbalance degree, demand, etc. Press the key  to enter the measurement interface, it is shown in Figure 5-31 Measurement interface.



Figure 5- 31 Measurement interface

5.8.2 Key operation

Press the key   to select the data to view or page up and down; press the key  to enter the data view interface; press  to exit the current interface.

5.9 Voltage and current

The voltage and current interface is used to view the effective value of phase voltage, peak coefficient CF, peak PK, grid frequency, line voltage, current effective value, current peak coefficient CF and current K coefficient KF.

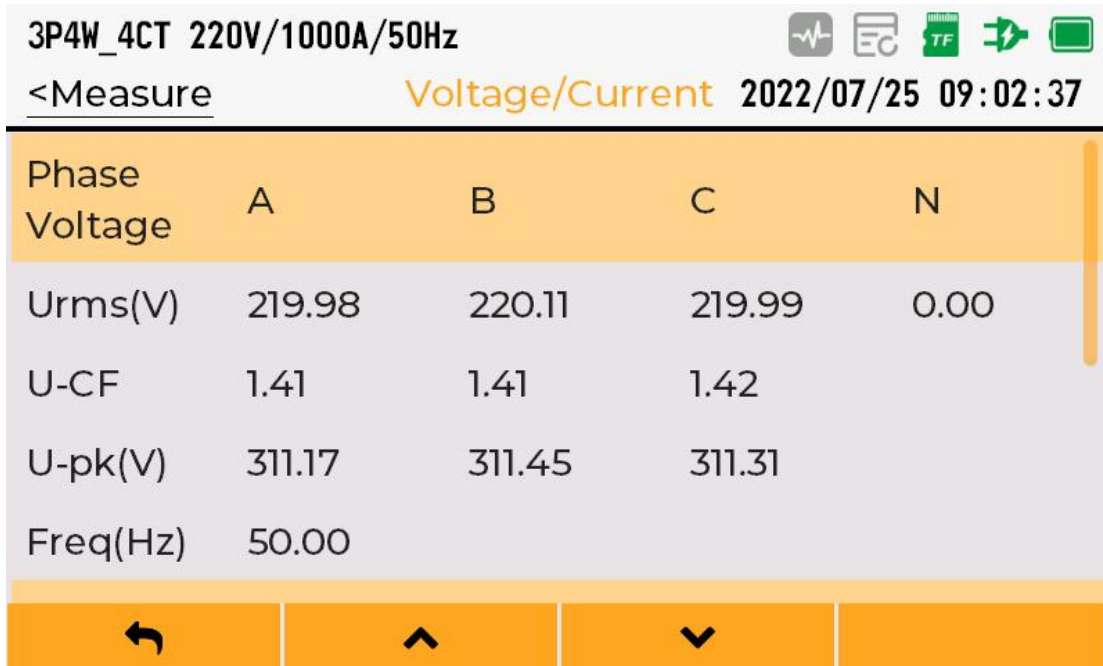

Phase	A	B	C	N
Urms(V)	219.98	220.11	219.99	0.00
U-CF	1.41	1.41	1.42	
U-pk(V)	311.17	311.45	311.31	
Freq(Hz)	50.00			

Figure 5- 32 Voltage and current

5.10 Power

The power interface is used to check the active power P, reactive power Q, apparent power S, power factor PF and fundamental power factor DPF.

3P4W_4CT 220V/1000A/50Hz				
<Measure		Power		2022/07/25 09:03:00
Power	A	B	C	Total
P(kW)	21.988	21.998	21.971	65.957
Q(kVar)	38.098	38.143	38.131	114.372
S(kVA)	44.001	44.027	44.002	132.030
PF	0.500	0.499	0.499	0.500
DPF	0.500	0.499	0.499	0.500

Figure 5-33 Power

5.11 Energy

The energy interface is used to view the active positive energy EP_ Imp, active reverse energy EP_ Exp, reactive positive energy EQ_ Imp, reactive reverse energy EQ_ Exp, apparent energy ES and CO2 emissions.

3P4W_4CT 220V/1000A/50Hz				
<Measure		Energy		2022/07/25 09:03:12
Energy	A	B	C	Total
EP_imp (Wh)	37243	37067	36510	110820
EP_exp (Wh)	0	0	2	2
EQ_imp (Varh)	60670	60175	60346	181191

Figure 5-34 Energy

5.12 Harmonic

The harmonic interface is used to view the total harmonic of voltage and current, the value of 1st-50th harmonic, and the histogram.

F4 The key is used to switch whether the current page is a histogram display page or a numerical display page. On the histogram page, the key **F2** is used to switch the voltage and current display, the key **F3** is used to switch the displayed phase.



the key is used to move the cursor and display the current harmonic percentage.



the key is used for scaling the histogram.

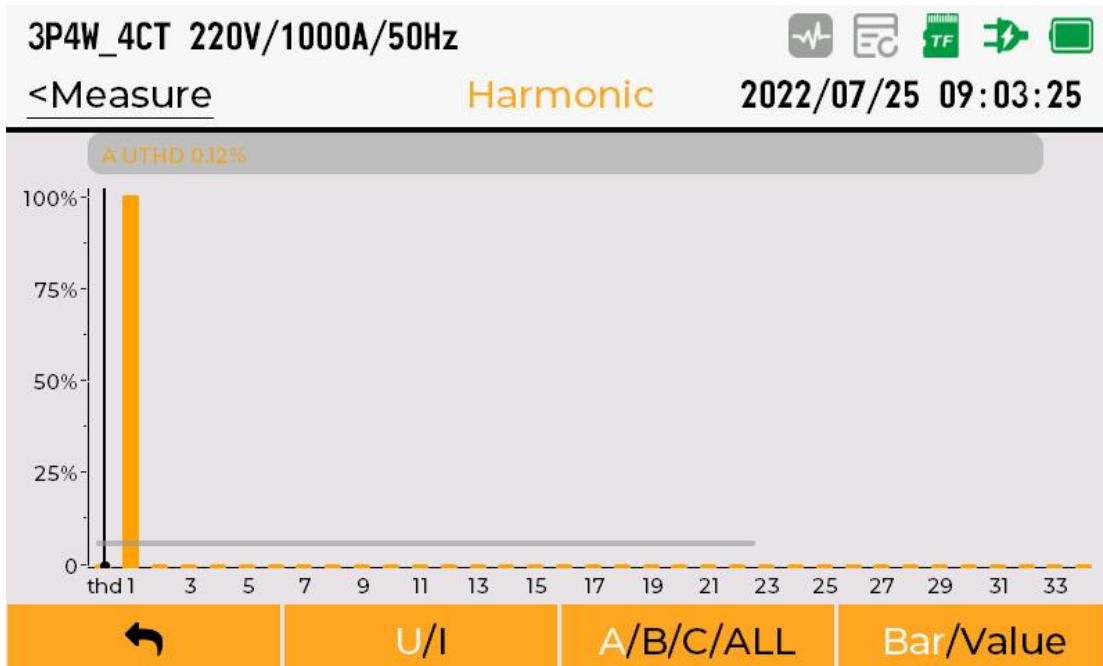

Figure 5-35 Harmonic histogram display

On the numerical value page, the key **F2** is used to switch the voltage and current display. The key **F3** to switch the harmonic percentage and harmonic value display.



is used for page turning display.

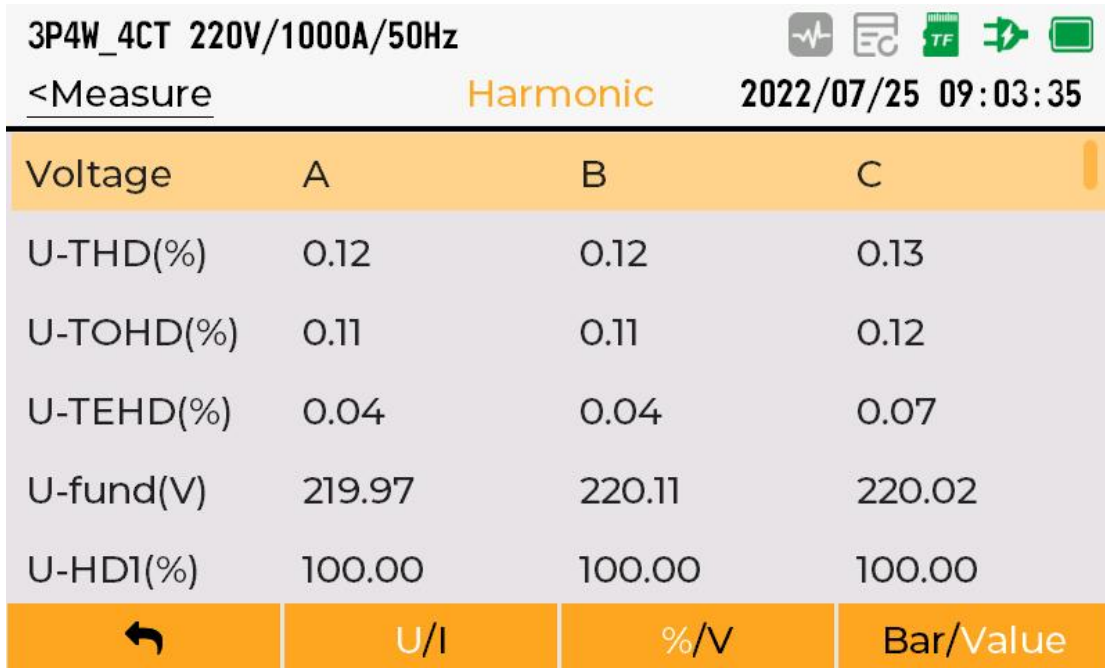

Figure 5- 36 Harmonic value display

5.13 Waveform

The waveform interface is used to view the waveform of three-phase voltage and three-phase current.

The waveform interface has two coordinate axes. The left coordinate axis represents the voltage value and the right coordinate axis represents the current value.

F4 The key is used to select whether the waveform is refreshed. When it is "hold", the waveform data will not be refreshed.

F3 The key is used to select the phase currently displayed.

F2 The key is used to select whether to display voltage waveform, current waveform or both.



The key is used to scale the waveform display.

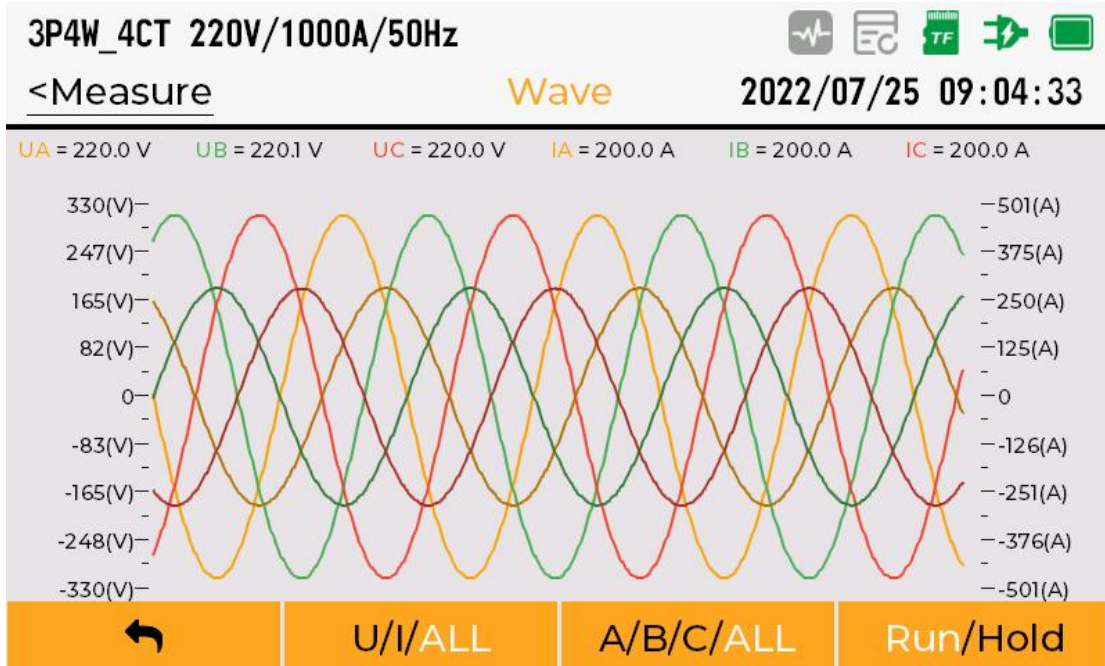

Figure 5- 37 Voltage and current waveform display

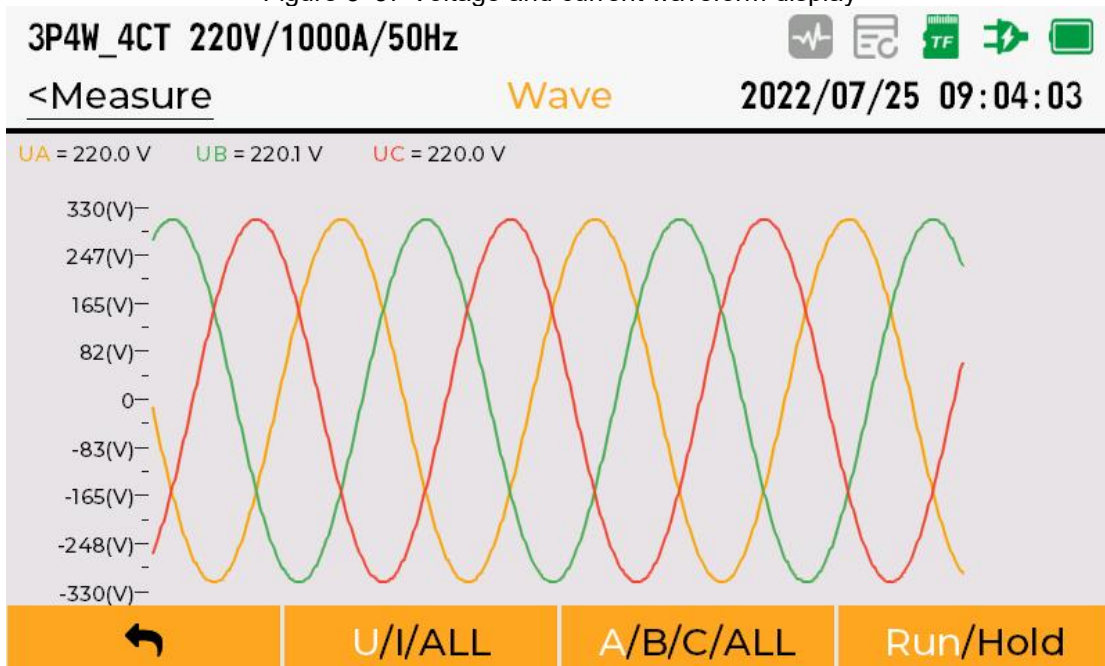

Figure 5- 38 voltage waveform display

5.14 Phasor

The phasor interface is used to display the angular dependence and value between voltage and current.

The vector diagram takes phase A voltage as a reference.

Solid arrows are voltage vectors and hollow arrows are current vectors.

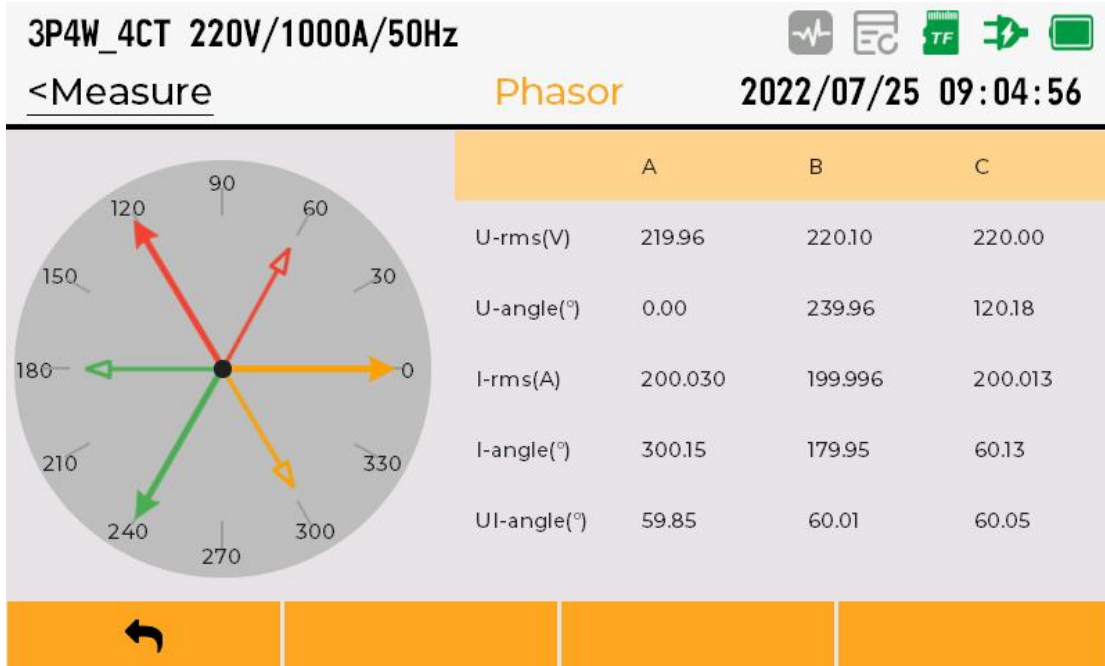

Figure 5- 39 Vector diagram display

5.15 Unbalance

The unbalance interface is used to display the unbalance of negative sequence and zero sequence of voltage and current.



Figure 5- 40 Unbalance degree display

5.16 Demand

The demand interface is used to display the current and power demand and the peak demand.

F4 The key is used to switch the display of current demand and peak demand.

 The key is used for page turning display.

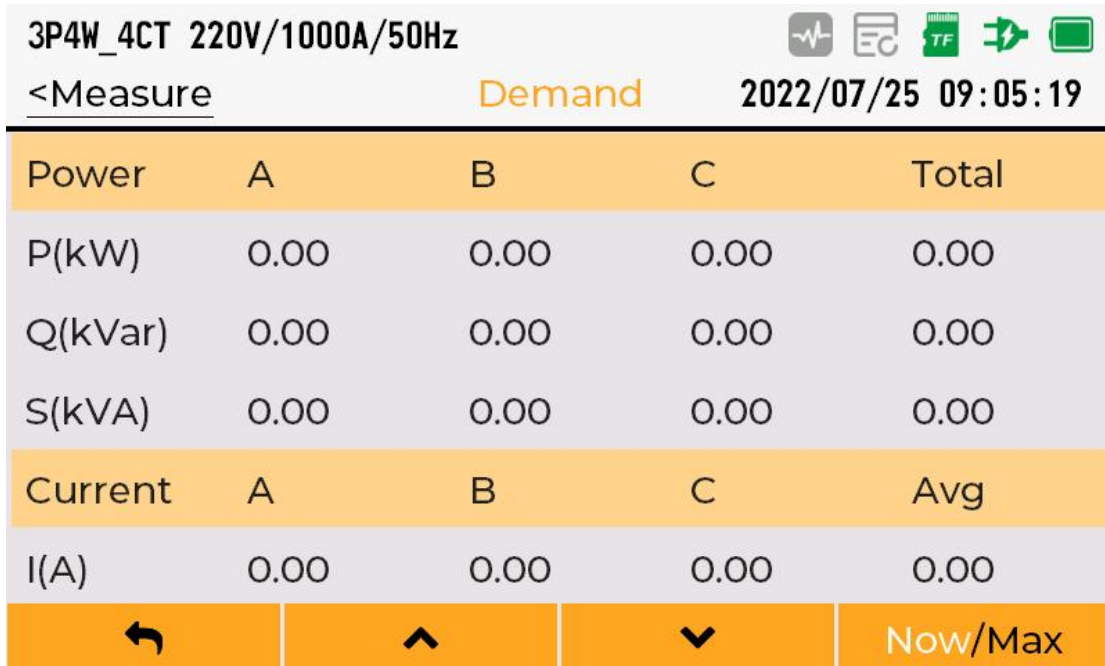

Figure 5-41 Current demand

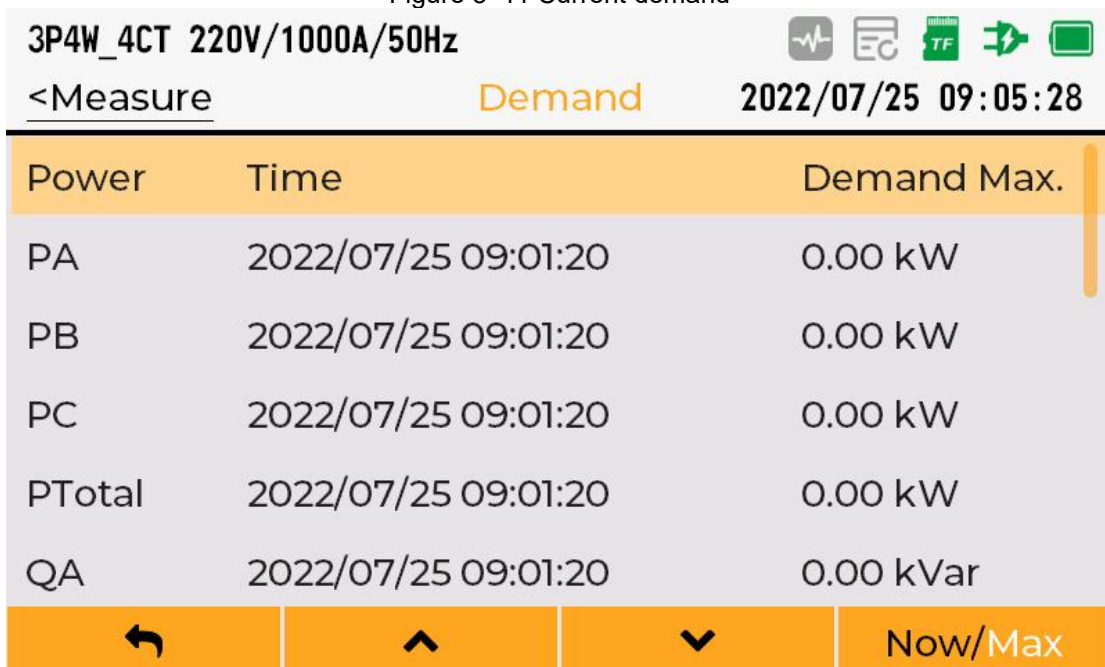

Figure 5-42 Peak demand

5.17 Recording interface

5.17.1 Introduction

The recording interface is used for data recording, waveform recording, record management, storage













management, etc. Through the key  to enter the recording interface. The recording interface is shown in Figure 5-43 Recording interface.



Figure 5-43 Recording interface

5.17.2 Key operation

Press the key   or   to elect the parameter to be modified; press the key  to enter parameter editing, the corresponding data will flash; press the key   or   to modify the corresponding value; press the key  to exit parameter editing, save modified parameters; press  to exit the current interface.

5.18 Data recorder

Data recorder is used to record basic data, voltage harmonic data and current harmonic data.

Record name: used to set the name of the record file. The maximum length is 20. The record file name will automatically include the record starting time.

Start time: used to set when recording starts. When pressing the key  to start recording, if the start time is less than the current time +10 seconds, the start time will be automatically modified to the current time +10 seconds.

Duration: used to set the duration of recording, which can be set to 1h\2h\4h\8h\16h\24h\2d\7d\30d\3mo\6mo\

12mo\Max, Max means recording all the time.

Recording interval (s): used to set how often to record. The default is 60s, the minimum is 5s, and the

maximum is 9999s.

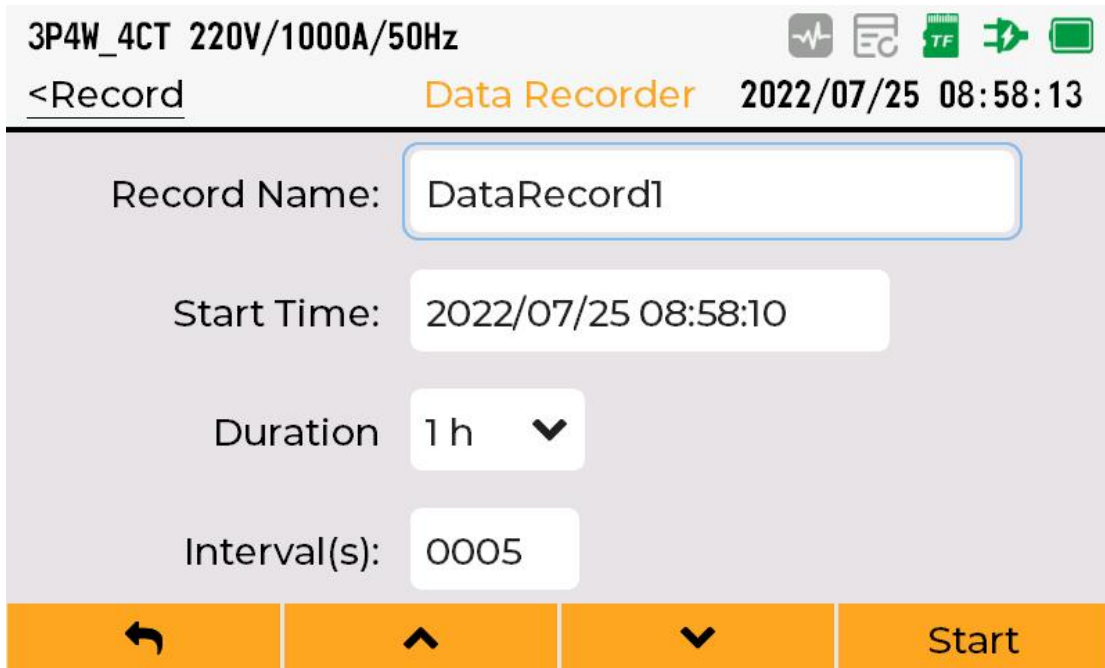
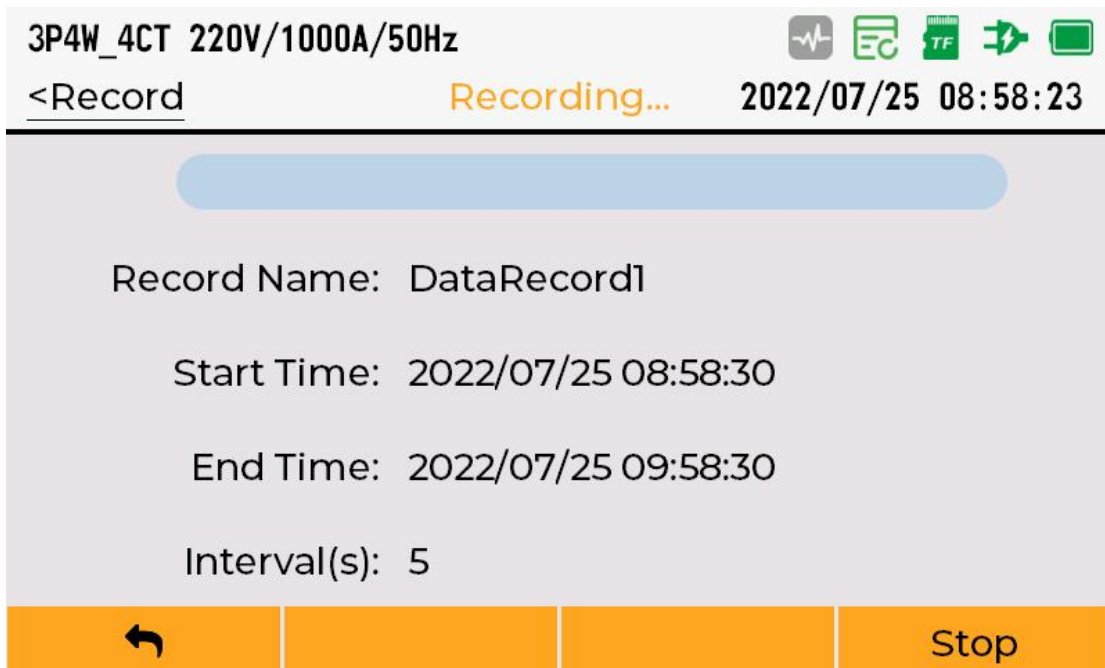

Figure 5-44 Data recorder



5.19 Waveform Recorder

Waveform Recorder is used to collect current voltage and current waveform at fixed time.

Record name: used to set the name of the record file. The maximum length is 20. The record file name will automatically include the record starting time.

Start time: used to set when recording starts. When pressing the key **F4** to start recording, if the start time is less than the current time +10 seconds, the start time will be automatically modified to the current time +10 seconds.

Sampling rate (kHz): used to set the sampling rate of waveform, which can be set to 1\2\4\8, and the corresponding maximum sampling duration is: 40s\20s\10s\5s.

Duration (s): used to set the waveform recording length. The maximum duration that can be set is different for different sampling rates.

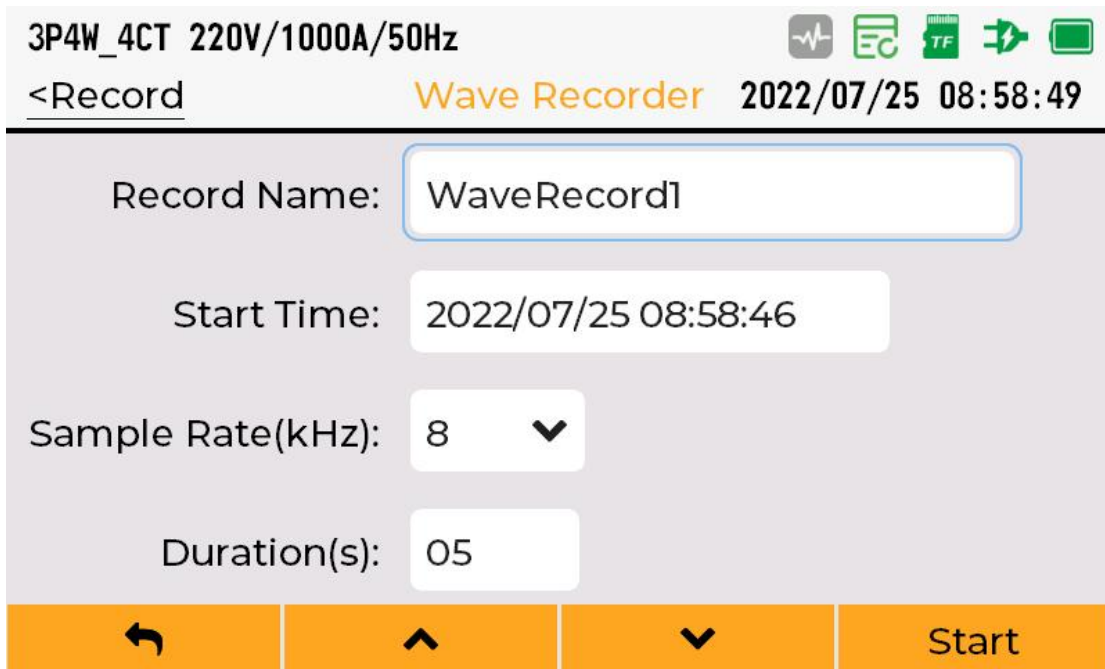

Figure 5-45 Waveform Recorder



5.20 Record management

Records management is used to export and delete records.

Record management includes basic data records, voltage harmonic records, current harmonic records, event records, waveform records, etc.

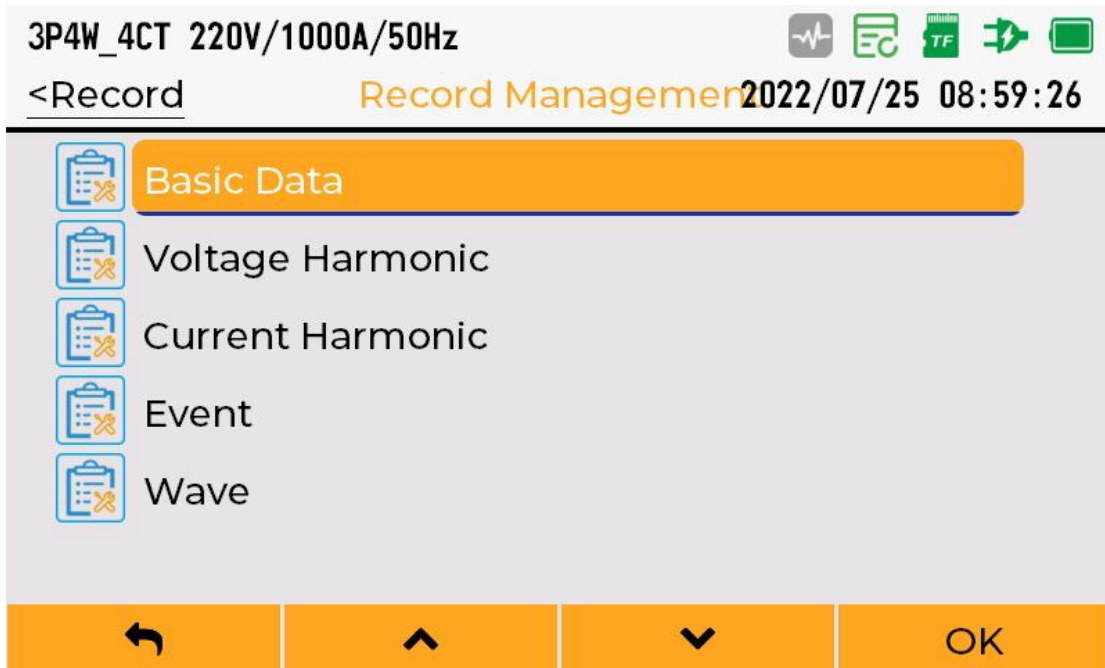

Figure 5-46 Record management

F4 The key is used to export the currently selected record. You must insert a USB flash disk before exporting the record, otherwise you cannot export data

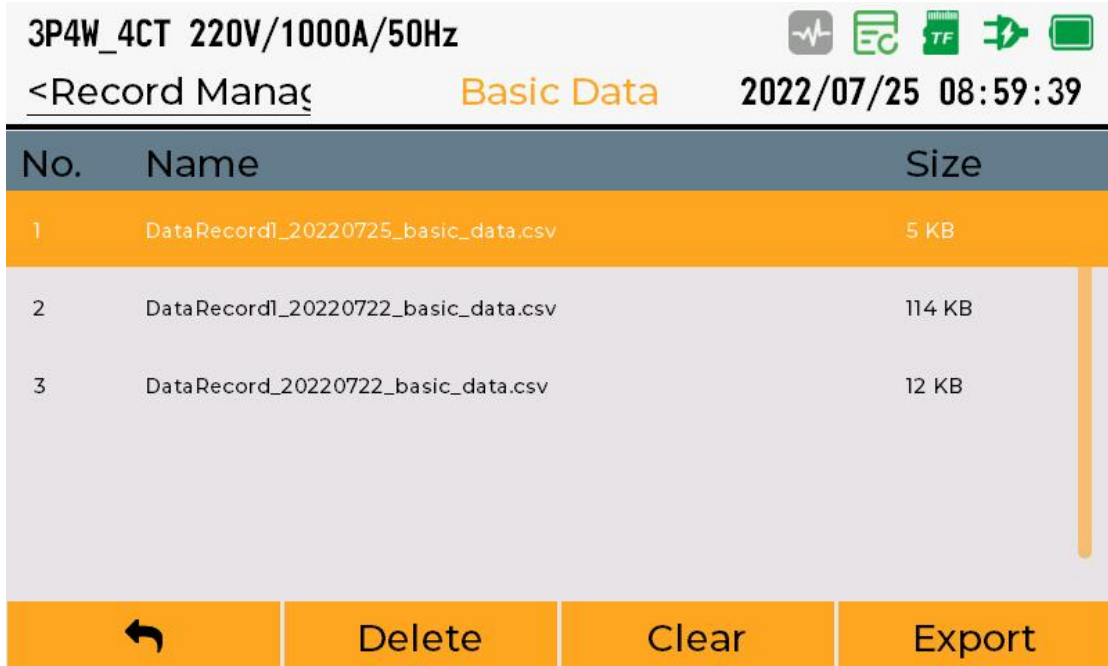

Figure 5-47 Basic data record export

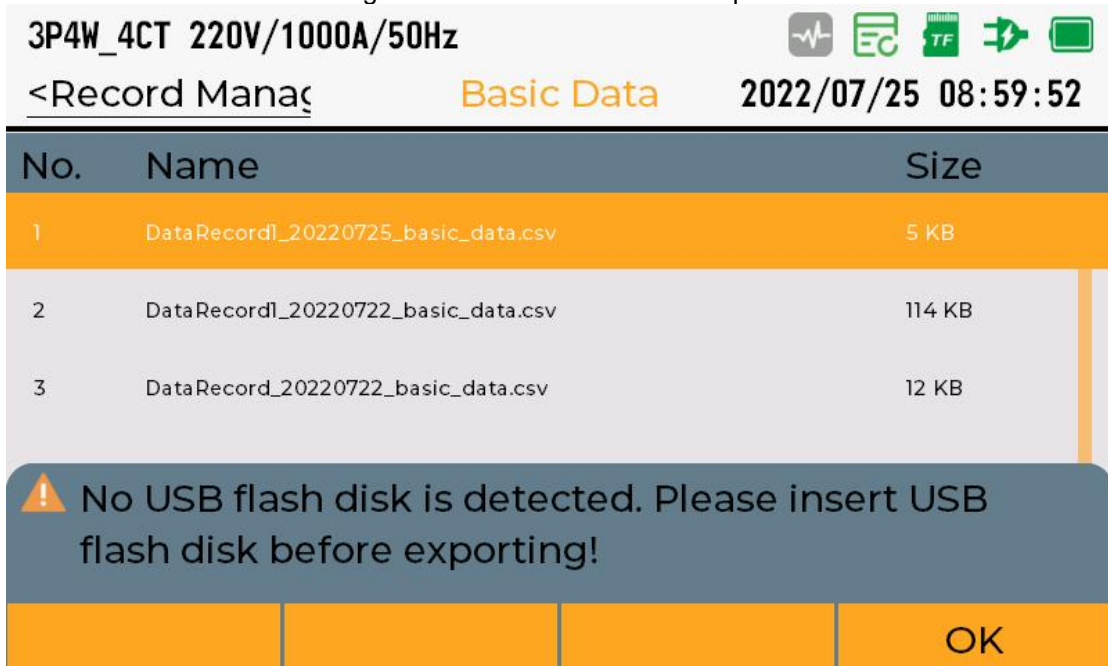

Figure 5-48 USB flash disk detection

F2 The key to delete the currently selected record.

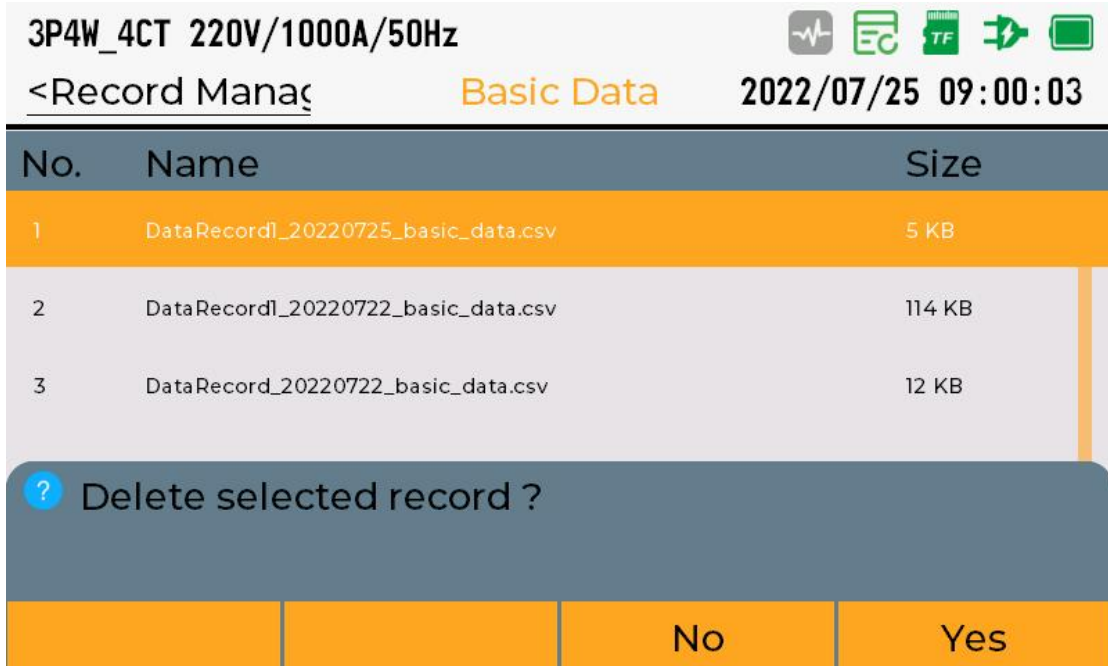

Figure 5-49 Delete current record

F3 The key is used to delete all records.

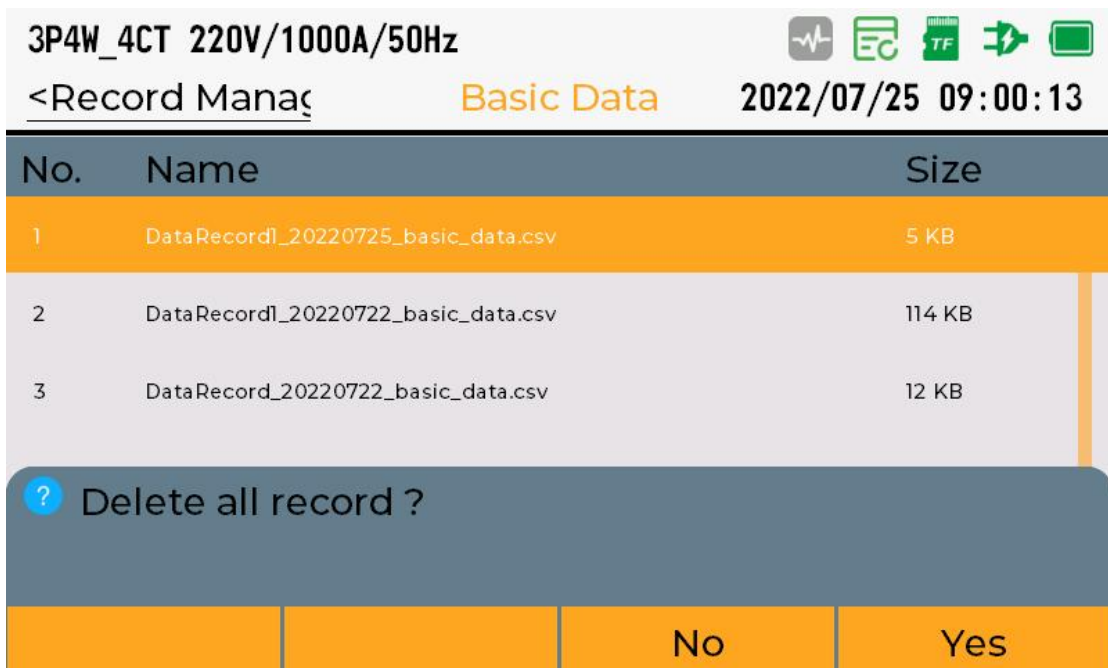

Figure 5-50 Delete all records

5.21 Storage capacity

Storage capacity is used to view the internal storage space usage and memory format.

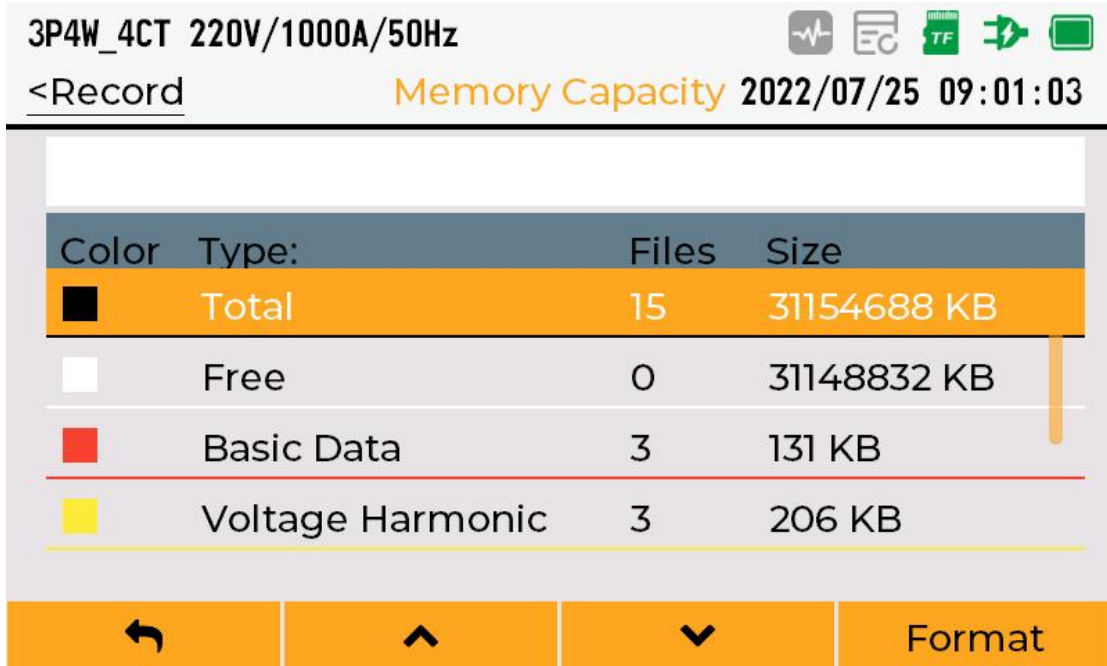

Figure 5-51 Storage capacity

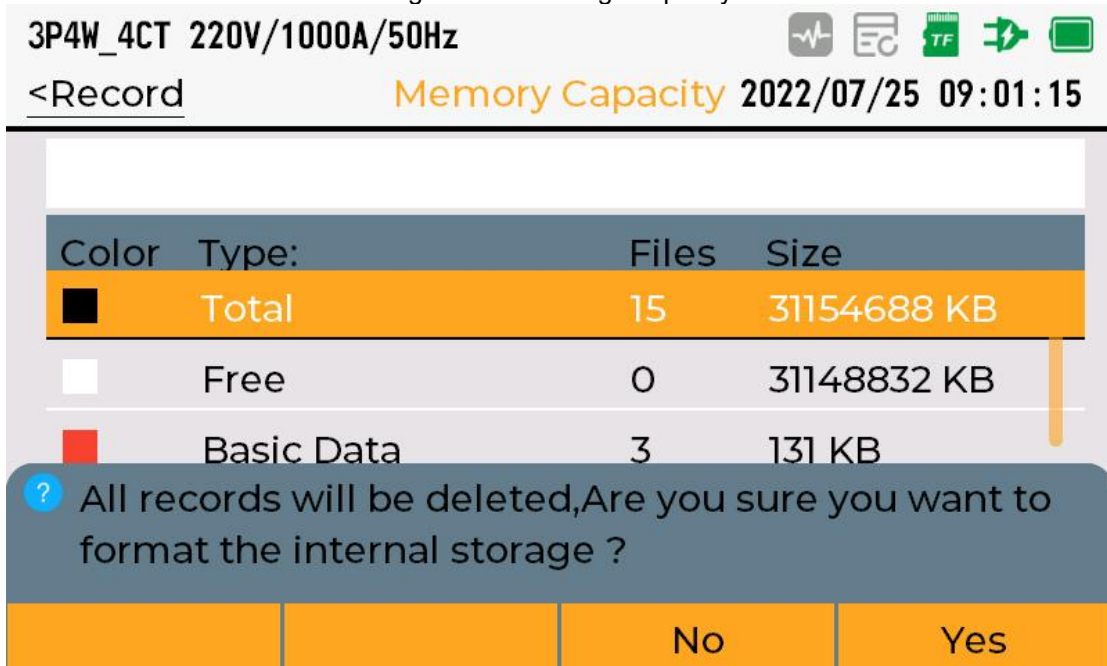

Figure 5-52 Format

6 Modbus Communication

Communication	
Communication interface	RJ45-Ethernet
Communication protocol	Modbus-TCP/IP

The analyzer is equipped with a standard RJ45 Ethernet communication interface, which can be used for Modbus TCP / IP communication, and adopting standard communication protocol Modbus TCP / IP.

Before Modbus TCP communication, the following parameters need to be set through the interface of the analyzer:

Parameter	Effective value	Default value
IP address	-	192.168.1.55
Subnet mask	-	255.255.255.0
Gateway address	-	192.168.1.1
Modbus protocol port number	-	502

6.1 Modbus-TCP/IP data frame

When transmitted over TCP / IP Ethernet, Modbus TCP / IP data frame includes 3 parts: packet header, function code and data.

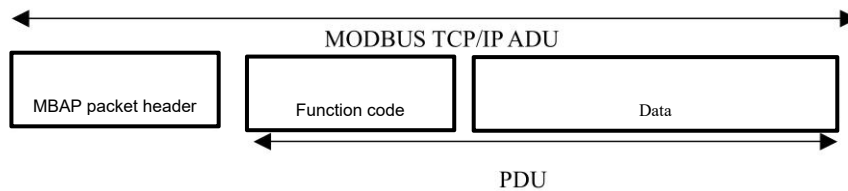

MBAP packet header (MBAP、Modbus Application Protocol、Modbus application Protocol) is divided into 4 fields with 7 bytes in total.

MBAP packet header

Field	Length	Description	Client	Server
Transaction meta identifier	2 bytes	MODBUS ID of the request / response transaction	Client startup	The server replicates from the received request.
Protocol identifier	2 bytes	0=MODBUS Protocol	Client startup	The server replicates from the received request.
Length	2 bytes	Number of bytes	Client startup (request)	Server (response) start
Unit identifier	1 byte	Identification code of remote slave station connected on serial link or other bus	Client startup	The server replicates from the received request.

The packet header is 7 bytes length:

- Transaction identifier: used for transaction pairing. In response, the Modbus server copies the transaction identifier of the request.
- Protocol identifier: used for multiplexing in the system. The Modbus protocol is identified by a value of 0.
- Length: the length field is the number of bytes of the next field, including unit identifier and data field.
- Unit identifier: this field is used for intra system routing. It is specially used for TCP-IP network and MODBUS string over Ethernet.

- The gateway between row links communicates with the slave station of Modbus or MODBUS + serial link. Modbus client is set in the request.
- This field. In the response, the server must return this field with the same value.
- PDU includes two parts: function code and data. Function code is used to distinguish functions, and data is used to explain specific meanings.

Function code	Data
8-Bits	N×8-Bits

Function codes are used to indicate how the analyzer processes the instruction. The following table shows the available function codes and their descriptions.

Function code		Name of function code	Function	Remarks
Decimal system	Hexadecimal			
3	03H	Read holding register	Used to read analyzer's parameters	
16	10H	Write multiple registers	Used to configure analyzer parameters	

6.2 Modbus-TCP/IP Function code operation instructions

6.2.1 Function code (0x03=3) operation instructions

The function code (0x03=3) is used to read the parameters of the analyzer register. Its request data and return data format are as follows:

Request data format:

Serial No.	Name	Type	Range (Decimal system)	Description
1	Transaction unit ID	UInt16		High byte first (sending sequence)
2	Protocol identifier	UInt16	0=MODBUS	High byte first (sending sequence)
3	Data byte length	UInt16		High byte first (sending sequence)
4	Unit identifier	UInt8		
5	Function code	UInt8	3	
6	The beginning register address	UInt16	-	High byte first (sending sequence)
7	Number of registers	UInt16	1-125	High byte first (sending sequence)

Return data format:

Serial No.	Name	Type	Range (Decimal system)	Description
1	Transaction unit ID	UInt16		High byte first (sending

				sequence)
2	Protocol identifier	UInt16	0=MODBUS	High byte first (sending sequence)
3	Data byte length	UInt16		High byte first (sending sequence)
4	Unit identifier	UInt8		
5	Function code	UInt8	3	
6	Read register bytes	UInt8	-	Read the number of registers*2
7	Value of register 1		-	High byte first
8	...		-	High byte first
9	Value of register n		-	High byte first

For instance:

Read the voltage values of A, B and C (the starting address of the voltage register is 1010)

Serial No.	Name	Type	Range (Decimal system)	Range (HEX)	Description
1	Transaction unit ID	UInt16	0	0000	
2	Protocol identifier	UInt16	0	0000	
3	Data byte length	UInt16	6	0006	
4	Unit identifier	UInt8	1	01	
5	Function code	UInt8	3	03	
6	The beginning register address	UInt16	1010	03F2	
7	Number of registers	UInt16	6	0006	

The sequence for sending the bytes of TCP / IP packets is as follows:

00 00 00 00 00 06 01 03 03 F2 00 06

Return data:

00 00 00 00 00 0F 01 03 0C 43 5C 00 00 43 5C 00 00 43 5C 00 00

Serial No.	Name	Type	Hexadecimal	Decimal system
1	Transaction unit ID	UInt16	0000	0
2	Protocol identifier	UInt16	0000	0
3	Data byte length	UInt16	0006	6
4	Unit identifier	UInt8	01	1
5	Function code	UInt8	03	3
6	Read register bytes	UInt8	0C	12
7	Phase A voltage	float32	435C0000	220V
8	Phase B voltage	float32	435C0000	220V
9	Phase C voltage	float32	435C0000	220V

6.2.2 Function code (0x10=16) operating instructions

Can use the function code (0x10=16) to write instructions to the analyzer and configure the analyzer parameters.

Analyzer parameter configuration can only be configured by writing the corresponding data to the "configuring instruction register", that is, writing the corresponding data to the address starting from 300 to configure the corresponding parameters.

Configuration results:

The configuration results can be read through registers 424 and 425.

Register address	Content	Size (16 bits)	Data (example)
424	Configuration instruction code	1	1001 (set time)
425	Result	1	0 = valid operation 80 = invalid instruction code 81 = invalid instruction parameter 82 = number of invalid instruction parameters 83 = operation not executed

The request and return data format of Modbus TCP is as follows:

Request data format:

Serial No.	Name	Type	Range	Description
1	Transaction unit ID	UInt16		High byte first (sending sequence)
2	Protocol identifier	UInt16	0=MODBUS	High byte first (sending sequence)
3	Data byte length	UInt16		High byte first (sending sequence)
4	Unit identifier	UInt8		
5	Function code	UInt8	16	
6	Register initial address	UInt16	300	High byte first (sending sequence)
7	Number of registers	UInt16	1-123	High byte first (sending sequence)
8	Number of register bytes	UInt8		Number of registers *2
9	Written value of register 1	UInt16	-	High byte first (sending sequence)
10	...	UInt16	-	High byte first (sending sequence)
11	Written value of register n	UInt16	-	High byte first (sending sequence)

Return data format:

Serial No.	Name	Type	Range	Description
1	Transaction unit ID	UInt16		High byte first (sending sequence)

2	Protocol identifier	UInt16	0=MODBUS	High byte first (sending sequence)
3	Data byte length	UInt16		High byte first (sending sequence)
4	Unit identifier	UInt8		
5	Function code	UInt8	16	
6	Register initial address	UInt16	300	High byte first
7	Number of registers	UInt16	1-123	High byte first

Attention!

The function code (0x10=16) can only write data to the "configuration instruction register", that is, it can only write data to the register starting from address 300.

For example:

Configure the analyzer time (command =1200, set to: 2022-7-1 12:23:25).

Serial No.	Name	Type	Value (Decimal system)	Value (HEX)	Description
1	Transaction unit ID	UInt16	0	0000	
2	Protocol identifier	UInt16	0	0000	
3	Data byte length	UInt16	21	0015	
4	Unit identifier	UInt8	1	01	
5	Function code	UInt8	16	10	
6	The beginning register address	UInt16	300	012C	Write register initial address 300
7	Number of registers	UInt16	7	0007	
8	Number of register bytes	UInt8	14	0E	
9	Register 300 written value	UInt16	1200	04B0	Set time instruction 1200
10	Register 301 written value	UInt16	2022	07E6	Year=2022
11	Register 302 written value	UInt16	7	0007	Month=7
12	Register 303 written value	UInt16	1	0001	Date=1
13	Register 304 written value	UInt16	12	000C	Hour=12
14	Register 305 written value	UInt16	23	0017	Minute=23
15	Register 306 written value	UInt16	25	0019	Second=25

The sequence for sending bytes of TCP/IP packets is as follows:

00 00 00 00 00 15 01 10 01 2C 00 07 0E 04 B0 07 E6 00 07 00 01 00 0C 00 17 00 19

If the configuration data is correct, will return to the following data:

00 00 00 00 00 06 01 10 01 2C 00 07

Serial No.	Name	Type	Range (HEX)	Range (Decimal system)
1	Transaction unit ID	UInt16	0000	0
2	Protocol identifier	UInt16	0000	0
3	Data byte length	UInt16	0006	6
4	Unit identifier	UInt8	01	1
5	Function code	UInt8	10	16
6	The beginning register address	UInt16	012C	300
7	Number of registers	UInt16	0007	7

6.2.3 Error response

Error response data format:

Serial No.	Name	Type	Decimal system	Hexadecimal	Description
1	Transaction unit ID	UInt16	0	0	
2	Protocol identifier	UInt16	0	0	
3	Data byte length	UInt16	3	0003	
4	Unit identifier	UInt8	1	01	
5	Function code	UInt8	(128+3) (128+16)	(0x80+0x03) (0x80+0x10)	
6	Error code	UInt8			

Modbus Error code:

Code (HEX)	Name	Meaning
0x01	Illegal function code	The function code supported by the analyzer is not used.
0x02	Illegal data address	The register data written or read is not a supported address range.
0x03	Illegal data value	The data value written to the register does not meet the requirements.
0x04	Analyzer error	An unknown error occurred

7 List of configuration instructions

System parameter setting:

Instruction code	Operation	Size	Type	Unit	Range (Decimal system)	Description
1001	W	1	UInt16	-	0,1,2,3,4	Wiring mode 0=3P4W_4CT 1=3P4W_3CT 2=3P3W_3CT 3=3P3W_2CT

Instruction code	Operation	Size	Type	Unit	Range (Decimal system)	Description
						4=1P2W
	W	1	UInt16	Hz	50,60	Grid frequency
	W	2	UInt32	V	1-99999	Nominal voltage

Parameter setting of phase ABC current transformer:

Instruction code	Operation	Size	Type	Unit	Range (Decimal system)	Description
1002	W	1	UInt16	-	0,1	Phase ABC current access mode 0 = Rogowski coil access 1 = CT access
	W	2	UInt32	mV/kA @50Hz	1-99999	Phase ABC Rogowski coil sensitivity =Actual value*100
	W	2	UInt32	A	1-99999	Nominal current of phase ABC Rogowski coil
	W	2	UInt32	-	1-99999999	Current transformation ratio of phase ABC Rogowski coil =Actual transformation ratio *10000
	W	2	UInt32	mV/A	1-999999	CT sensitivity of phase ABC =Actual value *100
	W	2	UInt32	A	1-999999	CT nominal current of phase ABC
	W	2	UInt32	-	1-99999999	CT current transformation ratio of phase ABC = Actual transformation ratio *10000

Parameter setting of N-phase current transformer:

Instruction code	Operation	Size	Type	Unit	Range (Decimal system)	Description
1003	W	1	UInt16	-	0,1	N-phase current access mode 0 = Rogowski coil access 1 = CT access
	W	2	UInt32	mV/kA @50Hz	1-99999	N-phase Rogowski coil sensitivity =Actual value*100
	W	2	UInt32	A	1-99999	Nominal current of N-phase Rogowski coil

Instruction code	Operation	Size	Type	Unit	Range (Decimal system)	Description
	W	2	UInt32	-	1-99999999	Current transformation ratio of N-phase Rogowski coil =Actual transformation ratio *10000
	W	2	UInt32	mV/A	1-999999	N-phase CT sensitivity =Actual value *100
	W	2	UInt32	A	1-999999	Nominal current of N-phase CT
	W	2	UInt32	-	1-99999999	N-phase CT current transformation ratio =Actual transformation ratio *10000

Voltage transformer parameter setting:

Instruction code	Operation	Size	Type	Unit	Range (Decimal system)	Description
1005	W	2	UInt32	-	1-99999999	Transformation ratio of phase ABC voltage transformer =Actual transformation ratio *10000
	W	2	UInt32	-	1-99999999	Transformation ratio of N-phase voltage transformer =Actual transformation ratio *10000

Voltage swell and dip, interruption event threshold setting:

Instruction code	Operation	Size	Type	Unit	Range (Decimal system)	Description
1050	W	1	UInt16	%	1050~1400	Voltage swell threshold Nominal voltage as reference Magnify in 10 times Default value: 1100
	W	1	UInt16	%	10~60	Voltage swell hysteresis value Nominal voltage as reference Magnify in 10 times Default value: 20
	W	1	UInt16	%	750~950	Voltage dip threshold Nominal voltage as reference Magnify in 10 times Default value: 90

Instruction code	Operation	Size	Type	Unit	Range (Decimal system)	Description
	W	1	UInt16	%	10~60	Voltage dip hysteresis value Nominal voltage as reference Magnify in 10 times Default value: 20
	W	1	UInt16	%	10~100	Voltage interruption threshold Nominal voltage as reference Magnify in 10 times Default value: 50
	W	1	UInt16	%	10~60	Voltage interruption hysteresis value Nominal voltage as reference Magnify in 10 times Default value: 20

Over frequency low frequency event threshold setting:

Instruction code	Operation	Size	Type	Unit	Range (Decimal system)	Description
1051	W	1	UInt16	%	1001~1200	Overfrequency threshold Nominal frequency as reference Magnify in 10 times Default value: 1010
	W	1	UInt16	%	500~999	Low frequency threshold Nominal frequency as reference Magnify in 10 times Default value: 990

Overvoltage and low voltage event threshold setting:

Instruction code	Operation	Size	Type	Unit	Range (Decimal system)	Description
1052	W	1	UInt16	%	10100~20000	Overvoltage threshold Nominal voltage as reference Magnify in 100 times Default value: 11000
	W	1	UInt16	%	100~9900	Low voltage threshold Nominal voltage as reference Magnify in 100 times Default value: 9000

Overcurrent low current event threshold setting:

Instruction code	Operation	Size	Type	Unit	Range (Decimal system)	Description
1053	W	1	UInt16	%	10100~20000	Overcurrent threshold Nominal current as reference Magnify in 100 times Default value: 11000
	W	1	UInt16	%	100~9900	Low current threshold Nominal current as reference Magnify in 100 times Default value: 9000

Unbalance degree event threshold setting:

Instruction code	Operation	Size	Type	Unit	Range (Decimal system)	Description
1054	W	1	UInt16	%	1~9999	Voltage unbalance degree threshold Magnify in 100 times Default value: 400
	W	1	UInt16	%	1~9999	Current unbalance degree threshold Magnify in 100 times Default value: 1000

Voltage harmonic event threshold setting:

Instruction code	Operation	Size	Type	Unit	Range (Decimal system)	Description
1055	W	1	UInt16	%	1~9999	Voltage total harmonic threshold Magnify in 100 times Default value: 500
	W	1	UInt16	%	1~9999	Voltage even harmonic threshold Magnify in 100 times Default value: 500
	W	1	UInt16	%	1~9999	Voltage odd harmonic threshold Magnify in 100 times Default value: 500

Current harmonic event threshold setting:

Instruction code	Operation	Size	Type	Unit	Range (Decimal system)	Description
------------------	-----------	------	------	------	------------------------	-------------

Instruction code	Operation	Size	Type	Unit	Range (Decimal system)	Description
1056	W	1	UInt16	%	1~9999	Current total harmonic threshold Magnify in 100 times Default value: 500
	W	1	UInt16	%	1~9999	Current even harmonic threshold Magnify in 100 times Default value: 500
	W	1	UInt16	%	1~9999	Current odd harmonic threshold Magnify in 100 times Default value: 500

Demand parameter setting:

Instruction code	Operation	Size	Type	Unit	Range (Decimal system)	Description
1060	W	1	UInt16	-	0,1	Demand calculation method 0= fixed 1= sliding type
	W	1	UInt16	分钟	1-60	Demand calculation interval

Zero drift suppression setting:

Instruction code	Operation	Size	Type	Unit	Range (Decimal system)	Description
1070	W	1	UInt16	%	0~1000	Voltage zero drift suppression of phase ABC Nominal voltage as reference Magnify in 100 times Default value: 30
	W	1	UInt16	%	0~1000	Voltage zero drift suppression of N-phase Nominal voltage as reference Magnify in 100 times Default value: 30
	W	1	UInt16	%	0~1000	Current zero drift suppression of phase ABC Nominal current as reference Magnify in 100 times Default value: 50
	W	1	UInt16	%	0~1000	Current zero drift

Instruction code	Operation	Size	Type	Unit	Range (Decimal system)	Description
						suppression of N-phase Take nominal current as reference Magnify in 100 times Default value: 50

Harmonic calculation threshold setting:

Instruction code	Operation	Size	Type	Unit	Range (Decimal system)	Description
1080	W	1	UInt16	%	0~1000	Voltage harmonic calculation threshold of phase ABC Nominal voltage as reference Magnify in 100 times Default value: 300
	W	1	UInt16	%	0~1000	Current harmonic calculation threshold of phase ABC Nominal current as reference Magnify in 100 times Default value: 500

CO2 emission factor setting:

Instruction code	Operation	Size	Type	Unit	Range (Decimal system)	Description
1090	W	1	UInt32	kgCO2/MWh	0~999999	CO2 emission factor Magnify in 100 times Default value: 60000

Analyzer time setting:

Instruction code	Operation	Size	Type	Unit	Range (Decimal system)	Description
1200	W	1	UInt16	-	2000-2099	Year
	W	1	UInt16	-	1-12	Month
	W	1	UInt16	-	1-31	Date
	W	1	UInt16	-	0-23	Hour
	W	1	UInt16	-	0-59	Minute
	W	1	UInt16	-	0-59	Second

Restore factory settings:

Instruction code	Operation	Size	Type	Unit	Range (Decimal system)	Description
1300	W	1	UInt16	-	1	1: Restore factory settings

Energy reset:

Instruction code	Operation	Size	Type	Unit	Range (decimal)	Description
1301	W	1	UInt16	-	1	1: Energy reset

Peak demand reset:

Instruction code	Operation	Size	Type	Unit	Range (decimal)	Description
1302	W	1	UInt16	-	1	1: Peak demand reset

Restart the analyzer:

Instruction code	Operation	Size	Type	Unit	Range (decimal)	Description
6000	W	1	UInt16	-	6485	Restart analyzer command

8 Register list

The register list has the following headings:

Register alias	Register address	Operation read / write	Size	Type	Unit	Description
----------------	------------------	------------------------	------	------	------	-------------

- Register alias: Used to refer to the meaning of registers
- Register address: The initial address of Modbus communication register is in decimal format, and the address is the real address without offset.
- Operation: Indicates the operation that the register can perform, R: readable; W: It can be written directly through 16 function code; WC: the current register needs to be configured indirectly by writing configuration data to the address starting from the instruction register 300.
- Size: Indicates how many MODBUS registers are occupied. One MODBUS register is 16bit.
- Type: For the type of data code, see the Data type table
- Unit: Unit of register value
- Description: Introduce the function of this register.

Data type table

Type	Description	Range
------	-------------	-------

Type	Description	Range
UInt16	Unsigned 16 bits integer	0~65535
Int16	Signed 16 bits integer	-32768~+32767
UInt32	Unsigned 32-bit integer	0~4294967295
UInt64	Unsigned 64 bits integer	0~18446744073709551615
Int64	Signed 64 bits integer	-9223372036854775808 ~ 9223372036854775808
UTF8	8-bit UTF code	Multibyte Unicode encoding
Float32	32-bit floating point	Standard IEEE floating point data (single precision)
Date Time	Time type	-
IPAddr	IP address	

Date Time format

字	位															
	15	14	13	12	11	10	9	8	7	6	5	4	3	2	1	0
1	Year (2000–2099)															
2	Month (1–12)								Date (1–31)							
3	Hour (0–23)								Minute (0–59)							
4	Millisecond (0–59999)															

IPAddr format

Byte	Position															
	15	14	13	12	11	10	9	8	7	6	5	4	3	2	1	0
1	addr1(0–255)								addr2(0–255)							
2	addr3(0–255)								addr4(0–255)							

For instance: 192.168.1.5

Byte	Position															
	15	14	13	12	11	10	9	8	7	6	5	4	3	2	1	0
1	192								168							
2	1								55							

8.1 Modbus Register list

Configure instruction register

Register alias	Register initial address (decimal)	Operation Read / write	Size	Type	Unit	Description
Instruction code	300	R/W	1	UInt16	-	

Register alias	Register initial address (decimal)	Operation Read / write	Size	Type	Unit	Description
Instruction parameters001	301	R/W	1	UInt16	-	
Instruction parameters002	302	R/W	1	UInt16	-	
...	...	R/W	1	UInt16	-	
Instruction parameters123	423	R/W	1	UInt16	-	
Configuration instruction code	424	R	1	UInt16	-	
Configuration results	425	R	1	UInt16	-	0 = valid operation 80 = invalid instruction code 81 = invalid instruction parameter 82 = number of invalid instruction parameters 83= operation not executed

Equipment parameters:

Register alias	Register initial address (decimal)	Operation read / write	Size	Type	Unit	Description
Analyzer model	60	R	5	UTF8	-	
Serial No.	70	R	2	UInt32	-	
APP Version No.	72	R	1	UInt16	-	Format: X.Y.Z
IAP Version No.	73	R	1	UInt16	-	Format: X.Y.Z
Hardware version No.	74	R	1	UInt16	-	Format: ab.c :xy.z
Date and time	75	R/WC	4	Date time	-	Reg.75: Year 2000-2099 Reg.76: Month (b15:b8), 日 (b7:b0) Reg. 77: Hour (b15:b8), 分 (b7:b0) Reg. 78: Millisecond

Power system:

Register alias	Register initial address (decimal)	Operation read / write	Size	Type	Unit	Description
Wiring mode	500	R/WC	1	UInt16	-	0=3P4W_4CT 1=3P4W_3CT 2=3P3W_3CT 3=3P3W_2CT 4=1P2W
Grid frequency	501	R/WC	1	UInt16	Hz	
Nominal voltage	502	R/WC	2	UInt32	V	
Phase ABC current transformer						
Phase ABC current access mode	504	R/WC	1	UInt16	-	0 = Rogowski coil 1 = CT
Phase ABC Rogowski coil sensitivity	505	R/WC	2	UInt32	mV/kA @50Hz	Actual value = read value /100
Nominal current of phase ABC Rogowski coil	507	R/WC	2	UInt32	A	
Current transformation ratio of phase ABC Rogowski coil	509	R/WC	2	UInt32	-	Actual value = read value/10000
CT sensitivity of phase ABC	511	R/WC	2	UInt32	mV/A	Actual value = read value/100
CT nominal current of phase ABC	513	R/WC	2	UInt32	A	
CT current transformation ratio of phase ABC	515	R/WC	2	UInt32	-	Actual value = read value/10000
N-phase current transformer						
N-phase current access mode	517	R/WC	1	UInt16	-	0 = Rogowski coil 1 = CT
N-phase Rogowski coil sensitivity	518	R/WC	2	UInt32	mV/kA @50Hz	Actual value = read value/100
Nominal current of N-phase Rogowski coil	520	R/WC	2	UInt32	A	
Current transformation ratio of N-phase Rogowski coil	522	R/WC	2	UInt32	-	Actual value = read value/10000
CT sensitivity of N-phase	524	R/WC	2	UInt32	mV/A	Actual value = read value/100
CT nominal current of N-phase	526	R/WC	2	UInt32	A	
CT current transformation ratio of N-phase	528	R/WC	2	UInt32	-	Actual value = read value/10000

Register alias	Register initial address (decimal)	Operation read / write	Size	Type	Unit	Description
Voltage transformer						
Transformation ratio of phase ABC voltage transformer	530	R/WC	2	UInt32	-	Actual value = read value/10000
Transformation ratio of N-phase voltage transformer	532	R/WC	2	UInt32	-	Actual value = read value/10000

Basic data:

Voltage, current, power, power factor:

Register alias	Register initial address (decimal)	Operation read / write	Size	Type	Unit	Description
Current						
IA	1000	R	2	Float32	A	Phase A current
IB	1002	R	2	Float32	A	Phase B current
IC	1004	R	2	Float32	A	Phase C current
IN	1006	R	2	Float32	A	Phase N current
Current Avg	1008	R	2	Float32	A	Average value of ABC three-phase current
Phase voltage						
UA	1010	R	2	Float32	V	UA-UN voltage
UB	1012	R	2	Float32	V	UB-UN voltage
UC	1014	R	2	Float32	V	UC-UN voltage
UN-G	1016	R	2	Float32	V	UN-GND voltage
Phase Voltage Avg	1018	R	2	Float32	V	Average value of ABC three-phase phase voltage
Line voltage						
UAB	1020	R	2	Float32	V	UA-UB voltage
UBC	1022	R	2	Float32	V	UB-UC voltage
UCA	1024	R	2	Float32	V	UC-UA voltage
Line Voltage Avg	1026	R	2	Float32	V	Average value of three-phase line voltage
Active power						
PA	1028	R	2	Float32	kW	Phase A Active power
PB	1030	R	2	Float32	kW	Phase B Active power
PC	1032	R	2	Float32	kW	Phase C Active power
PTotal	1034	R	2	Float32	kW	Total Active power

Register alias	Register initial address (decimal)	Operation read / write	Size	Type	Unit	Description
Reactive power						
QA	1036	R	2	Float32	kVAR	Phase A Reactive power
QB	1038	R	2	Float32	kVAR	Phase B Reactive power
QC	1040	R	2	Float32	kVAR	Phase C Reactive power
QTotal	1042	R	2	Float32	kVAR	Total Reactive power
Apparent power						
SA	1044	R	2	Float32	kVA	Phase A Apparent power
SB	1046	R	2	Float32	kVA	Phase B Apparent power
SC	1048	R	2	Float32	kVA	Phase C Apparent power
STotal	1050	R	2	Float32	kVA	Total Apparent power
Power factor						
PFA	1052	R	2	Float32	-	Phase A Power factor
PFB	1054	R	2	Float32	-	Phase B Power factor
PFC	1056	R	2	Float32	-	Phase C Power factor
PFTotal	1058	R	2	Float32	-	Total Power factor
Fundamental harmonic power factor						
DPFA	1060	R	2	Float32	-	Phase A Fundamental harmonic power factor
DPFB	1062	R	2	Float32	-	Phase B Fundamental harmonic power factor
DPFC	1064	R	2	Float32	-	Phase C Fundamental harmonic power factor
DPFTotal	1066	R	2	Float32	-	Total Fundamental harmonic power factor
Frequency						
FreqA	1068	R	2	Float32	Hz	Phase A Frequency
FreqB	1070	R	2	Float32	Hz	Phase B Frequency
FreqC	1072	R	2	Float32	Hz	Phase C Frequency
FreqTotal	1074	R	2	Float32	Hz	Three phase comprehensive frequency

Energy:

There are two types of energy, possive energy and reverse energy.

When the total electric energy reaches 1.0×10^9 kwh, 1.0×10^9 kvarh, or 1.0×10^9 KVAh, the electric energy of each phase will be cleared automatically.

Register alias	Register initial address (decimal)	Operation read / write	Size	Type	Unit	Description
----------------	------------------------------------	------------------------	------	------	------	-------------

Register alias	Register initial address (decimal)	Operation read / write	Size	Type	Unit	Description
Active Energy						
EPAlmp	2500	R	4	Int64	Wh	Phase A Positive active energy
EPBlmp	2504	R	4	Int64	Wh	Phase B Positive active energy
EPClmp	2508	R	4	Int64	Wh	Phase C Positive active energy
EPImp	2512	R	4	Int64	Wh	Total Positive active energy
EPAExp	2516	R	4	Int64	Wh	Phase A Reverse active energy
EPBExp	2520	R	4	Int64	Wh	Phase B Reverse active energy
EPCExp	2524	R	4	Int64	Wh	Phase C Reverse active energy
EPEExp	2528	R	4	Int64	Wh	Total Reverse active energy
Reactive energy						
EQAlmp	2532	R	4	Int64	Wh	Phase A Positive reactive energy
EQBlmp	2536	R	4	Int64	Wh	Phase B Positive reactive energy
EQClmp	2540	R	4	Int64	Wh	Phase C Positive reactive energy
EQIimp	2544	R	4	Int64	Wh	Total Positive reactive energy
EQAExp	2548	R	4	Int64	Wh	Phase A Reverse reactive energy
EQBExp	2552	R	4	Int64	Wh	Phase B Reverse reactive energy
EQCExp	2556	R	4	Int64	Wh	Phase C Reverse reactive energy
EQExp	2560	R	4	Int64	Wh	Total Reverse reactive energy
Apparent Energy						
ESA	2564	R	4	Int64	VAh	Phase A Apparent Energy
ESB	2568	R	4	Int64	VAh	Phase B Apparent Energy
ESC	2572	R	4	Int64	VAh	Phase C Apparent Energy
ES	2576	R	4	Int64	VAh	Total Apparent Energy

Demand register:

Register alias	Register initial address (decimal)	Operation read / write	Size	Type	Unit	Description
Basic parameters of demand						
DMDMethod	3000	R/WC	1	UInt16	-	Demand calculation method: 0= sliding type 1= fixed
DMD block	3001	R/RC	1	UInt16	Minute	Demand interval

Register alias	Register initial address (decimal)	Operation read / write	Size	Type	Unit	Description
PDMD Reset Time	3002	R	4	Date time	-	Peak demand reset date and time
Power demand						
PADemand	3020	R	2	Float32	kW	Current active power demand of phase A
PAPeakDemand	3022	R	2	Float32	kW	Peak demand of phase A active power
PAPeakDemandDate	3024	R	4	Date time	-	Occurrence time of peak demand of phase A active power
PBDemand	3028	R	2	Float32	kW	Current active power demand of phase B
PBPeakDemand	3030	R	2	Float32	kW	Peak demand of phase B active power
PBPeakDemandDate	3032	R	4	Date time	-	Occurrence time of peak demand of phase B active power
PCDemand	3036	R	2	Float32	kW	Current active power demand of phase C
PCPeakDemand	3038	R	2	Float32	kW	Peak demand of phase C active power
PCPeakDemandDate	3040	R	4	Date time	-	Occurrence time of peak demand of phase C active power
PSUMDemand	3044	R	2	Float32	kW	Current total active power demand
PSUMPeakDemand	3046	R	2	Float32	kW	Peak demand of total active power
PSUMPeakDemandDate	3048	R	4	Date time	-	Occurrence time of peak demand of total active power
QADemand	3052	R	2	Float32	kVar	Current reactive power demand of phase A
QAPeakDemand	3054	R	2	Float32	kVar	Peak demand of phase A reactive power
QAPeakDemandDate	3056	R	4	Date time	-	Occurrence time of peak demand of phase A reactive power
QBDemand	3060	R	2	Float32	kVar	Current reactive power demand of phase B
QBPeakDemand	3062	R	2	Float32	kVar	Peak demand of phase B reactive power
QBPeakDemandDate	3064	R	4	Date time	-	Occurrence time of peak demand of phase B reactive power
QCDemand	3068	R	2	Float32	kVar	Current reactive power demand of phase C

Register alias	Register initial address (decimal)	Operation read / write	Size	Type	Unit	Description
QCPeakDemand	3070	R	2	Float32	kVar	Peak demand of phase C reactive power
QCPeakDemandDate	3072	R	4	Date time	-	Occurrence time of peak demand of phase C reactive power
QSUMDemand	3076	R	2	Float32	kVar	Current total reactive power demand
QSUMPeakDemand	3078	R	2	Float32	kVar	Peak demand of total reactive power
QSUMPeakDemandDate	3080	R	4	Date time	-	Occurrence time of peak demand of total reactive power
SADemand	3084	R	2	Float32	kVa	Current apparent power demand of phase A
SAPeakDemand	3086	R	2	Float32	kVa	Peak demand of phase A apparent power
SAPeakDemandDate	3088	R	4	Date time	-	Occurrence time of peak demand of phase A apparent power
SBDemand	3092	R	2	Float32	kVa	Current apparent power demand of phase B
SBPeakDemand	3094	R	2	Float32	kVa	Peak demand of phase B apparent power
SBPeakDemandDate	3096	R	4	Date time	-	Occurrence time of peak demand of phase B apparent power
SCDemand	3100	R	2	Float32	kVa	Current apparent power demand of phase C
SCPeakDemand	3102	R	2	Float32	kVa	Peak demand of phase C apparent power
SCPeakDemandDate	3104	R	4	Date time	-	Occurrence time of peak demand of phase C apparent power
SSUMDemand	3108	R	2	Float32	kVa	Current total apparent power demand
SSUMPeakDemand	3110	R	2	Float32	kVa	Peak demand of total apparent power
SSUMPeakDemandDate	3112	R	4	Date time	-	Occurrence time of peak demand of total apparent power
Current demand						
IADemand	3116	R	2	Float32	A	Phase A current demand
IAPeakDemand	3118	R	2	Float32	A	Peak demand of phase A current
IAPeakDemandDate	3120	R	4	Date time	-	Occurrence time of peak demand of phase A current

Register alias	Register initial address (decimal)	Operation read / write	Size	Type	Unit	Description
IBDemand	3124	R	2	Float32	A	Phase B current demand
IBPeakDemand	3126	R	2	Float32	A	Peak demand of phase B current
IBPeakDemandDate	3128	R	4	Date time	-	Occurrence time of peak demand of phase B current
ICDemand	3132	R	2	Float32	A	Phase C current demand
ICPeakDemand	3134	R	2	Float32	A	Peak demand of phase C current
ICPeakDemandDate	3136	R	4	Date time	-	Occurrence time of peak demand of phase C current
IAvgDemand	3140	R	2	Float32	A	Three phase average current demand
IAvgPeakDemand	3142	R	2	Float32	A	Peak demand of three-phase average current
IAvgPeakDemand Date	3144	R	4	Date time	-	Occurrence time of peak demand of three-phase average current

Voltage and current harmonic register:

Register name	Register initial address (decimal)	Operation	Size	Type	Unit	Description
Current harmonic percentage						
IATHD	4000	R	2	Float32	%	Phase A current total harmonic percentage
IBTHD	4002	R	2	Float32	%	Phase B current total harmonic percentage
ICTHD	4004	R	2	Float32	%	Phase C current total harmonic percentage
IATOH	4006	R	2	Float32	%	Phase A current odd total harmonic percentage
IBTOH	4008	R	2	Float32	%	Phase B current odd total harmonic percentage
ICTOH	4010	R	2	Float32	%	Phase C current odd total harmonic percentage
IATEH	4012	R	2	Float32	%	Phase A current even total harmonic percentage
IBTEH	4014	R	2	Float32	%	Phase B current even total harmonic percentage
ICTEH	4016	R	2	Float32	%	Phase C current even total harmonic percentage
IAHD1	4018	R	2	Float32	%	1st harmonic percentage of phase A current

Register name	Register initial address (decimal)	Operation	Size	Type	Unit	Description
IBHD1	4020	R	2	Float32	%	1st harmonic percentage of phase B current
ICHD1	4022	R	2	Float32	%	1st harmonic percentage of phase C current
...	4024-4311	The 2nd-49th harmonic percentage of ABC phase current
IAHD50	4312	R	2	Float32	%	The 50th harmonic percentage of phase A current
IBHD50	4314	R	2	Float32	%	The 50th harmonic percentage of phase B current
ICHD50	4316	R	2	Float32	%	The 50th harmonic percentage of phase C current
Current harmonic value						
IAHDV1	4400	R	2	Float32	A	Fundamental current value of phase A current
IBHDV1	4402	R	2	Float32	A	Fundamental current value of phase B current
ICHDV1	4404	R	2	Float32	A	Fundamental current value of phase C current
...	4406-4693	The 2nd-49th harmonic current value of ABC phase current
IAHDV50	4694	R	2	Float32	A	The 50th harmonic current value of phase A current
IBHDV50	4696	R	2	Float32	A	The 50th harmonic current value of phase B current
ICHDV50	4698	R	2	Float32	A	The 50th harmonic current value of phase C current
Voltage harmonic percentage						
UATHD	5000	R	2	Float32	%	Phase A voltage total harmonic percentage
UBTHD	5002	R	2	Float32	%	Phase B voltage total harmonic percentage
UCTHD	5004	R	2	Float32	%	Phase C voltage total harmonic percentage
UATOHD	5006	R	2	Float32	%	Phase A voltage odd total harmonic percentage
UBTOHD	5008	R	2	Float32	%	Phase B voltage odd total harmonic percentage
UCTOHD	5010	R	2	Float32	%	Phase C voltage odd total harmonic percentage
UATEHD	5012	R	2	Float32	%	Phase A voltage even total harmonic percentage
UBTEHD	5014	R	2	Float32	%	Phase B voltage even total harmonic percentage
UCTEHD	5016	R	2	Float32	%	Phase C voltage even total harmonic percentage

Register name	Register initial address (decimal)	Operation	Size	Type	Unit	Description
UAHD1	5018	R	2	Float32	%	The 1st harmonic percentage of phase A voltage
UBHD1	5020	R	2	Float32	%	The 1st harmonic percentage of phase B voltage
UCHD1	5022	R	2	Float32	%	The 1st harmonic percentage of phase C voltage
...	5024-5311	The 2nd-49th harmonic percentage of ABC phase voltage
UAHD50	5312	R	2	Float32	%	The 50th harmonic percentage of phase A voltage
UBHD50	5314	R	2	Float32	%	The 50th harmonic percentage of phase B voltage
UCHD50	5316	R	2	Float32	%	The 50th harmonic percentage of phase C voltage
Voltage harmonic value						
UAHDV1	5400	R	2	Float32	V	The 1st harmonic voltage value of phase A voltage
UBHDV1	5402	R	2	Float32	V	The 1st harmonic voltage value of phase B voltage
UCHDV1	5404	R	2	Float32	V	The 1st harmonic voltage value of phase C voltage
...	5406-5693	The 2nd-49th harmonic voltage value of ABC phase voltage
UAHDV50	5694	R	2	Float32	V	The 50th harmonic voltage value of phase A voltage
UBHDV50	5696	R	2	Float32	V	The 50th harmonic voltage value of phase B voltage
UCHDV50	5698	R	2	Float32	V	The 50th harmonic voltage value of phase C voltage

Unbalance degree:

Register name	Register initial address (decimal)	Operation	Size	Type	Unit	Description
Voltage negative sequence unbalance degree	7000	R	2	Float32	%	Voltage negative sequence unbalance degree
Voltage zero sequence unbalance degree	7002	R	2	Float32	%	Voltage zero sequence unbalance degree

Register name	Register initial address (decimal)	Operation	Size	Type	Unit	Description
Current negative sequence unbalance degree	7004	R	2	Float32	%	Current negative sequence unbalance degree
Current zero sequence unbalance degree	7006	R	2	Float32	%	Current zero sequence unbalance degree

Current K-factor and crest factor register:

Register name	Register initial address (decimal)	Operation	Size	Type	Unit	Description
Current K factor						
KFIA	8000	R	2	Float32	-	Current K factor of phase A
KFIB	8002	R	2	Float32	-	Current K factor of phase B
KFIC	8004	R	2	Float32	-	Current K factor of phase C
Current crest factor						
CFIA	8010	R	2	Float32	-	Current crest factor of phase A
CFIB	8012	R	2	Float32	-	Current crest factor of phase B
CFIC	8014	R	2	Float32	-	Current crest factor of phase C
Voltage crest factor						
CFUA	8020	R	2	Float32	-	Voltage crest factor of phase A
CFUB	8022	R	2	Float32	-	Voltage crest factor of phase B
CFUC	8024	R	2	Float32	-	Voltage crest factor of phase C

Voltage and current angle register:

Register name	Register initial address (decimal)	Operation	Size	Type	Unit	Description
Angle between voltages:						
UAB	8100	R	2	Float32	°	Angle between phase A and phase B voltage
UBC	8102	R	2	Float32	°	Angle between phase B and phase C voltage
UCA	8104	R	2	Float32	°	Angle between phase C and phase A voltage
Angle between currents:						

Register name	Register initial address (decimal)	Operation	Size	Type	Unit	Description
IAB	8106	R	2	Float32	°	Angle between phase A and phase B current
IBC	8108	R	2	Float32	°	Angle between phase B and phase C current
ICA	8110	R	2	Float32	°	Angle between phase C and phase A current
Angle between voltage and current:						
UIA	8112	R	2	Float32	°	Angle between voltage and current of phase A
UIB	8114	R	2	Float32	°	Angle between voltage and current of phase B
UIC	8116	R	2	Float32	°	Angle between voltage and current of phase C

9 Operation interface topology

9.1 Setup

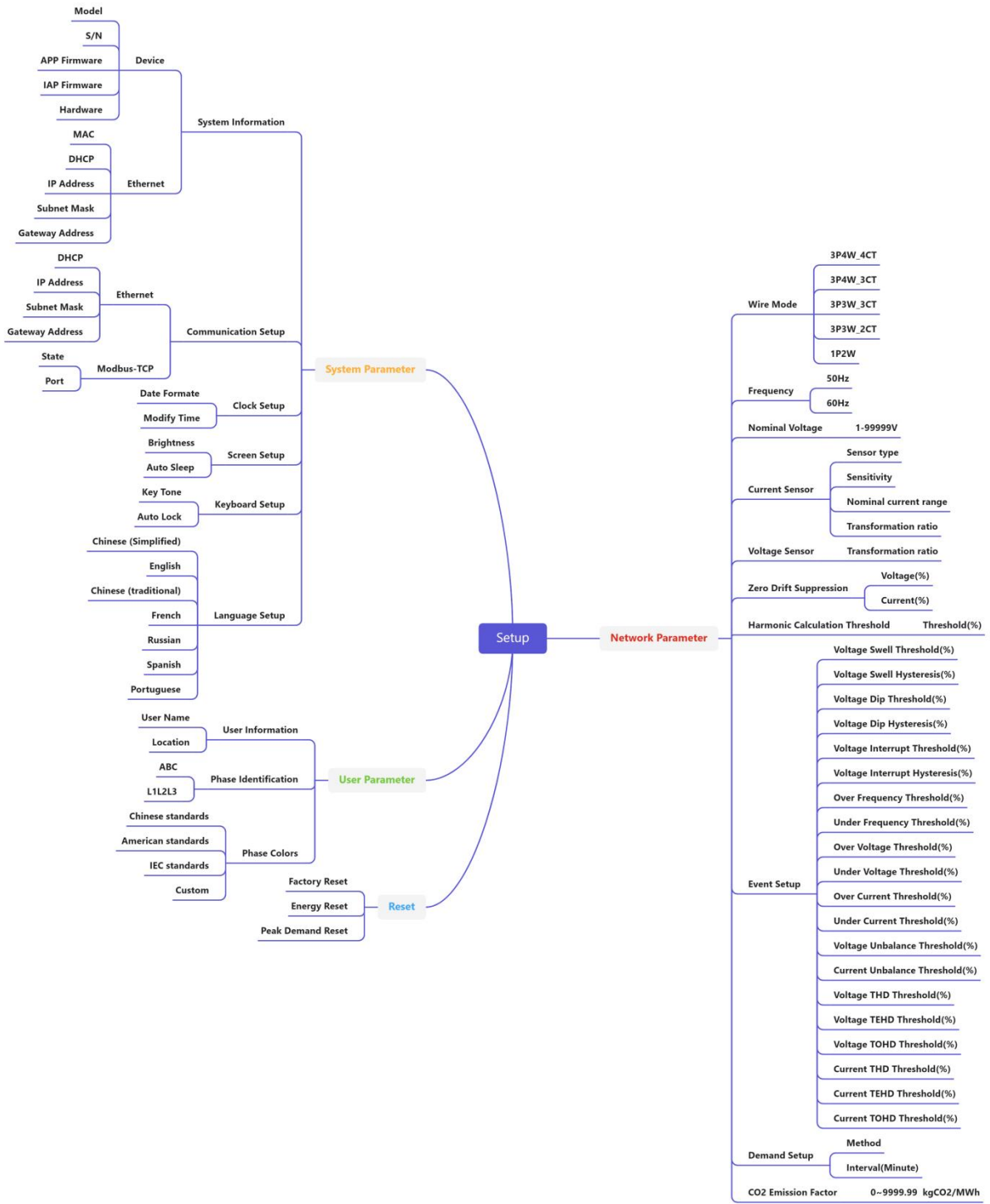

9.2 Measure

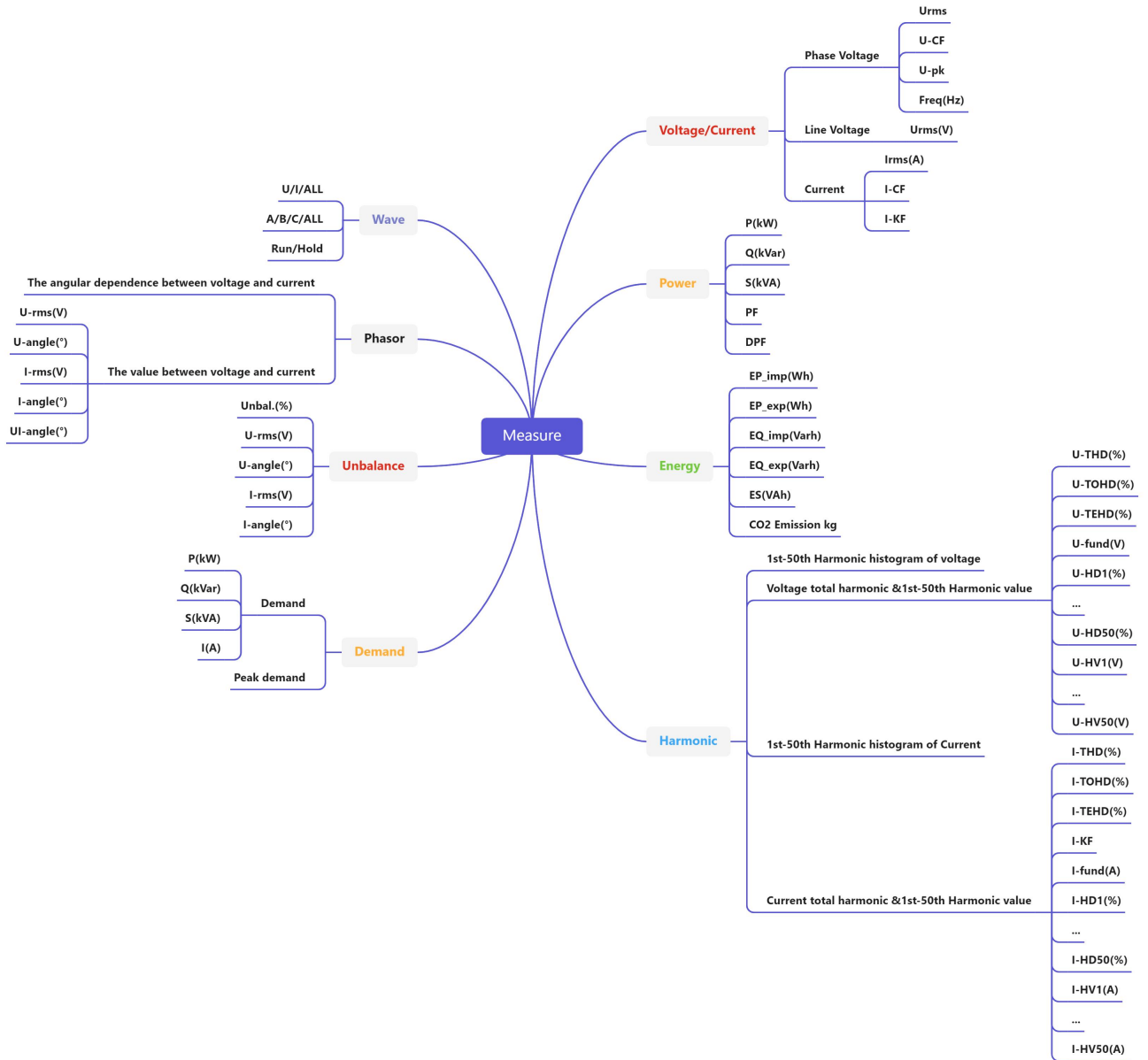

9.3 Record

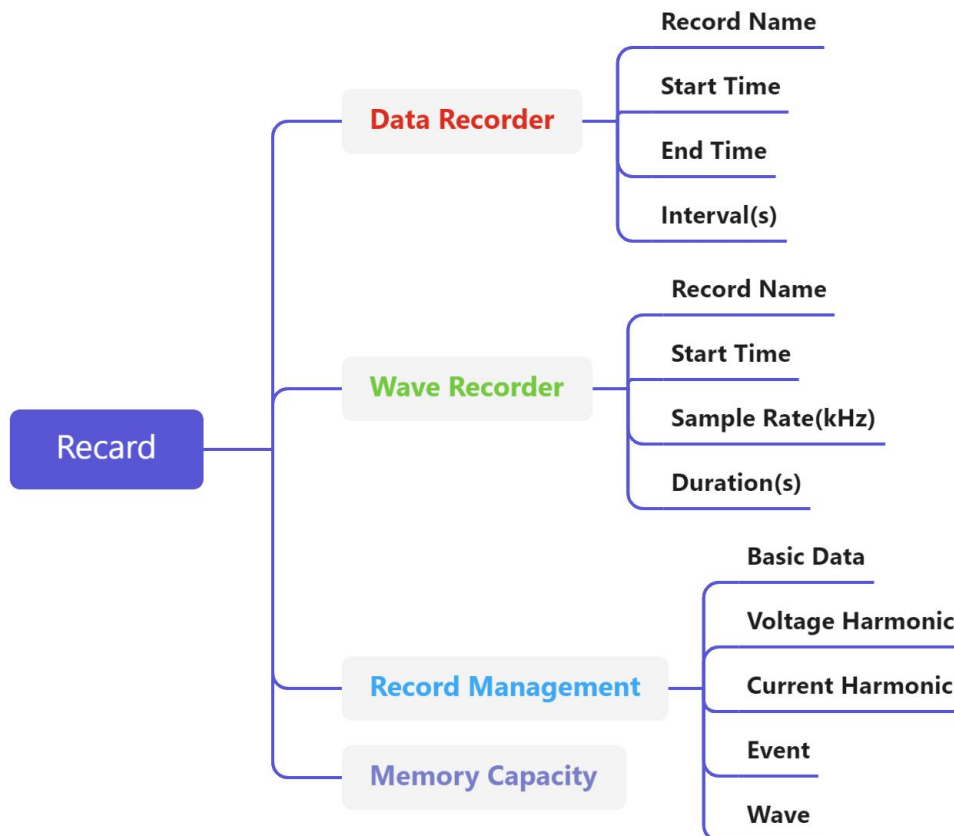



MEATROL[®] ELECTRICAL

ROGOWSKI TECHNOLOGY (SHANGHAI) CO., LTD

TEL: +86 21 64850006

MOB: 18621563567

EAMIL: info@meatrol.cn

WEBSITE: www.rogowski.cn

