



## 230V EMERGENCY LIGHT

### JF091

Please read instructions before commencing installation and retain for future reference.

### SPECIFICATIONS:

- **Fitting:** Plastic body and lens.
- **Lamp type:** T5 fluorescent tube 2x8W max. Lamps and gears excluded unless otherwise specified.
- **Protection against electric shock:** Class II. Double insulated. Does not require earth connection.
- **Ingress Protection:** IP20. Protection against entry of solid objects greater than 12mm.
- **Quality/Corrosive rating:** QC24: Burning period: 12hrs/24hr cycle. Commercial use. Can be used in coastal areas and other corrosive environment.
- **Ballast:** Included.
- **Battery:** Included. Sealed lead acid maintenance free 6V/4AH.
- **Ambient temperature range:** -20°C to +40°C.

### FEATURES:

- Three position switch OFF / 1 TUBE / 2 TUBES.
- Mountable on surface as well as portable with handle.
- Battery back up system which automatically activates during power failure.

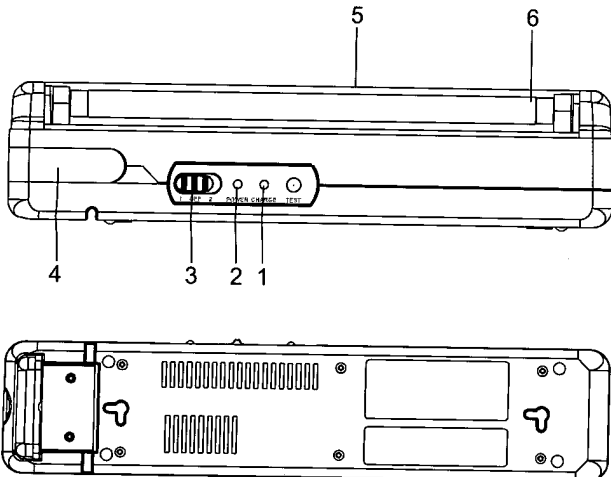

### OPERATING INSTRUCTIONS:

**⚠** Electrical products can cause death, injury, or damage to property. Handle this product with care.

#### To charge the unit:

- For the first time charge battery for 20-24 hours.
- Plug into AC power supply and charge indicator (1) shows that unit is charging.
- Once battery is fully charged the overcharge control will activate.
- When battery indicator (2) goes dim, it shows that power of battery is at a low level, then recharge battery.
- When used for 3-4 hours with emergency function, approx 14-20 hours is needed for recharging.
- The battery will run 1xtube for approx. 6.5 hours or 2xtubes for approx. 3 hours.

#### To use the unit:

- Plug in power cord.
- Slide power source switch to 1 or 2 lamps or off position (3).
- The fluorescent light will active automatically when the power fails.
- To use as portable light ensure battery is fully charged, use as required using handle (4).
- To surface mount, insert masonry plugs into mounting surface. Fix self-tapping screws into masonry plugs leaving sufficient gap to hang fitting. Slide fitting onto screws and lock into position.

#### Tube replacement:

- Remove screws to remove lens (5) and rotate tube (6) in either direction until it's pin appears at top of tube holder slot.
- Pull out tube and replace, pushing new tube all the way in & rotate in either direction.
- Refit lens and secure with screws.

### WARNING:

- **For the first time charge battery for 20-24 hours.**
- To avoid electric shock, do not open the unit for repairing or cleaning unless by a qualified person.
- Don't turn on the unit with tube removed or if improperly installed.
- Don't operate the unit with the lens removed.
- Don't store or operate the unit under extreme temperatures and/or high humidity.
- Use a small cotton swab with cleaning alcohol to clean the unit. Do not use strong or volatile chemicals as it will damage the plastic parts.