

## POLYCRYSTALLINE SILICON MODULE



0260



**10** year  
product  
warranty

**25** year  
power output  
warranty



CNBM

CNBM International Corporation

# 6P-260 6P-265 6P-270 6P-275 6P-280 POLYCRYSTALLINE SILICON MODULE

## Products Characteristics



Widely using of the most popular and mature type of modules for on-grid system.



Leading manufacturing technology in PV industry, strictly controlling the quality of raw materials and the process of producing



100% EL inspection, ensures modules are defects free.



Cells binned by current to improve module performance



Anti reflective glass. Not only to increase the light absorption, but also to make the module has the function of self-cleaning in water environment, effectively reducing the power loss caused by dust.



Outstanding performance in low-light irradiance environments.



Excellent mechanical load resistance: Certified to withstand high wind loads(2400pa) and snow loads(5400pa).



High salt and ammonia resistance



Positive power tolerance: 0~+5w

## Warranty

- 10 year product warranty
- 10 year 90% of Min. rated output power, and 25 year 80% of Min. rated output power warranty

## Comprehensive Certificates

- ISO Certificate
- SGS-TUV Certificate
- CQC Certificate
- IEC61215、IEC61730 Certificate
- CE Certificate

# 6P-260 6P-265 6P-270 6P-275 6P-280



CNBM

CNBM International Corporation

## ▼ Engineering Drawings (Front Side)



## ▼ Engineering Drawings (Back Side)

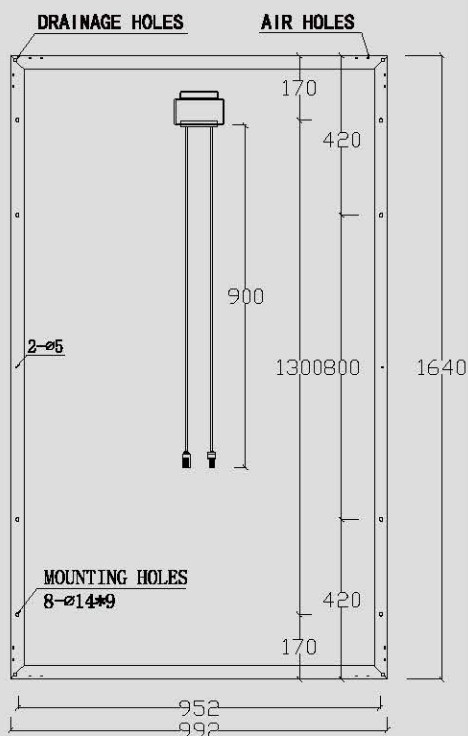

## Raw Materials and Mechanical Parameters

	6P-260	6P-265	6P-270	6P-275	6P-280
Type of Cells(mm)	poly156.75 × 156.75				
NO. of Cells and Connections	6 × 10=60				
Dimensions(mm)(L*W*H)	1640 × 992 × 35/40				
Weight(kg)	17.9/18.2				
Glass	3.2mm Tempered Glass				
Encapsulation	EVA				
Backsheet	Multilayer Composite				
Aluminium-Frame	Silvery/Black Anodized aluminium alloy				
Junction-Box	IP67/IP68				
Cable	4mm <sup>2</sup> ,900mm				
Connector	MC4 and MC4 Compatible				
Package Configuration	30/26 pcs/pallet				

## Performance Parameters

	6P-260	6P-265	6P-270	6P-275	6P-280
Maximum System Voltage	1000V				
Operating Temperature	-45~+80°C				
Maximum Series Fuse	20A				
Maximum Static Load, Front Side (e.x. Snow, Wind)	5400PA				
Maximum Static Load, Back Side (e.x. Wind)	2400PA				
Application Grade	Class A				

## Electrical Parameters (Standard Test Condition)

	6P-260	6P-265	6P-270	6P-275	6P-280
Rated Maximum Power(Mp)	260W	265W	270W	275W	280W
Power Tolerance	0~+5W				
Cell Efficiency	17.7%	18.0%	18.4%	18.7%	19.0%
Open Circuit Voltage(Voc)	37.9V	38.1V	38.3V	38.6V	38.8V
Maximum Power Voltage(Vmp)	30.7V	30.9V	31.1V	31.3V	31.5V
Short Circuit Current(Isc)	8.98A	9.09A	9.20A	9.31A	9.42A
Maximum Power Current(Imp)	8.47A	8.58A	8.68A	8.79A	8.89A
Temperature Coefficient of Isc	+0.06%				
Temperature Coefficient of Voc	-0.33%				
Temperature Coefficient of Pmp	-0.45%				
Standard Test Condition	Irradiance:1000W/M2, Cell Temperature:25°C, Spectrum AM:1.5				

The Electrical Parameters of the module are the average theory figure under the standard test condition, each one exists difference. Can not be treated as the basis of module delivery.

## POLYCRYSTALLINE SILICON MODULE



0260



**10** year  
product  
warranty

**25** year  
power output  
warranty



CNBM

CNBM International Corporation

## 6P-310 6P-315 6P-320 6P-325 6P-330 6P-335 POLYCRYSTALLINE SILICON MODULE

### Products Characteristics



Widely using of the most popular and mature type of modules for on-grid system.



Leading manufacturing technology in PV industry, strictly controlling the quality of raw materials and the process of producing



100% EL inspection, ensures modules are defects free.



Cells binned by current to improve module performance



Anti reflective glass. Not only to increase the light absorption, but also to make the module has the function of self-cleaning in water environment, effectively reducing the power loss caused by dust.



Outstanding performance in low-light irradiance environments.



Excellent mechanical load resistance: Certified to withstand high wind loads(2400pa) and snow loads(5400pa).



High salt and ammonia resistance



Positive power tolerance: 0~+5w

### Warranty

- 10 year product warranty
- 10 year 90% of Min. rated output power, and 25 year 80% of Min. rated output power warranty

### Comprehensive Certificates

- ISO Certificate
- SGS-TUV Certificate
- CQC Certificate
- IEC61215、IEC61730 Certificate
- CE Certificate

Specifications subject to technology and test conditions,  
GSUN Power reserves the right of final interpretation





▼ Engineering Drawings (Front Side)



▼ Engineering Drawings (Back Side)

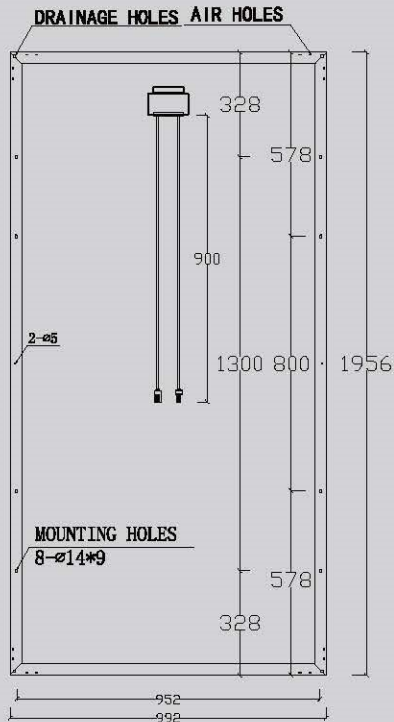

## Raw Materials and Mechanical Parameters

	6P-310	6P-315	6P-320	6P-325	6P-330	6P-335
Type of Cells(mm)	poly156.75 × 156.75					
NO. of Cells and Connections	6 × 12=72					
Dimensions(mm)(L*W*H)	1956 × 992 × 40					
Weight(kg)	22.8					
Glass	3.2mm Tempered Glass					
Encapsulation	EVA					
Backsheet	Multilayer Composite					
Aluminium-Frame	Silvery/Black Anodized aluminium alloy					
Junction-Box	IP67/IP68					
Cable	4mm <sup>2</sup> ,900mm					
Connector	MC4 and MC4 Compatible					
Package Configuration	26pcs/pallet					

## Performance Parameters

	6P-310	6P-315	6P-320	6P-325	6P-330	6P-335
Maximum System Voltage	1000V					
Operating Temperature	-45~+80℃					
Maximum Series Fuse	20A					
Maximum Static Load, Front Side (e.x. Snow, Wind)	5400PA					
Maximum Static Load, Back Side(e.x. Wind)	2400PA					
Application Grade	Class A					

## Electrical Parameters (Standard Test Condition)

	6P-310	6P-315	6P-320	6P-325	6P-330	6P-335
Rated Maximum Power(Mp)	310W	315W	320W	325W	330W	335W
Power Tolerance	0- + 5W					
Cell Efficiency	17.6%	17.9%	18.1%	18.4%	18.7%	19.0%
Open Circuit Voltage(Voc)	46.0V	46.2V	46.5V	46.7V	47.0V	47.2V
Maximum Power Voltage(Vmp)	36.7V	36.9V	37.1V	37.3V	37.5V	37.7V
Short Circuit Current(Isc)	8.95A	9.05A	9.21A	9.33A	9.38A	9.43A
Maximum Power Current(Imp)	8.45A	8.54A	8.72A	8.84A	8.89A	8.95A
Temperature Coefficient of Isc	+0.06%					
Temperature Coefficient of Voc	-0.33%					
Temperature Coefficient of Pmp	-0.45%					
Standard Test Condition	Irradiance:1000W/M2, Cell Temperature:25℃, Spectrum AM:1.5					

The Electrical Parameters of the module are the average theory figure under the standard test condition, each one exists difference. Can not be treated as the basis of module delivery.