



TBA120S IF Amplifier and Detector

General Description

The TBA120S is a monolithic integrated circuit specifically designed for audio detection in TV and FM radio receivers. It incorporates an 8-stage limiting IF amplifier and balanced detector plus a DC operated volume control.

The TBA120S is supplied in four groups depending on the resistance required between pin 5 and ground to attenuate the audio output by 30 dB. The group number as defined below is marked on the package.

Group	II	III	IV	V	
R5-GND	1.9-2.2	2.1-2.5	2.4-2.9	2.8-3.3	k Ω

Pins 3 and 4 are connected to the collector and base of a transistor which may be used as an AF-preamplifier or as a switch.

At pin 12 a zener-diode is accessible which can be used to stabilize the supply voltage of this integrated circuit or the voltage of other circuit elements in the set.

Features

- Electronic attenuator: replaces conventional AC volume control
- Volume reduction range 85 dB typ
- Sensitivity: 3 dB limiting voltage 30 μ V typ
- Excellent AM rejection 68 dB typ at 10 mV
- Audio output voltage 1V typ
- Wide supply voltage range (6V-18V)
- Internal zener diode regulator
- Very low external component requirement
- Simple detector alignment: one coil

Connection Diagram

Dual-In-Line Package

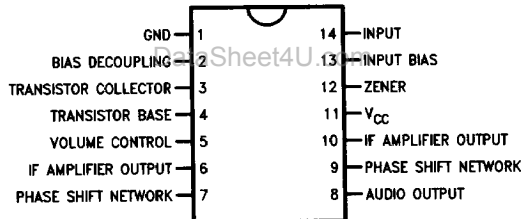

TL/H/9319-1

Top View

Order Number TBA120S II, TBA120S III, TBA120S IV or TBA120S V
See NS Package Number N14A

Absolute Maximum Ratings

If Military/Aerospace specified devices are required, contact the National Semiconductor Sales Office/Distributors for availability and specifications.

Supply Voltage, V11	18V
Volume Control Voltage, V5	4V
Zener Current, I ₁₂	20 mA

Transistor Collector Current, I ₃	5 mA
Transistor Base Current, I ₄	2 mA
Bias Resistance (Max), R13-14	1 kΩ
Operating Temperature Range	-15°C to +70°C
Storage Temperature Range	-65°C to +150°C

Electrical Characteristics (V_{CC} = 12V, T_A = 25°C)

Symbol	Parameter	Conditions	Min	Typ	Max	Units
I _{CC}	Supply Current	R5 = ∞	10	14	18	mA
		R5 = 0	11		20	
G _V	IF Voltage Gain	f = 5.5 MHz		68		dB
V _O	IF Output Voltage, Each Output at Limiting		170	250		mVp-p
V _{af}	AF Output Voltage	f = 5.5 MHz, Δf = ±50 kHz, f _{MOD} = 1 kHz, V _I = 10 mV, Q = 45	0.7	1.0		V
	Distortion (5.5 MHz)	f = 5.5 MHz, Δf = 25 kHz, f _{MOD} = 1 kHz, V _I = 10 mV, Q = 45		1.5		%
	Distortion (10.7 MHz)	f = 10.7 MHz, Δf = ±50 kHz, f _{MOD} = 1 kHz, V _I = 10 mV, Q = 20		0.2		
V _{LIM}	Input Voltage Before Limiting	f = 5.5 MHz, Δf = ±50 kHz, f _{MOD} = 1 kHz, Q = 45		30	60	μV
Z _I	Input Impedance	f = 5.5 MHz	15/6	40/4.5		kΩ/pF
R _O	Output Resistance		1.9	2.6	3.3	kΩ
$\frac{V_{af \max}}{V_{af \min}}$	Volume Control Range		70	85		dB
V _B	DC Component of the Output Signal	V _I = 0	6.2	7.3	8.4	V
a _{AM}	AM Rejection	f = 5.5 MHz, Δf = ±50 kHz, f _{MOD} = 1 kHz, V _I = 500 μV, m = 30%	50	60		dB
a _{AM}	AM Rejection	f = 5.5 MHz, Δf = ±50 kHz, f _{MOD} = 1 kHz, V _I = 10 mV, m = 30%		68		dB
R5	Potentiometer Resistance	1 dB Attenuation		3.7	4.7	kΩ
V5	Voltage	1 dB Attenuation		2.2	2.5	V
R5	Potentiometer Resistance	70 dB Attenuation	1.0	1.4		kΩ
V5	Voltage	70 dB Attenuation		1.2		V
	Noise Voltage at Output	V _I = 10 mV		30		μV
V12	Zener Voltage	I ₁₂ = 5 mA	11.2	12	13.4	V
R _Z	Zener Slope Resistance			30	50	Ω
V _{cbo}	Breakdown Voltage		45	65		V
V _{ceo}	Breakdown Voltage	I ₃ = 500 μA	18	24		V
h _{fe}	Current Gain	I ₃ = 1 mA	50	100	500	

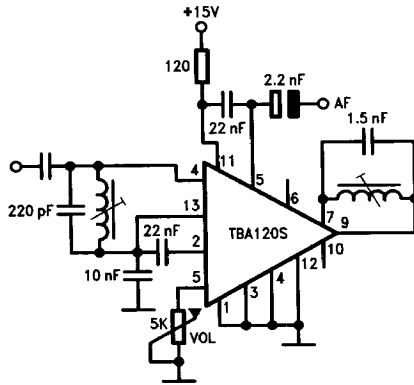
Typical Application (5.5 MHz)

TL/H/9319-2

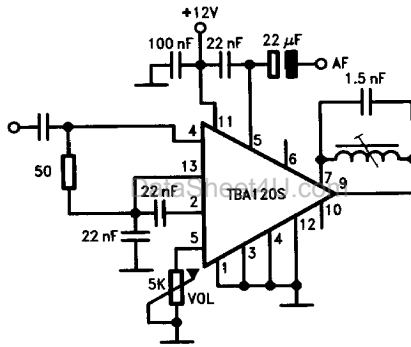
Test Circuit (5.5 MHz)

TL/H/9319-3

Schematic Diagram

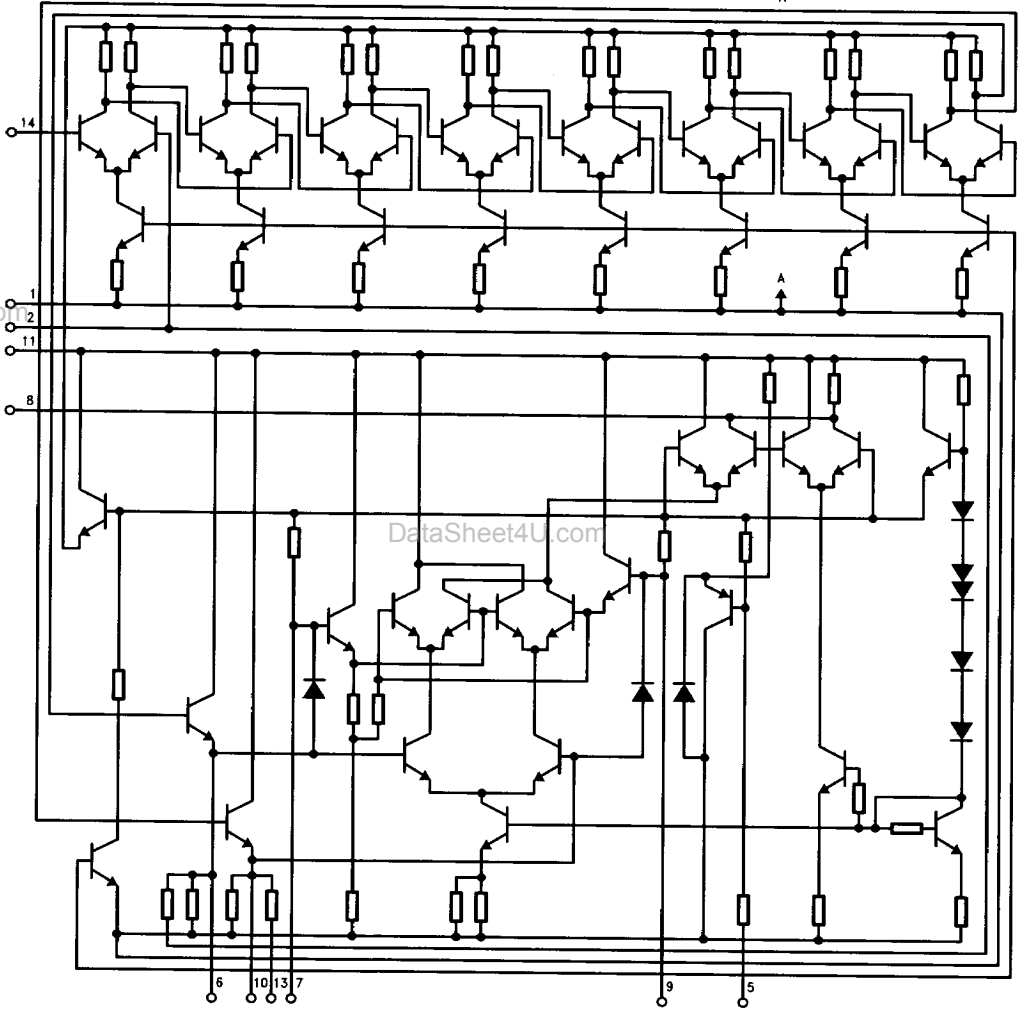
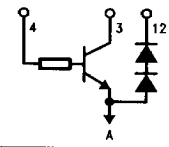

TL/H/9319-4