

**FM STEREO DECODER**

- REQUIRES NO INDUCTORS
- LOW EXTERNAL PART COUNT
- ONLY OSCILLATOR FREQUENCY ADJUSTMENT NECESSARY
- INTEGRAL STEREO/MONAUROAL SWITCH WITH HIGH LAMP DRIVING CAPABILITY
- WIDE SUPPLY RANGE : 3V TO 14V
- EXCELLENT CHANNEL SEPARATION MAINTAINED OVER ENTIRE AUDIO FREQUENCY RANGE
- LOW DISTORSION : TYPICALLY 0.3% AT 150mV<sub>RMS</sub> COMPOSITE INPUT SIGNAL
- EXCELLENT SCA REJECTION (76dB Typ.)

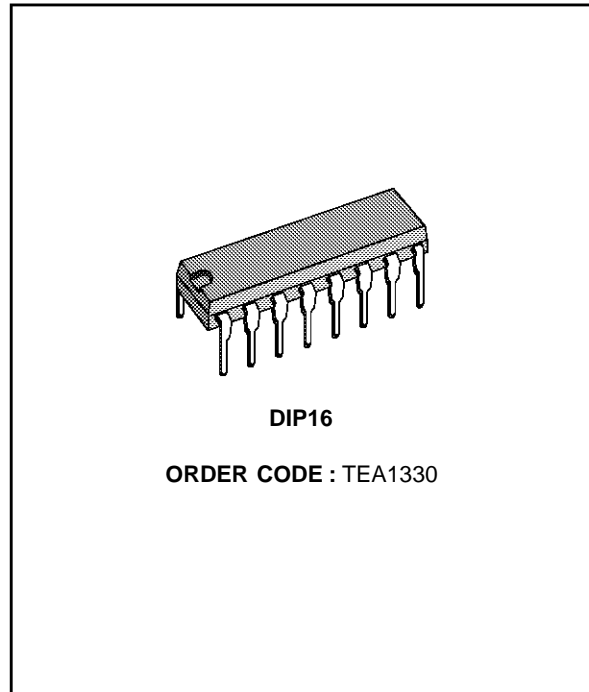

**DESCRIPTION**

The TEA1330 is a monolithic decoder circuit for FM stereo transmissions. Packaged in a 16-pin DIP, it functions with very few external components and requires no inductors.

**PIN CONNECTION**

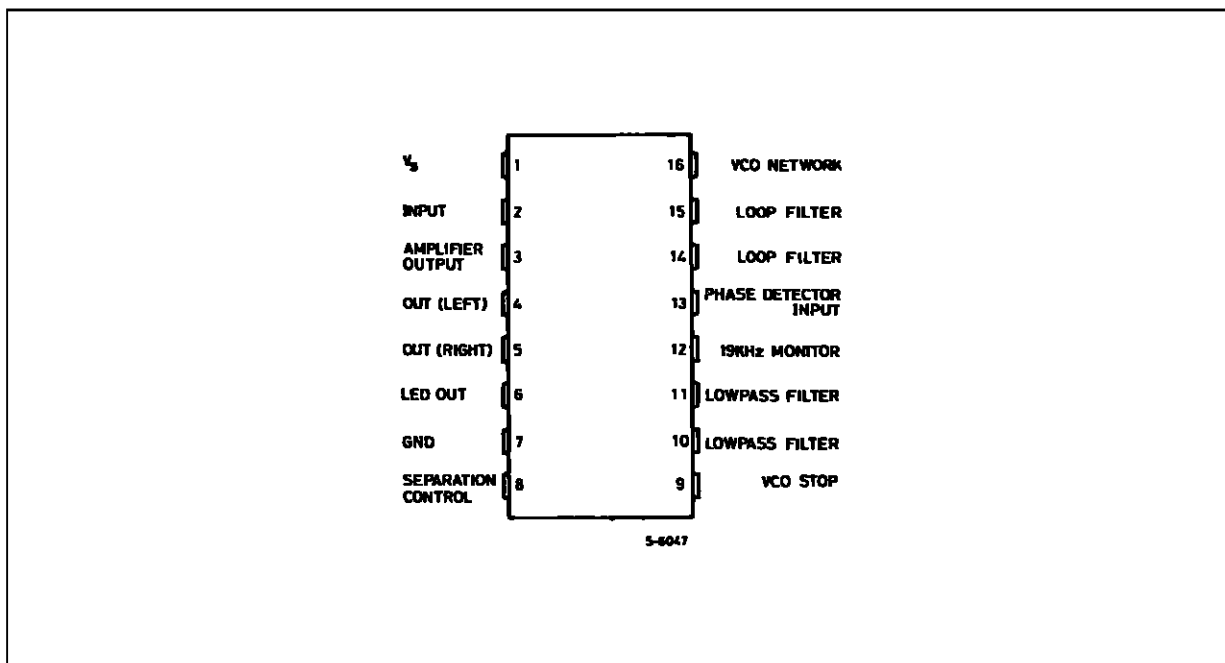

BLOCK DIAGRAM

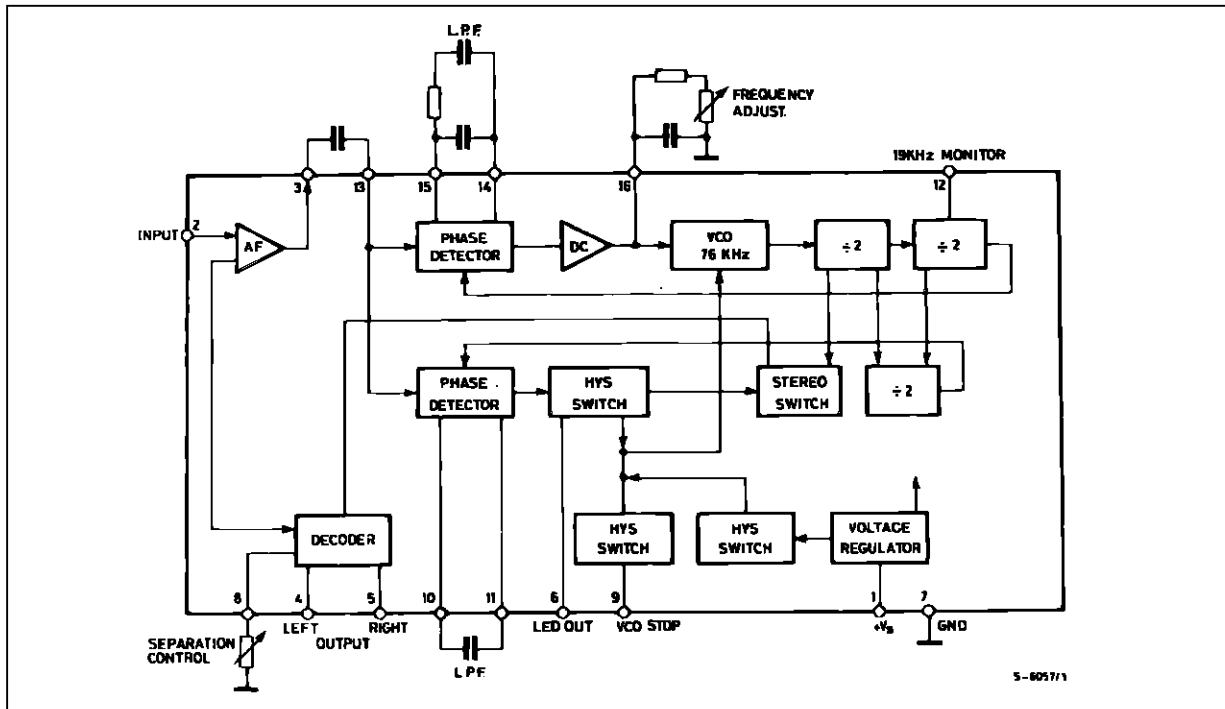

ABSOLUTE MAXIMUM RATINGS

Symbol	Parameter	Value	Unit
V <sub>S</sub>	Supply Voltage	16	V
I <sub>L</sub>	Lamp Current	75	mA
P <sub>tot</sub>	Power Dissipation at T <sub>amb</sub> = 70°C	800	mW
T <sub>oper</sub>	Operating Temperature	- 25, + 75	°C
T <sub>stg</sub>	Storage Temperature	- 55, + 150	°C

THERMAL DATA

Symbol	Parameter	Value	Unit
R <sub>th (j-a)</sub>	Junction-ambient Thermal Resistance	Max. 100	°C/W

ELECTRICAL CHARACTERISTICS (refer to the test circuit, T<sub>amb</sub> = 25°C, V<sub>S</sub> = 6V, V<sub>I</sub> = 300mV<sub>RMS</sub> (L + R = 90%, pilot 10%), f<sub>m</sub> = 1kHz, unless otherwise specified)

Symbol	Parameter	Test Conditions	Min.	Typ.	Max.	Unit
V <sub>S</sub>	Supply Voltage Range		3		14	V
I <sub>D</sub>	Current Drain	Lamp "OFF"		18		mA
V <sub>I</sub>	Max. Standard Composite Input Signal	d = 1%	300			mV <sub>RMS</sub>
V <sub>I</sub>	Max. Mono Input Signal	d = 1%	300			mV <sub>RMS</sub>
R <sub>I</sub>	Input Resistance			40		kΩ
Sep	Stereo Channel Separation	R2 = Variable (see note 1) R2 = 270Ω	35 25	50 40		dB dB
V <sub>O</sub>	Audio Output Voltage			265		mV
CB	Mono Channel Balance	Pilot Tone "OFF"	- 2	0	+ 2	dB
d	Total Harmonic Distortion	V <sub>IN</sub> = 150mV <sub>RMS</sub>		0.3		%
UR	Ultrasonic Frequency Rejection	f = 19kHz f = 38kHz		32 48		dB dB

**ELECTRICAL CHARACTERISTICS** (continued)

Symbol	Parameter	Test Conditions	Min.	Typ.	Max.	Unit
SCA-R	SCA Rejection (see note 2)	f = 67kHz		76		dB
S/N	Signal to Noise Ratio			80		dB
V <sub>th</sub>	Muting Threshold Voltage (Pin 9)	ON (VCO stop) OFF		1 0.8		V V
L <sub>ON</sub>	Pilot Input Level for Lamp ON	f = 19kHz	4	6	9	mV
Hys	Pilot Input Level Hysteresis for Lamp Turn ON-OFF	f = 19kHz		3		dB
CR	Capture Range			± 7		%

Notes : 1. R2 has to be adjusted for best figure of channel separation.  
2. SCA = AUX. SUB. CARRIER.

**Figure 1 : Test Circuit**

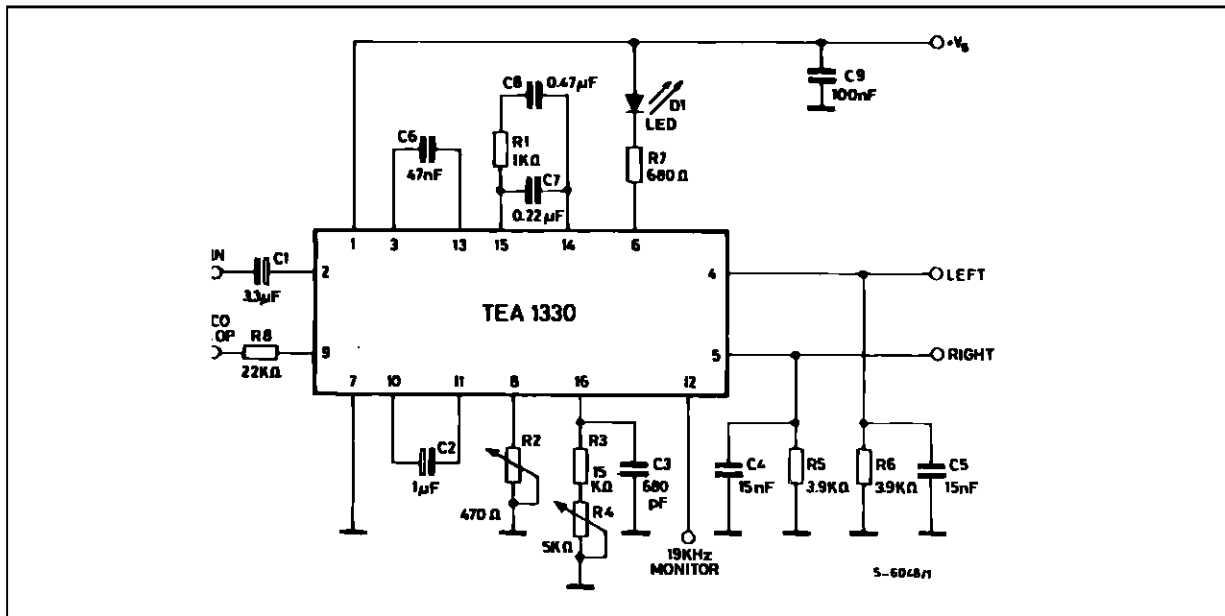

**TYPICAL DC VOLTAGES**

Pins	1	2	3	4	5	6	7	8	9	10	11	12	13	14	15	16
(V)	6	1.9	1.3	3	3		0	0.18		1.4	1.4	1.2	1.4	1.4	1.4	2.2

**Figure 2 : P.C. Board and Components layout of the test Circuit of Figure 1 (1:1 scale)**

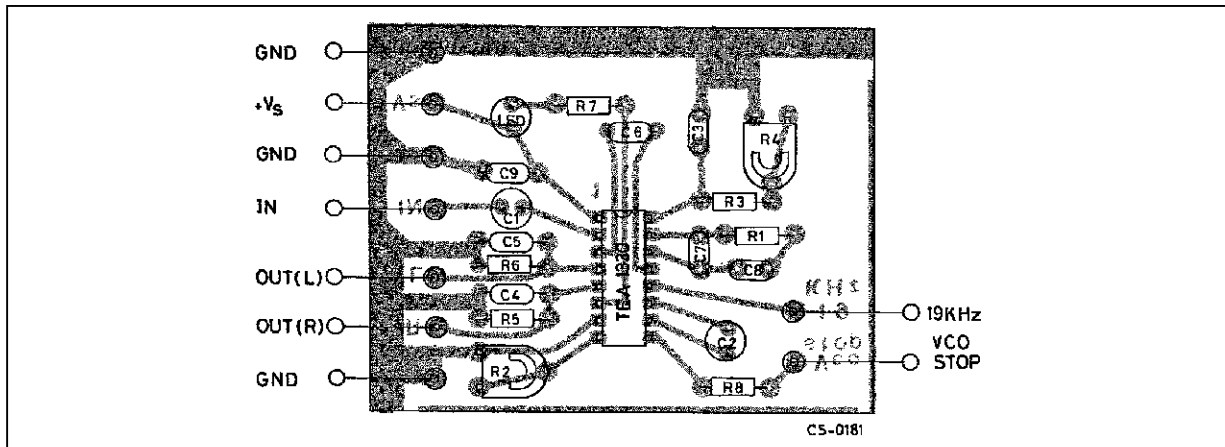

**Figure 3 :** Channel Separation versus Modulation Frequency

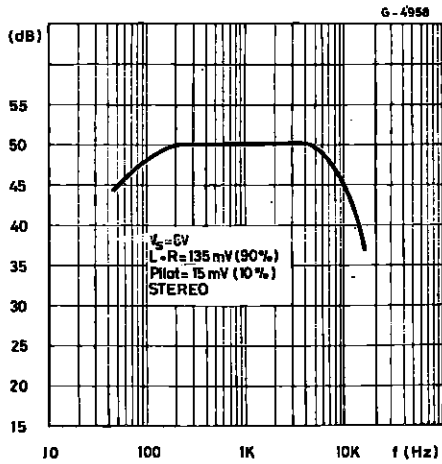

**Figure 4 :** Distorsion versus Modulation Frequency

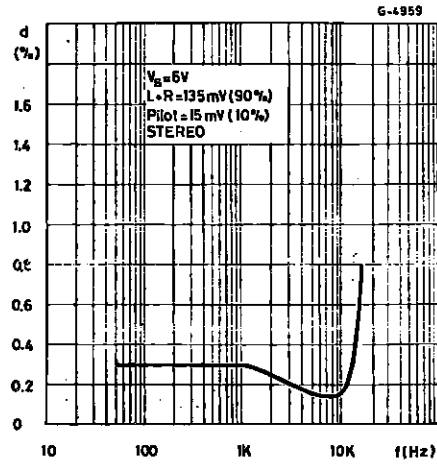

**Figure 5 :** Channel Separation versus Input Level

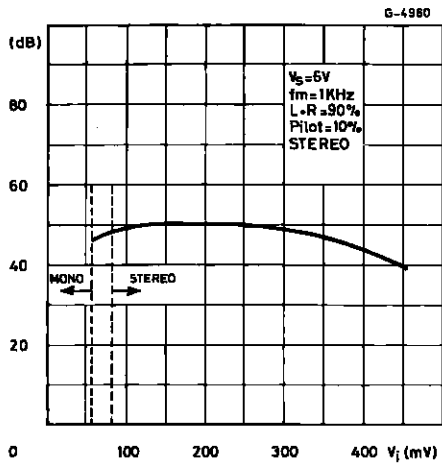

**Figure 6 :** Distorsion versus Input Level

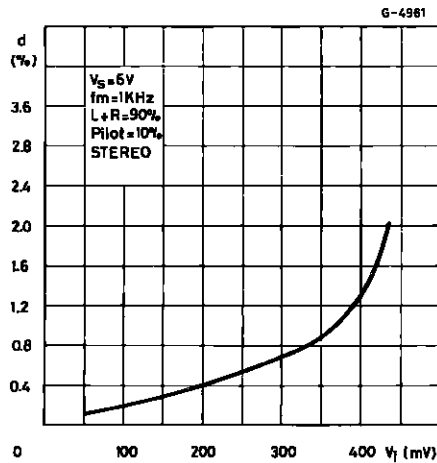

**Figure 7 :** Channel Separation versus Supply Voltage

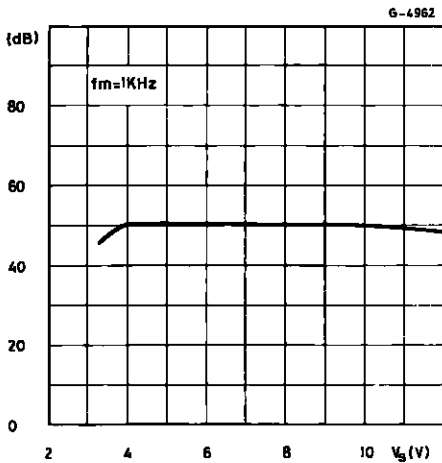

**Figure 8 :** Distorsion versus Supply Voltage

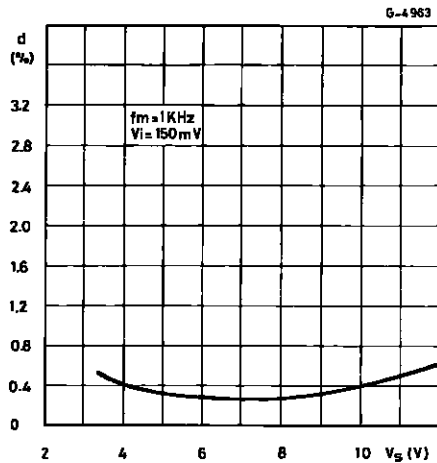

## APPLICATION SUGGESTION (see Test Circuit of Figure 1)

Component	Recommended Value	Purpose	Smaller than Recommended Value	Larger than Recommended Value
C1	3.3mF	Input Coupling	Poor Low Frequency Response and Separation	
C2	1 $\mu$ F	LPF for Stereo Switch Level Detector	Shorter Time to Switch Mono to Stereo	Longer Time to Switch Mono to Stereo
C3 (note 1) R3 R4	680pF 15k $\Omega$ 5k $\Omega$	Set VCO Free Running Frequency		Narrower Capture Range
C4 R5 (note 2)	15nF 3.9k $\Omega$	Load and Deemphasis Right Channel	Low Output Voltage	Higher Distorsion for Low $V_s$
C5 R6 (note 2)	15nF 3.9k $\Omega$	Load and Deemphasis Left Channel	Low Output Voltage	Higher Distorsion for Low $V_s$
C6	47nF	Input PLL Coupling	Poor Low Frequency Response and Separation	
C7 C8 R1	220nF 470nF 1k $\Omega$	Loop Filter	High Stereo Distorsion	Narrower Capture Range
D1		Stereo Indicator		
R7		Sets Lamp Current	Excess IC Dissipation	Dim Lamp
RE (note 3)	270 $\Omega$	Channel Separation		

- Notes :
1. Polyester  $\pm$  5%
  2. Deemphasis = 50 $\mu$ s
  3. Separation can be improved by trimmer adjustment (470 $\Omega$ )

Figure 9 : Application Circuit for Portable Stereo Radio Receivers

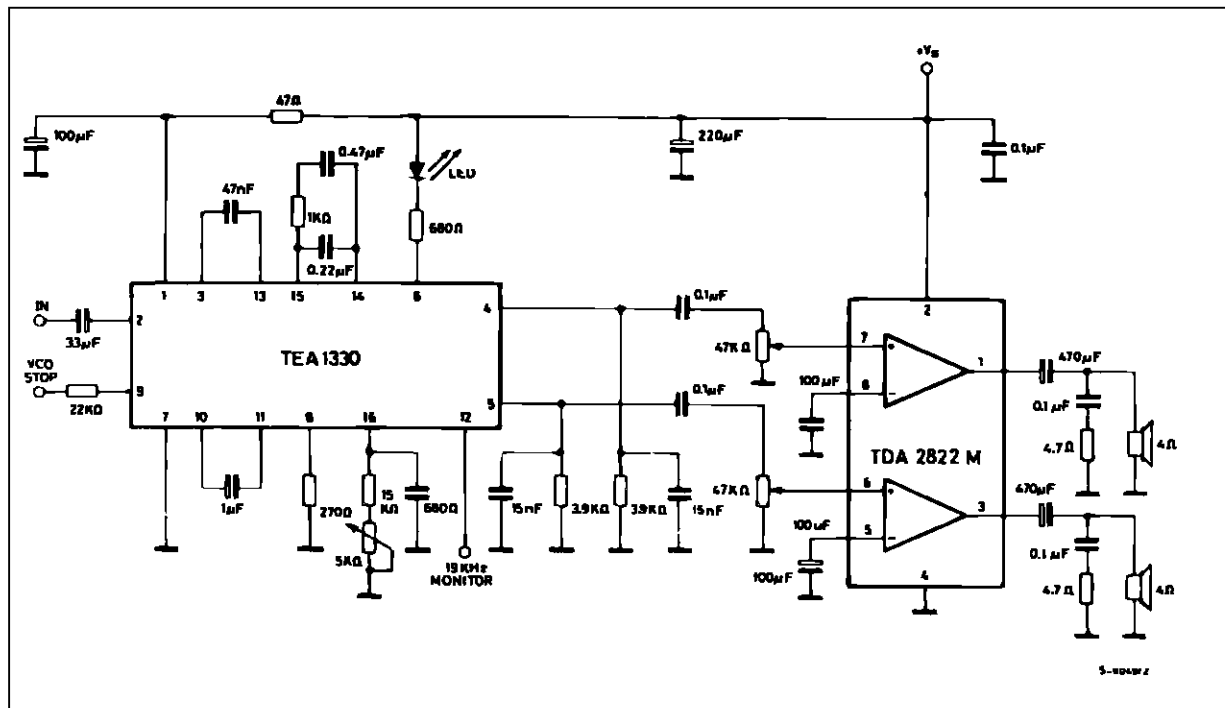

DIP16 PACKAGE MECHANICAL DATA

DIM.	mm			inch		
	MIN.	TYP.	MAX.	MIN.	TYP.	MAX.
a1	0.51			0.020		
B	0.77		1.65	0.030		0.065
b		0.5			0.020	
b1		0.25			0.010	
D			20			0.787
E		8.5			0.335	
e		2.54			0.100	
e3		17.78			0.700	
F			7.1			0.280
I			5.1			0.201
L		3.3			0.130	
Z			1.27			0.050

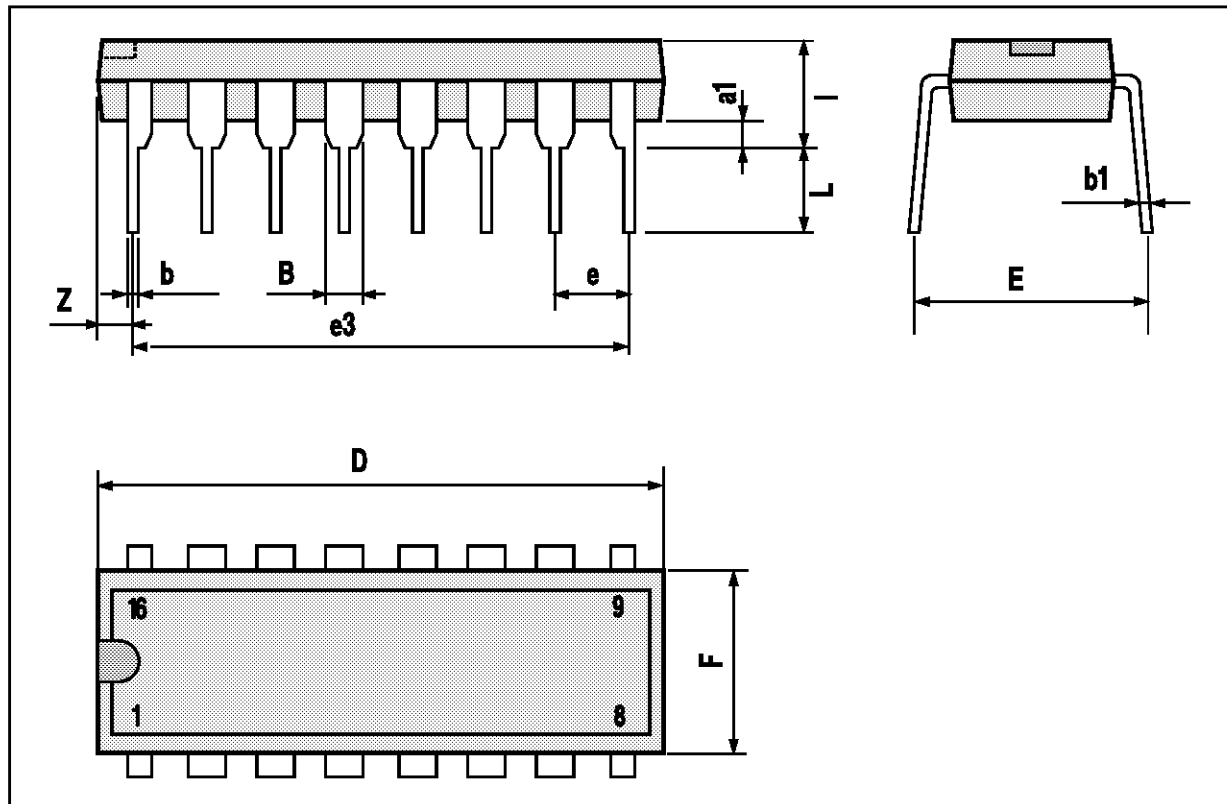

Information furnished is believed to be accurate and reliable. However, SGS-THOMSON Microelectronics assumes no responsibility for the consequences of use of such information nor for any infringement of patents or other rights of third parties which may result from its use. No license is granted by implication or otherwise under any patent or patent rights of SGS-THOMSON Microelectronics. Specifications mentioned in this publication are subject to change without notice. This publication supersedes and replaces all information previously supplied. SGS-THOMSON Microelectronics products are not authorized for use as critical components in life support devices or systems without express written approval of SGS-THOMSON Microelectronics.

© 1994 SGS-THOMSON Microelectronics - All Rights Reserved

SGS-THOMSON Microelectronics GROUP OF COMPANIES

Australia - Brazil - France - Germany - Hong Kong - Italy - Japan - Korea - Malaysia - Malta - Morocco - The Netherlands - Singapore - Spain - Sweden - Switzerland - Taiwan - Thailand - United Kingdom - U.S.A.