

Gboard Pro

-GSM/GPRS/Wireless dev platform based on Arduino

Overview

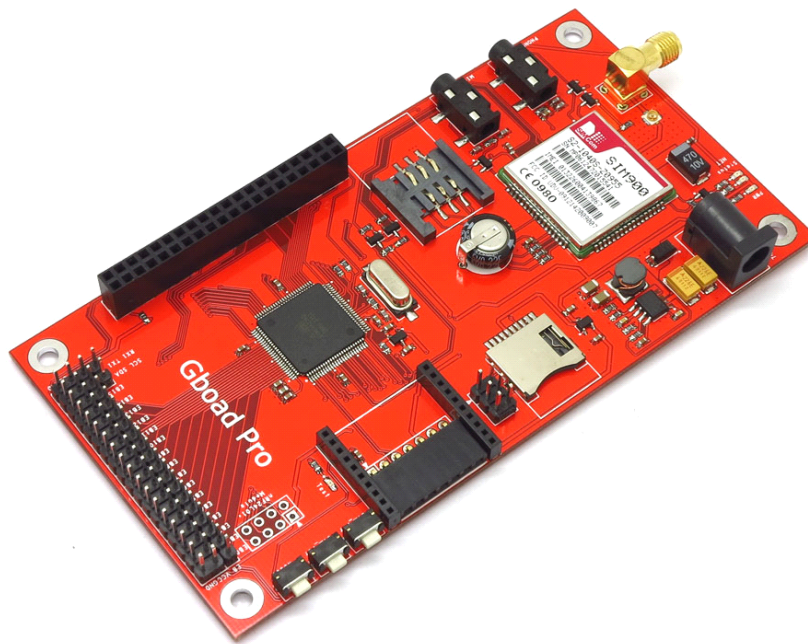

Gboard Pro is a unique Arduino mainboard with SIM900 GSM / GPRS module, XBee socket, nRF24L01 + module interface, micro SD card interface, ITDB02 parallel LCD module interface, electronic brick interface and ATmega2560 chips, which can achieve wireless control via XBee, nRF24L01 + or GSM / GPRS with functions covering from smart home to remote control of robots to meet various needs of different projects.

Specifications

PCB size	131.0mm X 68.8mm X 1.6mm
Supply voltage	7~23V DC
Operating voltage	3.3V DC
Microprocessor	ATmega2560
Indicators	PWR , NET , Status , Test
Communication interfaces	XBee , nRF24L01+ , UART , IIC , ITDB02 LCD , micro SD

Electrical characteristics

Parameter	Min.	Typical	Max.	Unit
Supply voltage	7	-	23	VDC
Input high voltage VH	3	3.3	3.6	V
Input low voltage	-0.3	0	0.5	V
Average Current consumption	-	100	500	mA
Peak Current consumption	-	-	2	A

Hardware

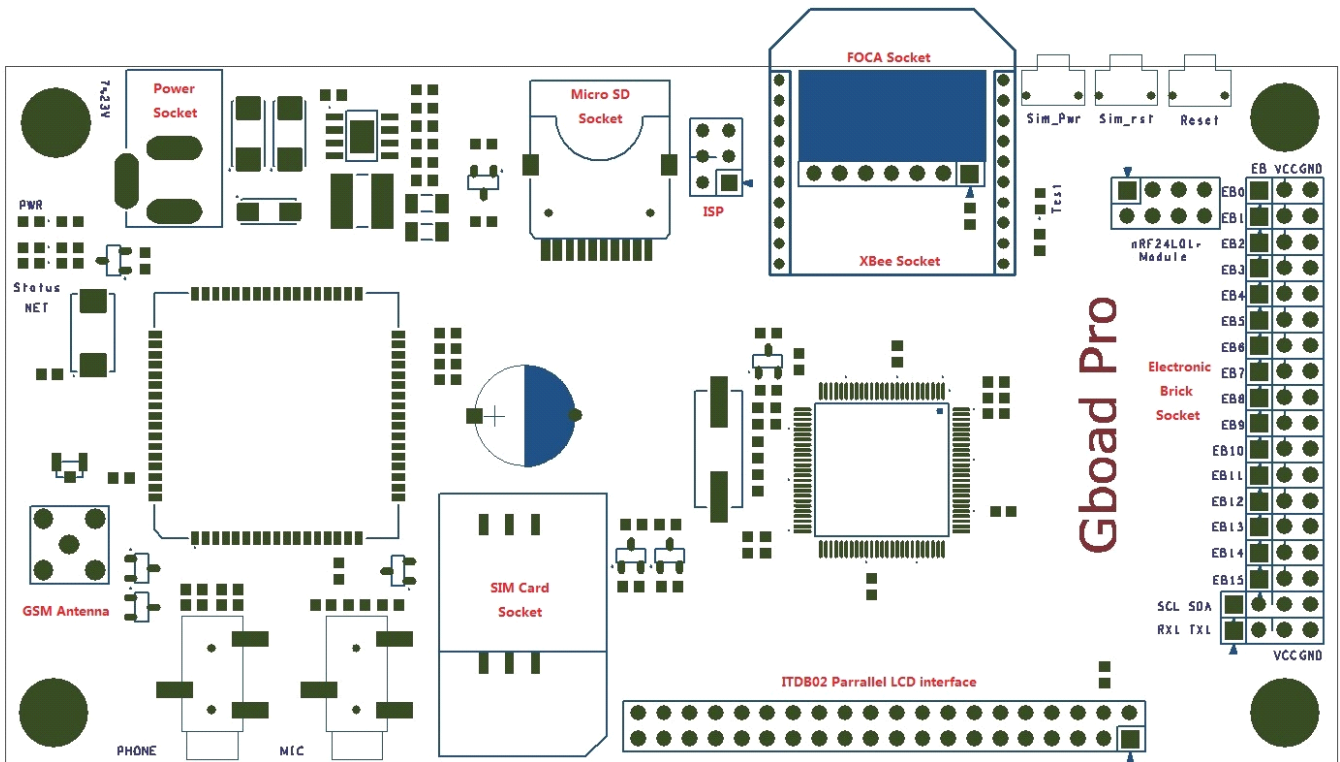

Pin map

ITDB02 Parallel LCD Module Interface

Index of Interface	Name of Interface	Index of Arduino	Pin of Atmega2560
1	GND	-	-

2	DB0	D37	PC0
3	5V	-	-
4	DB1	D36	PC1
5	NC	-	-
6	DB2	D35	PC2
7	LCD_RS	D38	PD7
8	DB3	D34	PC3
9	LCD_WR	D39	PG2
10	DB4	D33	PC4
11	LCD_RD	3V3	3V3
12	DB5	D32	PC5
13	DB8	D22	PA0
14	DB6	D31	PC6
15	DB9	D23	PA1
16	DB7	D30	PC7
17	DB10	D24	PA2
18	Touch_CLK	D6	PH3
19	DB11	D25	PA3
20	Touch_CS	D5	PE3
21	DB12	D26	PA4
22	Touch_DIN	D48	PL1
23	DB13	D27	PA5
24	Touch_BUSY	-	-
25	DB14	D28	PA6
26	Touch_DOUT	D3	PE5
27	DB15	D29	PA7
28	Touch_IRQ	D2	PE4
29	LCD_CS	D40	PG1
30	SD_MISO	D50	PB3
31	NC	-	-
32	SD_SCK	D52	PB1
33	LCD_RST	D41	PG0
34	SD_MOSI	D51	PB2
35	NC	-	-
36	SD_CS	D53	PB0
37	LED+	3V3	3V3
38	NC	-	-
39	LED-	GND	GND
40	NC	-	-

Electronic Bricks Interface

Index of Interface	Name of Interface	Index of Arduino	Pin of Atmega2560
1	EBO	A0	PF0
2	EB1	A1	PF1

3	EB2	A2	PF2
4	EB3	A3	PF3
5	EB4	A4	PF4
6	EB5	A5	PF5
7	EB6	A6	PF6
8	EB7	A7	PF7
9	EB8	A8	PK0
10	EB9	A9	PK1
11	EB10	A10	PK2
12	EB11	A11	PK3
13	EB12	A12	PK4
14	EB13	A13	PK5
15	EB14	A14	PK6
16	EB15	A15	PK7
17	SCL	D21	PD0
18	SDA	D20	PD1
19	RX1	D19	PD2
20	TX1	D18	PD3

nRF24L01+ Module Interface

Index of Interface	Name of Interface	Index of Arduino	Pin of Atmega2560
1	GND	-	-
2	3V3	-	-
3	CE	D12	PB6
4	CS	D11	PB5
5	SCK	D9	PH6
6	MOSI	D8	PH5
7	MISO	D7	PH4
8	IRQ	-	PE7

Micro SD Socket

Index of Interface	Name of Interface	Index of Arduino	Pin of Atmega2560
1	SD_CS	D4	PG5
2	SD_MOSI	D51	PB2
3	3V3	-	-
4	SD_SCK	D52	PB1
5	GND	-	-
6	SD_MISO	D50	PB3

XBee Interface

Index of Interface	Name of Interface	Index of Arduino	Pin of Atmega2560
1	XBee_DOUT	D15(RX3)	PJ0

2	XBee_DIN	D14(TX3)	PJ1
---	----------	----------	-----

SIM900 Communication Interface

Index of Interface	Name of Interface	Index of Arduino	Pin of Atmega2560
1	SIM900_TXD	D17(RX2)	PH0
2	SIM900_RXD	D16(TX2)	PH1
3	SIM900_RST	D47	PL2
4	SIM900_PWR	D46	PL3

Indicators

1. PWR
Power indicator : Normally ON indicates normal power supply to Gboard Pro.
2. Status
Status indicator : Normally ON indicates SIM900 already powered on.
3. NET
Network indicator : OFF indicates SIM900 does not work; ON for 64ms / OFF for 800ms indicates SIM900 did not find the network; ON for 64ms / OFF for 3000ms indicates SIM900 registered on the network; ON for 64ms / OFF for 300ms indicates GPRS communication.

Buttons

1. Reset
ATmega2560 reset button : press the button to reset ATmega2560.
2. Sim_rst
SIM900 reset button : press the button to reset SIM900.
3. sim_pwr
SIM900 power button : if SIM900 is powered off, it will be powered on by keeping pressing the button (for more than 500ms); if SIM900 is powered on, it will be powered off by keeping pressing the button (for more than 500ms).

SIM900 power supply and reset connection

In Gboard Pro , power and reset buttons of SIM900 can be operated via software I/O pins, and the connection of pins is shown as below:

Arduino pin	SIM900 pin	Enable
D46	PWR	High level Active
D47	RESET	High level Active

Revision record

Version	Description	Written by	Date
v1.0	Initial edition	Stan Lee	11 th , May, 2013