

NEMTEK
GROUP OF COMPANIES



MERLIN STEALTH MASTER - Electric Fence Energizer

INSTALLERS MANUAL

Revision 1.1
30/1/2009

MERLIN STEALTH: INSTALLERS MANUAL Table of Contents

INTRODUCTION.....	3-4
CONSIDERATIONS IN A NETWORKED ENERGIZER.....	5
DEFAULTING THE MASTER AND SLAVE ENERGIZERS.....	6
CONVERTER CARD SETTINGS.....	7-8
CONNECTING THE NETWORK.....	8
PROGRAMMING THE NETWORK.....	9
PROGRAMMING INDIVIDUAL ENERGIZERS.....	10
NETWORKING EXAMPLES.....	11-13

INTRODUCTION

This manual must read and used in conjunction with the Merlin Stealth Installer manual.

The Merlin Stealth Energizer™ range of energizers are configurable to be part of a networked security system. This enables control and monitoring of multiple energizers from one central location or from any location in the world with internet access.

There is no better electric fence security solution than multiple energizers being connected to different portions of a perimeter fence. Redundancy can be incorporated and bypassing the system becomes a lot more difficult. This necessitates the control of output energy and synchronization of energizer pulsing in order to avoid potentially hazardous conditions.

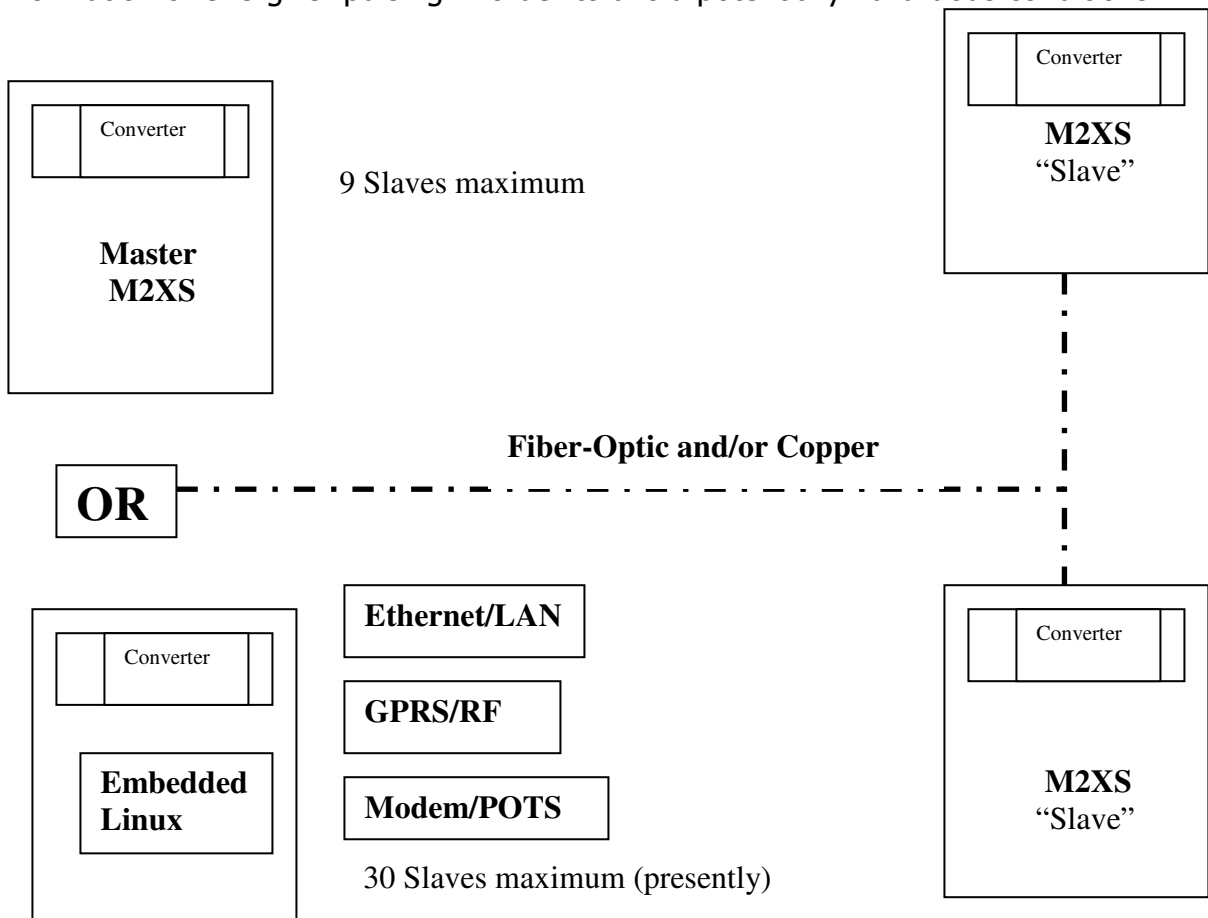

In order to facilitate the installation process, and cater from simple to extremely complex perimeter security requirements, Nemtek offers a range of products that can be combined to provide an integrated security solution. This also enables integration into other security systems such as access control and CCTV systems.

The currently available building blocks are:

Energizer/Controller Related

- Merlin M1XS and M2XS range of energizers. The fundamental building block of an electric fence. No special software is required when changing from a single energizer system to a networked system with multiple energizers. The same generic building block is used.
- Merlin Master M25S and Master M28S. Used for networking up to ten energizers M2XS energizers. Keypad located at master gives fence indication of twenty zones. Global and specific commands can be issued from this keypad. Slaves may use individual keypads as well.
- Merlin embedded linux controller platform. This provides total accessibility to individual or networked energizers. Permits energizers to become part of a local area network or to be accessed remotely. A range of communication protocols have been incorporated to provide flexibility / security and connectivity. Visit www.nemtek.com for more information and contact details.

Communication Related

- Merlin Stealth RS485/RS232 converter board.
- Merlin Stealth Fiber-Optic/RS485/RS232 converter board.

The remainder of this document discusses the installation of the Merlin M25 and M28 Stealth Master energizers in conjunction with standard Merlin Stealth Energizers. However, the networking principals remain the same. An installation using a Master controller can easily be upgraded to an embedded Linux platform controller.

Considerations in a Networked Energizer System.

The energizers and controller need to be physically connected. **The medium of choice is fiber-optics**, particularly in areas of high lightning incidence. The alternative is a wire based solution using RS485. It is possible to use a combination of both fiber and copper.

The Physical Layout of the Network:

The fundamental questions to be asked are:

1. Does my budget allow for fiber-optics throughout the network?
2. What is the maximum distance between any two network components? What number of network components are involved?
3. Is the loss of the communication network between any two network components allowed to influence the operation of any of the other components? This question is both security and budget related.

In relation to these questions consider the following:

1. Fiber-optics is the medium of choice from a lightning perspective. It is also ideal for data communication such as video signals. The cost of increasing the number of fibers in a cable is not prohibitive. Have a holistic view of access control, CCTV, electric fencing etc.
2. RS485 has a limit of 1200m before repeaters are required. RS485 has a physical limitation of 32 devices before some buffering is required. Unlike RS485, fiber-optics is always configured point to point with only two devices being connected. The standard Nemtek fiber-optic components have a range of 3km. (It is possible to extend this to 20km.)
3. In order to reduce costs, it is possible to use a single copper cable or optical fiber cable to connect all the network components. The disadvantage of such a system is that if the cabling is damaged communication is lost with all devices in the network. It is also possible to configure the network as a hub with network components being individually cabled to some central location. It is possible to use a combination of the different options (see network examples).

DEFAULTING THE ENERGIZERS

Before the energizers can be configured into a network **all** energizers have to be put into their factory default condition.

The Master energizer can only be defaulted with a 20 zone Keypad and the Slave energizer can be defaulted only with a 1 or 2 zone Keypad.

To default an energizer proceed as follows:

- 1) Disconnect the Mains from the energizer.
- 2) Disconnect the Battery from the energizer.
- 3) Reconnect the Battery and the Mains.
- 4) Within one minute after reconnecting the Battery and Mains enter the **default code 2389#** on the Keypad.
- 5) The unit should beep four times to confirm that the code is accepted.

If at some later stage the network has to be expanded with additional energizers, it will be necessary to default the additional as well as all old energizers in the network before the network can be reprogrammed.

CONVERTER CARD SETTINGS

There are two converter cards available for the communication interface between the energizers.

- 1) The Stealth RS 485 converter card.
The card converts RS485 to RS 232.
- 2) The Stealth Fibre Optic converter card.
This card converts:
 - a) RS 232 to fibre optics.
 - b) RS 485 to fibre optics.The selection between a) or b) is made with a jumper (JP3) on the converter card.
Please note that a single card can not convert from fibre optics to RS 232 and simultaneously convert to RS 485.

The converter cards have Jumpers (JP), which must be set correctly to make the network operate properly.

THE STEALTH RS-485 CONVERTER CARD

This card has only one jumper (JP1) which is used to correctly terminate the impedance of card and cable (twisted pair and earth-screen with a 120 Ohm characteristic impedance). For this reason it must be inserted at the first and the last network component of the RS 485 system.

The jumper (JP1) must not be inserted on the converter cards which are connected between the first and the last card.

THE STEALTH FIBRE OPTIC CONVERTER CARD

This card has three jumpers (JP1, JP2 and JP3).

JP1 is used on the card to repeat the optical signal i.e. anything received on the optical Rx port is immediately transmitted on the Tx port. To prevent that a message is repeated endlessly JP1 is never inserted on the Master controller. Jp1 is used normally on Slave units in the Daisy chained systems.

To decide if Jumper 1 should be inserted ask the question if the converter does not repeat the signal will a message from the Master reach the Slaves and will a message from the Slaves reach the Master. If the repeating is required insert JP1.

JP 2 is used on the card to correctly terminate the impedances of card and cable. It must be inserted when the card is the first or the last network component of the RS 485 system.

Do not use the jumper when the card is used for a RS 232 system or if it is used between the first and last network component in the RS 485 system.

JP3 selects if the card will be used in a RS 232 network or in a RS 485 network. When the jumper is inserted between position 1 & 2 the RS 485 option is selected. When the jumper is inserted between position 2 & 3 the RS 232 option is selected.

CONNECTING THE NETWORK

Until some experience has been gained with the system it is better to network all the network components in the same room. After programming and testing the system, the components can be installed on site.

Once programmed all parameters are stored in non-volatile memory. Disconnecting the mains and batteries will not change the stored data.

- 1) Ensure that mains is available for the energizer.
- 2) Disconnect the battery from the energizer.
- 3) Install all converter cards (if required) on the energizers.
- 4) Ensure that all jumpers are inserted correctly on the converter cards
- 5) Connect all fibre optic and RS 485 cables between the energizers and connect the RS 232 connection to the energizers.
- 6) Connect the 12Vdc Aux power from the energizer to the converter card.
- 7) Connect the 20 zone Keypad to the Master energizer.
- 8) Connect the 2 zone Keypads to the Slave energizers (if not used one is required for defaulting the Slave units.
- 9) Bypass the tamper switches on the energizers by inserting a jumper across JP1. High Voltages are present on the electronics ensure that one does not touch the electronic components with the tamper switch bypassed.

PROGRAMMING THE NETWORK

- 1) Default all the energizers as described under defaulting the energizer.
- 2) With all the network connections made and with the batteries disconnected, switch on the mains supply to all energizers.
- 3) Enter programming mode on the Master energizer with the key sequence **012345*0#**
The keypad will beep 7 times to acknowledge that the energizer is now in programming mode.
- 4) Select the type of energizer network:
 - Synchronized enter the key sequence **440#**
 - Non Synchronized enter the key sequence **441#**
- 5) After a few seconds the Master Keypad will start flashing the number 2 Led (the Master is always no 1 in the system) and the keypad buzzer will prompt for the information from the first Slave unit.
- 5) Connect a standard keypad to the first Slave unit.
- 6) Disconnect and reconnect the mains to this unit and enter **2389#** on the keypad. The keypad will beep 4 times to confirm that the code is accepted.
- 7) Take the first Slave into programming mode by entering **012345*0#**, the keypad will beep 7 times to acknowledge that it went into programming mode.
- 8) Ensure that the Master Keypad is still flashing 2 and if so then enter **448#** on the keypad of Slave1.
- 9) The B led on Slave 1 will start flashing after a few seconds then press ***#** on the Slave keypad to take it out of programming mode.
Number 3 will start flashing on the Master Keypad indicating that it is waiting for the information from Slave 2.
- 10) Repeat point 5 to 10 for programming the other Slave units (maximum 9 units) then enter ***#** on the Master Keypad to take it out of programming mode.

The system is now programmed, it is advisable to test if the Slave energizers will obey commands from the Master keypad and that alarms on the Slave energizers will show on the Master Keypad.

If a synchronized system was selected ensure that the Slave units will synchronize to the Master energizer and that they will go to low voltage mode if they are out of sync with the Master(see Stealth Master User manual).

Do not forget to remove the tamper switch bypass.

MERLIN STEALTH MASTER Programming the energizers

PROGRAMMING THE INDIVIDUAL ENERGIZERS

After the network is programmed the Master and Slave units can now individual be programmed to suit the requirements i.e. gate delay times, siren on times, fence alarm voltage etc.

If at some stage the network has to be reprogrammed these individual setting will fall back to the factory setting when the units are defaulted and have to be reprogrammed.

CAUTION

The Merlin Stealth Range, when programmed to be part of a synchronized energizer network: configures the energizer energy output with the assumption that only one other correctly programmed energizer, of the same network, may be touched simultaneously and still remain within the current limited energizer limits as defined in the IEC 60335-2-76

In other words if a synchronized work is selected the networking program will assume that a person can touch two fences at the same time and to stay legal the output energy is reduced during the network programming to half of the maximum energy of the energizer.

If three fences supplied by three different energizers of the same synchronized network would be within 2.5 meter of each other, the output energy of each of the energizers would have to be individually reprogrammed to one third of the maximum energy of the energizers to stay legal.

If an electric fence of a synchronized network is more than 2.5 meter away from other electric fences the output energy of the energizer supplying that fence can be individual reprogrammed to the maximum output of the energizer.

Refer to the appropriate regulations and laws pertaining to the installation of electric fences.

MERLIN STEALTH MASTER

Networking examples

RS 232 NETWORKED

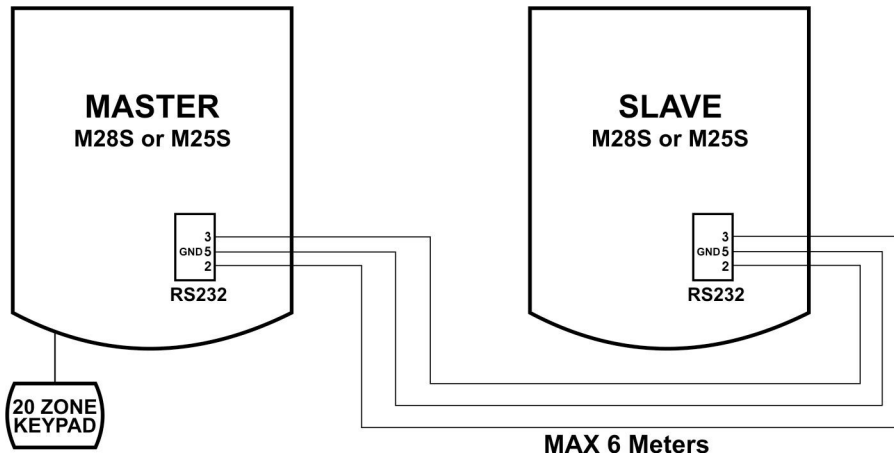

Units : One Master and One Slave
 Zones : Maximum 4 Zones
 Cable : Twisted pair and Earth-Screen (120 Ohm)
 Cable Length : Maximum 6 Meters
 Housing : In same room or building

RS 485 NETWORKED

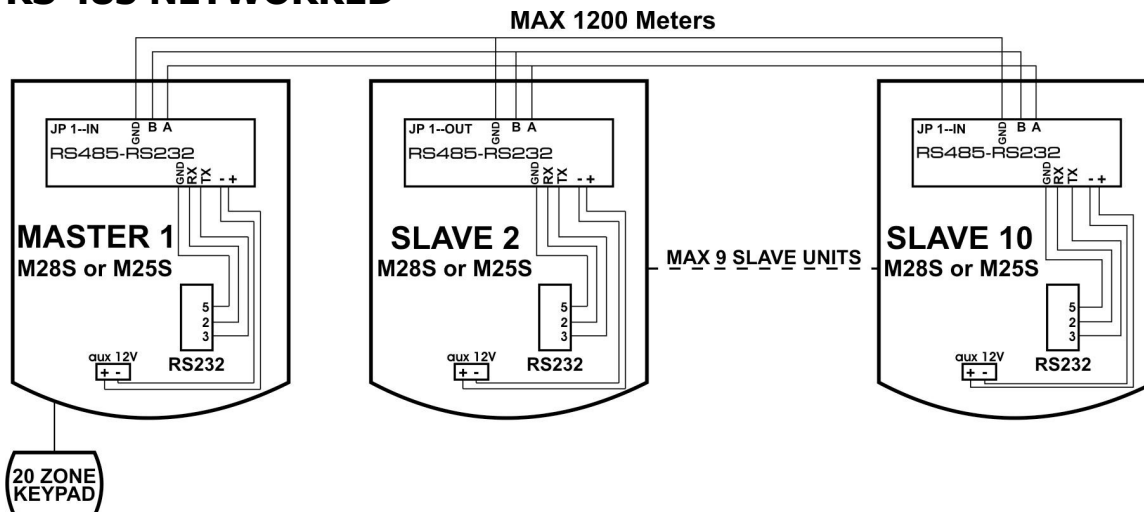

Units : One Master and Maximum 9 Slaves
 Zones : Maximum 20 Zones
 Cable : Twisted pair and Earth-Screen (120 Ohm)
 Cable Length : Overall Length Maximum 1200 Meters
 RS485-RS232 Card : JP1 Installed only on first and last unit

MERLIN STEALTH MASTER

Networking examples

RS 484 NETWORKED WITH EXTENDED DISTANCE

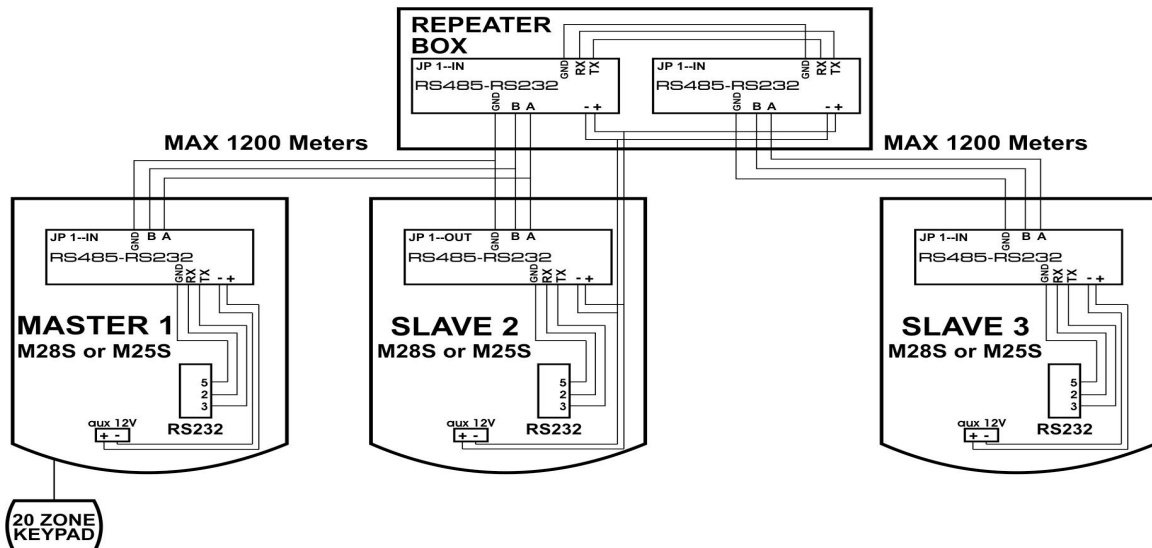

Units : One Master and Maximum 9 Slaves
 Zones : Maximum 20 Zones
 Cable : Twisted pair and Earth-Screen (120 Ohm)
 Cable Length : Overall Length Maximum 1200 Meters
 between Repeater and Master or Slave

RS485-RS232 Card : JP1 Installed only on first and last unit and on both units in the repeater

FIBRE OPTIC DAISY CHAINED

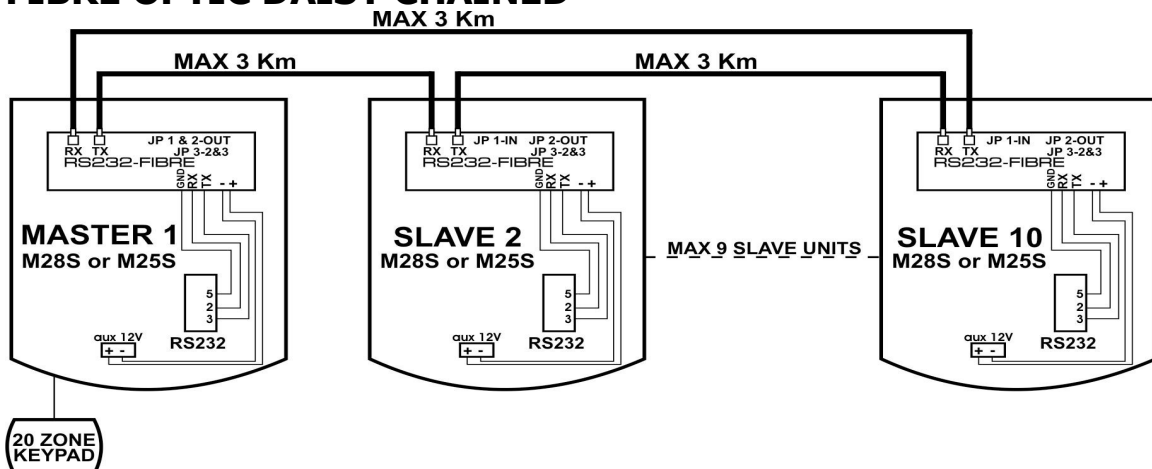

Units : One Master and Maximum 9 Slaves
 Zones : Maximum 20 Zones
 Fibre : Fibre Optic cable
 Cable Length : Maximum 3000 Meters between
 Master and Slave or Slave and Slave

RS232-FIBRE CARD : JP 1 Installed only on Slave units
 JP 2 not installed on all units
 JP 3 in position 2 & 3 on all units

MERLIN STEALTH MASTER

Networking examples

FIBRE OPTIC STAR CONNECTED

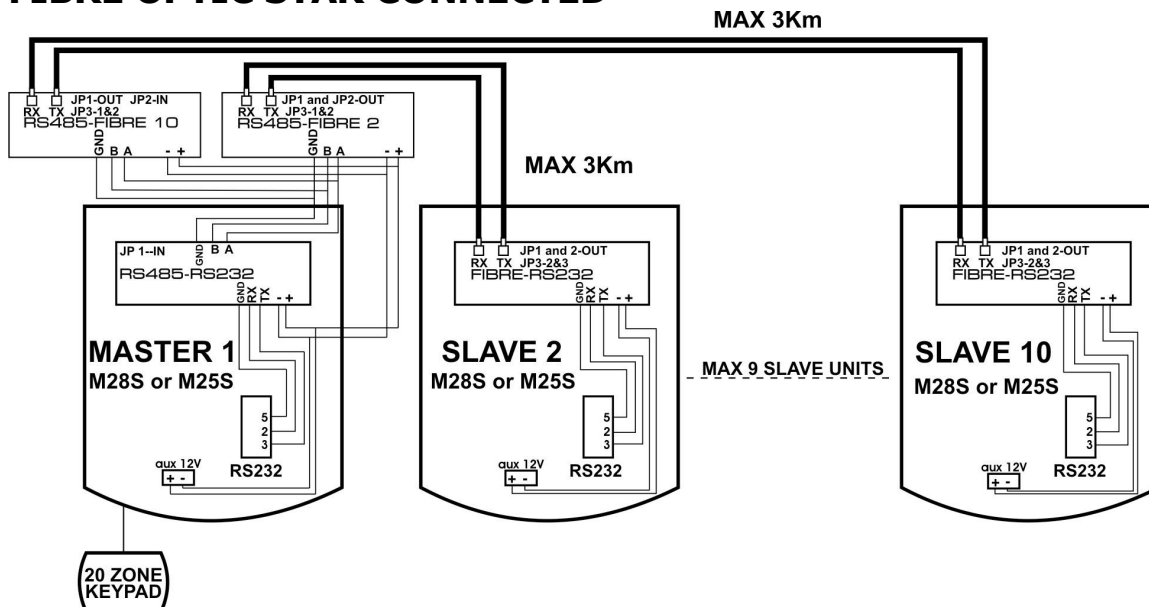

Units : One Master and Maximum 9 Slaves
 Zones : Maximum 20 Zones
 Cable : Twisted pair and Earth-Screen (120 Ohm)
 Fibre Length : Maximum 3000 Meters between
 Master and Slave

RS485-RS232 Card : JP 1 Installed
 RS485-FIBRE Card : JP 3 in position 1&2 on all units
 JP 2 installed on last unit only
 FIBRE-RS232 Card : JP 3 in position 2&3 on all units
 JP 1 and JP 2 not installed on all
 units

FIBRE/RS485 NETWORKED

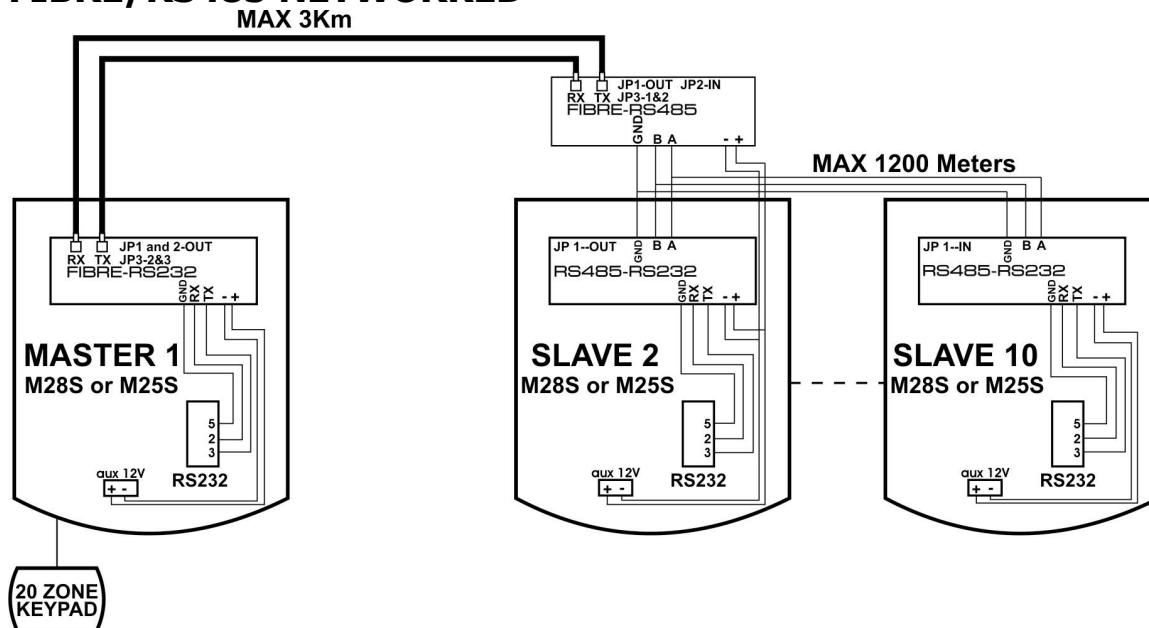

Units : One Master and Maximum 9 Slaves
 Zones : Maximum 20 Zones
 Cable : Twisted pair and Earth-Screen (120 Ohm)
 Cable Length : Overall length Maximum 1200 Meters
 Fibre Length : Maximum 3000 Meters

RS485-RS232 Card : JP 1 Installed only on last unit
 FIBRE-RS485 Card : JP 3 in position 1&2
 JP 2 installed and JP 1 not installed
 FIBRE-RS232 Card : JP 3 in position 2&3
 JP 1 and JP2 not installed