

INSTRUCTION MANUAL



AC/DC CLAMP ADAPTOR

KEW SNAP SERIES

MODEL 8113

KYORITSU ELECTRICAL INSTRUMENTS WORKS, LTD., TOKYO, JAPAN

Contents

	Page
1. Features.....	1
2. Specifications.....	2
3. Safety Notes.....	4
4. Instrument Layout.....	6
5. Measuring Method.....	7
5-1. Preparation.....	7
5-2. Measurements.....	7
5-2-1. DC Current Measurements.....	7
5-2-2. AC Current Measurements.....	9
5-2-3. Other Applications.....	10
6. Battery Replacement.....	10
7. Optional Accessories.....	11
7-1. Model 8021 KEW ENERGIZER.....	11
7-2. Model 8008 MULTI-TRAN.....	12

1. Features

- Model 8113 is a clamp-on AC/DC current/voltage converter that permits AC/DC current measurements from 1mA to 200A in conjunction with a voltmeter having 0.1mV resolution.
- It has 5A, 50A and 200A AC/DC measuring ranges. Output voltage is 500mV full scale for 5/50A ranges and 200mV for 200A range. For current measurements, select a 200 mV multimeter (3-1/2 digit digital readout) range and 1mA will be indicated as 0.1mV and 199.9A as 199.9mV for the clamp adaptor 5A and 200A ranges respectively. Therefore, Model 8113 allows you to make a wide range of current measurements from very low current equipment to high current switch box.
- In conjunction with a true RMS multimeter, it is also possible to measure a rectified current or even AC on DC currents.
- DC coupled, input waveform appears at the output jack without distortion. This will permit waveform observation on the oscilloscope.
- A wide frequency range of DC to 1kHz.
- Operates on two 1.5 V SUM-3 batteries or equivalent only.
- Housing case is made of UL listed fire retardant plastic material.

2. Specifications

Output Voltage:

	Measuring Ranges	Output
DC Current	0— 5A DC	0—500.0mV DC(100mV/A)
	0— 50A DC	0—500.0mV DC(10mV/A)
	0—200A DC	0—200.0mV DC(1mV/A)
AC Current	0— 5A AC	0—500.0mV AC(100mV/A)
	0— 50A AC	0—500.0mV AC(10mV/A)
	0—200A AC	0—200.0mV AC(1mV/A)

Accuracy:

	Measuring Ranges	Accuracy
DC Current	0— 5A DC	$\pm(1.5\%rdg+5mA)$
	0— 50A DC	$\pm(1.0\%rdg+0.02A)$
	0—150A DC	$\pm(1.5\%rdg+0.2A)$
	150—200A DC	$\pm3.0\%rdg$
AC Current	0— 5A AC	$\pm(2.0\%rdg+5mA)$ DC-1kHz
	0— 50A AC	$\pm(1.5\%rdg+0.04A)$ DC-1kHz
	0—150A AC	$\pm(2.0\%rdg+0.5A)$ DC-1kHz
	150—200A DC	$\pm3.5\%rdg$ DC-1kHz

(Above accuracies are specified for + 18°C to + 23°C at < 80% relative humidity)

Operating

Temperature

& Humidity : -10°C — +50°C at <85% relative humidity

Storage

Temperature

& Humidity : -20°C — + 60°C at <75% relative humidity

Load

Resistance : >1k Ω

Power Supply : 2×1.5V SUM-3 battery or equivalent

Low Battery

Warning :

Power indication lamp flashes at a longer interval when batteries become exhausted and finally stops flashing at approx. 2.2V.

Current

Consumption : Approx. 10mA

Battery Life : 90hours on continuous use(for manganese batteries)

Overload

Protection : < 500A AC, DC

Withstand

Voltage :

1000V AC for one minute between electrical circuit and housing case or metal section of transformer jaws.

Insulation

Resistance :

>10M Ω at 1000V between electrical circuit and housing case or metal section of transformer jaws.

Conductor

Size : < approx.19mm

Dimensions : 180(L)×536(w)×31.4(D)mm

Weight : Approx. 170g . (batteries included)

Accessories : (included)

Output cord Model 7061, 2×1.5V SUM-3(R-6)battery or equivalent, carrying case, instruction manual (optional)

KEW Energizer Model 8021

KEW Multitrans Model 8004&8008

3. Safety Notes

This instruction manual contains warnings and safety rules that must be observed by the user to ensure safe operation of the instrument and retain it in safe condition.

Therefore, read these operating instructions thoroughly and completely before using the instrument.

Pay particular attention to all **WARNINGS** and **CAUTIONS** in this instruction manual.

WARNING indicates warning to avoid an electrical shock and **CAUTION** indicates cautions to avoid damage to the instrument and make accurate measurements.

WARNINGS

1. If the instrument shows the following conditions, do not try to make measurements and have the instrument checked for inspection or repair.

Instrument shows visual damage.

Test leads are damaged.

Instrument can not be operated for intended measurements.

Instrument has been stored for long period of time under abnormal conditions.

Instrument has been subjected to severe shocks and vibrations.

2. The transformer jaws are made of metal and their tips are not insulated.

Be especially careful about the hazard of possible shorting where the equipment under test has exposed metal parts.

3. Do not make measurements in an explosive atmosphere (i.e. in the presence of flammable gasses or fumes, vapor or dust)
4. Never ground yourself when conducting electrical tests. Do not touch exposed metal pipes, outlets, fixtures, etc, which

might be at ground potential. Keep your body isolated from ground by using dry clothing, rubber shoes, rubber mats, or any approved insulating material.

5. DO NOT make battery replacement with power switch set to ON position and test leads connected to instrument.
6. DO NOT use Model 8113 on a circuit with a voltage of higher than 600V AC.
7. DO NOT expose it to the direct sun, extremes of temperature and humidity or dew fall.

CAUTIONS

1. When not in use for a long period of time, place the instrument in storage after removing the batteries from it.
2. Never make measurements if the instrument, the test leads or your hand is wet.
3. Calibration and repair of any instrument should only be performed by qualified and trained service technicians.
4. Do not install substitute parts or perform any unauthorized modification of the instrument. Return the unit to Kyoritsu or your distributor for repair.
5. Use a damp cloth and detergent for cleaning the case of the on the instrument. Do not use abrasives or solvents.
6. Always set the Range Selector Switch to the OFF position after use.
7. The instrument must be used by a competent, trained person and operated in strict accordance with the instructions. Kyoritsu will not accept liability for any damage or injury caused by misuse or noncompliance with the instructions or safety procedures. It is essential to read and understand the safety rules contained in the instructions. They must be observed when using the instrument.

4. Instrument Layout

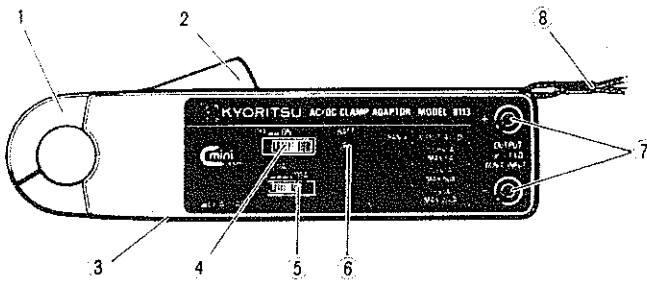

1 Transformer Jaws

Pick up current flowing through the conductor.

2 Jaw Trigger

Operates the transformer jaws. Press to open the jaws.

3 DC Zero Adj. Knob

Zero adjusts on DC current ranges.

4 Power Switch

Turns power on and off.

5 Range Selector Switch

Selects 2A, 20A or 200A range position.

6 Battery Indicator

LED starts flashing when the power switch is turned on. It flashes at a longer interval when the battery voltage becomes exhausted and finally stops flashing at approx. 2.2V. Also, serves as a power on and low battery indicator.

7 Output Terminals

Output voltage proportional to input current is available from these terminals.

8 Hand Strap

Prevents the instrument from slipping off the hand during use.

— 6 —

5. Measuring Method

BEFORE USING THE ADAPTOR, READ THE SAFETY NOTES CAREFULLY AND THOROUGHLY.

5-1. Preparation

- (1) Remove the battery compartment cover and install the batteries. Refer to section 6 for battery replacement.
- (2) A DC voltmeter or AC voltmeter is required for DC or AC current measurement. Connect the output cords to the input terminals of the voltmeter. In case of DC current measurements, always insert the red banana plug into the plus (+) terminal and the black banana plug into the minus(−) terminal of any multimeter with an input impedance of at least 1 k Ω as shown in Fig. 1.

Fig. 1

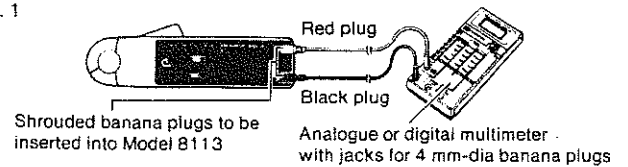

5-2 Measurements

Notes : ● The maximum diameter of a conductor under test is 19 mm.

Do not clamp onto a conductor larger than this size. Accurate measurements cannot be made where the 8113 is clamped onto a larger conductor with its transformer jaws not fully closed.

● To obtain maximum accuracy, the transformer jaws are precisely adjusted. Exercise extreme care to avoid shock, vibration or excessive force when using the clamp adaptor.

5-2-1 DC Current Measurements (2A, 20A & 200A ranges)

- (1) With the power switch set to ON position, select the desired range.

— 7 —

(2) Refer to Table 1 for output voltage against input. Set the multimeter to the appropriate range. When using a digital multimeter (3-1/2 digit), select the 200mV DC or 2V DC range.

Table 1

Range Switch Position	Output Voltage
2A DC	0–500.0mV (100mV/A) against 0–5A DC input
20A DC	0–500.0mV (10mV/A) against 0–50A DC input
200A DC	0–200.0mV (1mV/A) against 0–200A DC input

Note : Measurements can be made up to 5A at the 2A range position and up to 50A at the 20A range position.

(3) Before making measurements, adjust “DC A 0 Adj. control knob” to zero output. For accurate measurements, it is a recommended practice to make this zero adjustment for every measurement. It is also necessary to make the zero adjustment after every range changing as it may cause the instrument to be off zero.

(4) Press the trigger to open the transformer jaws and clamp onto one conductor only. Since the current measured will be displayed as voltage, read it in amperes according to each range. For example, take the reading as follows using a 3-2/1 digit digital multimeter.

Table 2

Range Switch Position	Digital Tester Readings		Currents measured
	200mV Range	2V Range	
2A	50.0mV	0.050V	0.50A
	100.0mV	0.100V	1.00A
	—	0.500V	5.00A
20A	50.0mV	0.050V	5.0A
	100.0mV	0.100V	10.0A
	—	0.500V	50.0A
200A	50.0mV	0.050V	50A
	100.0mV	0.100V	100A

Note : The display may slightly flicker on the 2A range because of high sensitivity when the 200mV range is used.

(5) In case of DC current measurement, output is positive when the current flows from the upside to the underside of the clamp adaptor as shown in Fig.2.

Fig. 2

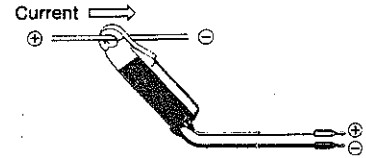

5-2-2 AC current measurements (2A, 20A&200A ranges)

Note : For AC current measurements, input waveform will be available at the output jack, DC coupled and without distortion. Therefore, true RMS measurements would be possible using a true RMS reading AC Voltmeter. In case of non-sinusoidal input current, the reading may not be accurate when the 8113 is connected to an average responding AC voltmeter calibrated in RMS of a sine wave.

(1) With the power switch set to ON position, select the desired range.

(2) Refer to Table 3 for output voltage against input current.

Table 3

Range Switch Position	Output Voltage
2A	0–500.0mV against 0–5A AC (100mV/A)
20A	0–500.0mV against 0–50A AC (10mV/A)
200A	0–200.0mV against 0–200A AC (1mV/A)

Note : Measurements can be made up to 5A at the 2A range position and up to 50A at the 20A range position.

(3) Press the trigger to open the transformer jaws and clamp and onto one conductor only. The current measured will be displayed as voltage. Take the reading in amperes by referring to Table 2 for voltage/current conversion.

NOTE : TO MEET VARIOUS APPLICATION NEEDS, THE 8113 IS DESIGNED TO BE HIGHLY SENSITIVE ON THE 2A RANGE, RESULTING IN RESIDUAL OUTPUT NOISE EQUIVALENT TO $\pm 2\text{mV}$ APPROX. HOWEVER, THIS DOES NOT INDICATE ANY FAULTY CONDITION. IN CASE OF DC CURRENT, EARTH MAGNETISM AFFECTS MEASUREMENTS. THEREFORE, THE READING WILL SLIGHTLY VARY DEPENDING ON THE ORIENTATION OF THE 8113 IN USE. TO MAKE PRECISE MEASUREMENT, IT IS A RECOMMENDED PROCEDURE TO ZERO ADJUST THE 8113 EVERY TIME ITS ORIENTATION IS CHANGED.

5-2-3 Other applications

DC coupled and without distortion input waveform appears on the output terminal of the instrument. This will permit current waveform observation on the oscilloscope. When connected to a recorder, it will also allow for a continuous recording of input current. As a current sensor, the 8113 may also permit a wide range of other applications.

6. Battery Replacement

When the battery indicator LED blinks at a longer interval and finally stops blinking, replace the battery as indicated below.

CAUTION : Do not replace the battery while measuring.

- (1) Remove the test lead from the instrument and set the Power switch to the off position.
- (2) Loosen the screws of the battery compartment cover at the back of housing. And then slide and remove the battery compartment cover.

Note : Do not loosen the screws completely to the end in order to avoid losing them.

- (3) Replace the battery with new one.
- (4) Push the battery compartment cover and fasten the screws firmly.

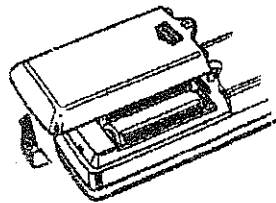

Fig.3

7. Optional Accessories

7-1 Model 8021 KEW ENERGIZER

Model 8021 ENERGIZER permits Model 8113 to make AC current and voltage measurements of household electrical appliances which are normally furnished with "twin" conductor line cords and plugs for household power outlets. Incorporated into this energizer is a coil to multiply the current by 1, 5 and 10 and a voltage check terminal.

Fig. 4

- (1) As shown below, Model 8113 clamped onto "1X" position of the ENERGIZER is to measure current flowing through a twin conductor line cord (up to 10A AC) (Fig.4).

Connection to AC Power Outlet

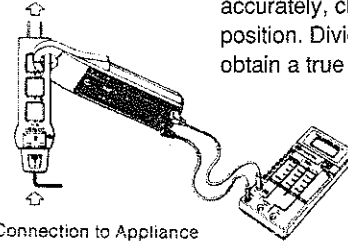

Connection to Appliance under Test (up to 10A AC max. load current)

- (2) To measure a low current more accurately, clamp onto "5X" or "10X" position. Divide the reading by 5 or 10 to obtain a true current value.

7-2 Model 8008 MULTI-TRAN

Model 8008 MULTI-TRAN is designed to measure AC current higher than 200A or large bus-bars (up to 150X100mm) and conductors(up to 100mm diameter).

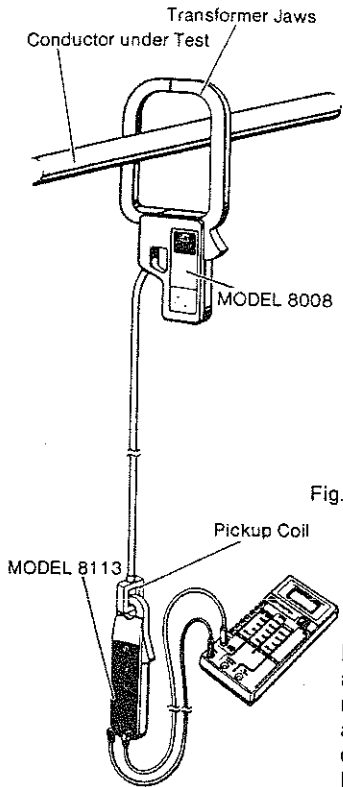

- (1) As shown in Fig.5, open the transformer jaws of Model 8113 and close them over the pickup coil of Model 8008 MULTI-TRAN to measure up to 2000A AC.
- (2) Since the input to output ratio is 10 to 1, multiply the output by 10 and take the current reading (Fig.5).

Fig. 5

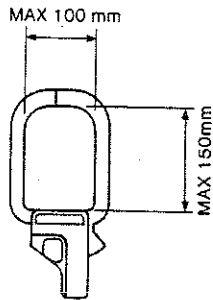

Model 8004 MULTI-TRAN is also available for AC current measurements up to 1000A on a conductor of max. 55mm diameter.

Note : Model 8004 and 8008 are not designed for DC current measurements.

Kyoritsu reserves the right to change specifications or designs described in this manual without notice and without obligations.