

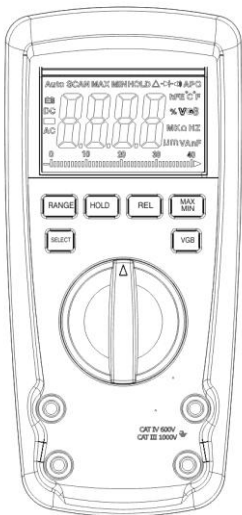

MT1880IV

Industrial Multimeter

User Manual



Introduction

This meter measures VGB , AC/DC Voltage, AC/DC Current, Resistance, Capacitance, Frequency (electrical & electronic), Diode Test, and Continuity plus. Proper use and care of this meter will provide many years of reliable service.

Safety



This symbol adjacent to another symbol, terminal or operating device indicates that the operator must refer to an explanation in the Operating Instructions to avoid personal injury or damage to the meter.

WARNING

This WARNING symbol indicates a potentially hazardous situation, which if not avoided, could result in death or serious injury.

CAUTION

This CAUTION symbol indicates a potentially hazardous situation, which if not avoided, may result damage to the product.

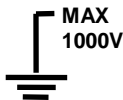

This symbol advises the user that the terminal(s) so marked must not be connected to a circuit point at which the voltage with respect to earth ground exceeds (in this case) 1000 VAC or VDC.



This symbol adjacent to one or more terminals identifies them as being associated with ranges that may, in normal use, be subjected to particularly hazardous voltages. For maximum safety, the meter and its test leads should not be handled when these terminals are energized.



This symbol indicates that a device is protected throughout by double insulation or reinforced insulation.

PER IEC1010 OVERVOLTAGE INSTALLATION CATEGORY

OVERVOLTAGE CATEGORY I

Equipment of OVERVOLTAGE CATEGORY I is equipment for connection to circuits in which measures are taken to limit the transient overvoltages to an appropriate low level.

Note – Examples include protected electronic circuits.

OVERVOLTAGE CATEGORY II

Equipment of OVERVOLTAGE CATEGORY II is energy-consuming equipment to be supplied from the fixed installation.

Note – Examples include household, office, and laboratory appliances.

OVERVOLTAGE CATEGORY III

Equipment of OVERVOLTAGE CATEGORY III is equipment in fixed installations.

Note – Examples include switches in the fixed installation and some equipment for industrial use with permanent connection to the fixed installation.

OVERVOLTAGE CATEGORY IV

Equipment of OVERVOLTAGE CATEGORY IV is for use at the origin of the installation.

Note – Examples include electricity meters and primary over-current protection equipment

SAFETY INSTRUCTIONS

This meter has been designed for safe use, but must be operated with caution. The rules listed below must be carefully followed for safe operation.

1. **NEVER** apply voltage or current to the meter that exceeds the specified maximum:

Input Protection Limits	
Function	Maximum Input
V DC or V AC	1000VDC/750VAC rms
mA AC/DC	500mA 1000V fast acting fuse
A AC/DC	10A 1000V fast acting fuse (20A for 30 seconds max every 15 minutes)
Frequency, Resistance, Capacitance, Duty Cycle, Diode Test, Continuity	1000VDC/750VAC rms

2. **USE EXTREME CAUTION** when working with high voltages.
3. **DO NOT** measure voltage if the voltage on the "COM" input jack exceeds 1000V above earth ground.
4. **NEVER** connect the meter leads across a voltage source while the function switch is in the current, resistance, or diode mode. Doing so can damage the meter.
5. **ALWAYS** discharge filter capacitors in power supplies and disconnect the power when making resistance or diode tests.
6. **ALWAYS** turn off the power and disconnect the test leads before opening the covers to replace the fuse or batteries.

7. **NEVER** operate the meter unless the back cover and the battery and fuse covers are in place and fastened securely.

If the equipment is used in a manner not specified by the manufacturer, the protection provided by the equipment may be impaired.

Controls and Jacks

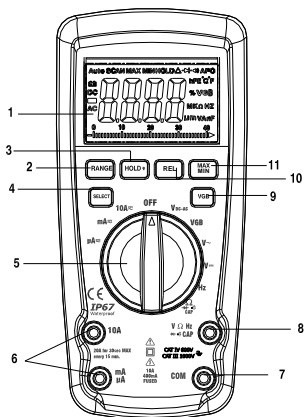

1. 4,000 count LCD display
2. RANGE button
3.  Backlight and Hold button
4. MODE button
5. Function switch
6. mA, μ A and 10A input jacks
7. COM input jack
8. Positive input jack
9. VGB
10. REL button
11. MAX/MIN button

Note: Tilt stand and battery compartment are on rear of unit.

Symbols and Annunciators

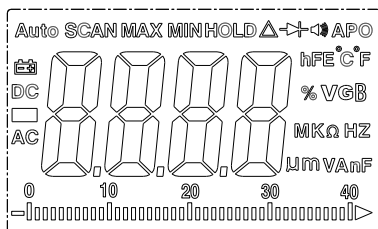

•))) Continuity

▶ Diode test

🔋 Battery status

n nano (10^{-9}) (capacitance)

μ micro (10^{-6}) (amps, cap)

m milli (10^{-3}) (volts, amps)

A Amps

k kilo (10^3) (ohms)

F Farads (capacitance)

M mega (10^6) (ohms)

Ω Ohms

Hz Hertz (frequency) V Volts

REL Relative

AC Alternating current AUTO Autoranging

DC Direct current HOLD Display hold

°F Degrees Fahrenheit °C Degrees Centigrade

MAX Maximum MIN Minimum

AUTO Auto Range
Timing symbol
Backlight
bargraph

Operating Instructions

WARNING: Risk of electrocution. High-voltage circuits, both AC and DC, are very dangerous and should be measured with great care.

1. ALWAYS turn the function switch to the **OFF** position when the meter is not in use.
2. If “OL” appears in the display during a measurement, the value exceeds the range you have selected. Change to a higher range.

DC VOLTAGE MEASUREMENTS

CAUTION: Do not measure DC voltages if a motor on the circuit is being switched ON or OFF. Large voltage surges may occur that can damage the meter.

1. Set the function switch to the “**DC**” position (V_{DC-AC}).
2. Insert the black test lead banana plug into the negative **COM** jack. Insert the red test lead banana plug into the positive **V** jack.
3. Touch the black test probe tip to the negative side of the circuit. Touch the red test probe tip to the positive side of the circuit.
4. Read the voltage in the display.

VGB (VAC ONLY)

“ Ghost” voltage means voltage that appears on a conductor that is not actually energized. This often occurs on spare conductors in a conduit or cable. The spare conductors are very close to the live conductors. The capacitance between the live and spare conductors causes the “ghost” voltage to appear when the measurement is made with a high impedance meter. A DMM with 10 M Ω input impedance is one example of a high impedance meter. The VGB network is connected across the input terminals to provide low input impedance. Low input impedance is used to reduce any “ghost” voltage to very small levels, about 2 to 5 volts.

By engaging the VGB (a bleep will sound every 3 seconds to confirm VGB is engaged) mode your DMM can distinguish a ghost voltage by effectively ‘Killing’ it. If the voltage being measured is a true (hard) voltage(10-15 Vac) the multimeter will automatically switch to true voltage measurement mode .

AC VOLTAGE MEASUREMENTS

CAUTION: Do not measure AC voltages if a motor on the circuit is being switched ON or OFF. Large voltage surges may occur that can damage the meter.

1. Set the function switch to “**AC**” position(V_{\sim} or V_{DC-AC}).
2. Insert the black test lead banana plug into the negative **COM** jack. Insert red test lead banana plug into the positive **V** jack.
3. Touch the black test probe tip to the neutral side of the circuit. Touch the red test probe tip to the “hot” side of the circuit.
4. Read the voltage in the display

AC/DC CURRENT MEASUREMENTS

CAUTION: Do not make 10A current measurements for longer than 30 seconds. Exceeding 30 seconds may cause damage to the meter and/or the test leads.

1. Insert the black test lead banana plug into the negative **COM** jack.
2. For current measurements up to 4000 μ A AC/DC, set the function switch to the **μ A** position and insert the red test lead banana plug into the **μ A/mA** jack, press mode button to select AC or DC.
3. For current measurements up to 400mA DC, set the function switch to the **mA** position and insert the red test lead banana plug into the **μ A/mA** jack ,press mode button to select AC or DC.
4. For current measurements up to 10A DC, set the function switch to the **10A** position and insert the red test lead banana plug into the **10A** jack, press mode button to select AC or DC.
5. Remove power from the circuit under test, then open up the circuit at the point where you wish to measure current.
6. Touch the black test probe tip to the negative side of the circuit. Touch the red test probe tip to the positive side of the circuit.
7. Apply power to the circuit.
8. Read the current in the display.



RESISTANCE MEASUREMENTS

WARNING: To avoid electric shock, disconnect power to the unit under test and discharge all capacitors before taking any resistance measurements. Remove the batteries and unplug the line cords.



1. Set the function switch to the **Ω CAP**  position.
2. Insert the black test lead banana plug into the negative **COM** jack. Insert the red test lead banana plug into the positive **Ω** jack.
3. Press the **MODE** button to indicate “ **Ω** ” on the display.
4. Touch the test probe tips across the circuit or part under test. It is best to disconnect one side of the part under test so the rest of the circuit will not interfere with the resistance reading.
5. Read the resistance in the display.

CONTINUITY CHECK

WARNING: To avoid electric shock, never measure continuity on circuits or wires that have voltage on them.

1. Set the function switch to the **Ω CAP**  position.
2. Insert the black lead banana plug into the negative **COM** jack. Insert the red test lead banana plug into the positive **Ω** jack.
3. Press the **MODE** button to indicate “  ” and “ **Ω** ” on the display
4. Touch the test probe tips to the circuit or wire you wish to check.
5. If the resistance is less than approximately 30Ω , the audible signal will sound. If the circuit is open, the display will indicate “**OL**”.

DIODE TEST

1. Set the function switch to the **Ω CAP**  position.
2. Insert the black test lead banana plug into the negative **COM** jack and the red test lead banana plug into the positive **V** jack.
3. Press the **MODE** button to indicate “” and “**V**” on the display.
4. Touch the test probes to the diode under test.
Forward voltage will typically indicate 0.400 to 0.700V. Reverse voltage will indicate “**OL**”.
Shorted devices will indicate near 0V and an Open device will indicate “**OL**” in both polarities.

CAPACITANCE MEASUREMENTS

WARNING: To avoid electric shock, disconnect power to the unit under test and discharge all capacitors before taking any capacitance measurements. Remove the batteries and unplug the line cords.

1. Set the rotary function switch to the **Ω CAP**  position.
2. Insert the black test lead banana plug into the negative **COM** jack.
3. Insert the red test lead banana plug into the positive **V** jack.
4. Touch the test leads to the capacitor to be tested.
Read the capacitance value in the Display

FREQUENCY MEASUREMENT

1. Set the function switch to the Hz/Duty position.
2. Insert the black test lead banana plug into the negative (-) jack (COM) and the red test lead banana plug into the positive (+) jack (F).
3. Touch the test probe tips to the circuit under test.
4. Read the frequency in the display. The digital reading will indicate the proper decimal point, symbols (Hz, kHz, MHz) and value.

NOTE: Press the mode key to select the frequency or the duty cycle measuring.

SELECT BUTTON

1. To select DC/AC current or voltage or resistance/capacitance Diode/Continuity or Hz/duty

DATA HOLD BUTTON

The Data Hold function allows the meter to "freeze" a measurement for later reference.

1. Press the DATA HOLD button to "freeze" the reading on the indicator. The indicator "HOLD" will be appear in the display.
2. Press the DATA HOLD button to return to normal operation.
3. Press the DATA HOLD button to last 2 second, the blue back light function is enabled or disenabled.

RANGE BUTTON



When the meter is first turned on, it automatically goes into Auto Ranging. This automatically selects the best range for the measurements being made and is generally the best mode for most measurements. For measurement situations requiring that a range be manually selected, perform the following:

1. Press the RANGE button. The “AUTO” display indicator will turn off.
2. Press the RANGE button to step through the available ranges until you select the range you want.
3. Press and hold the RANGE button for 2 seconds to Exit the Manual Ranging mode and return to Auto Ranging.

MAX/MIN BUTTON

The meter displays the maximum or minimum value of input in the Max/Min mode. When Max/Min is pressed for the first time, the meter displays the maximum value. The meter displays the minimum value when it is pressed again. When Max/Min is pressed for the third time, the meter displays current value. The meter returns to normal operation when Max/Min is pressed and held for longer than one second. Press HOLD key in Max/Min mode makes the meter stop updating the maximum or the minimum value.

LOW BATTERY INDICATION

When the  icon appears alone in the display  , the battery should be replaced.

Maintenance

WARNING: To avoid electric shock, disconnect the test leads from any source of voltage before removing the back cover or the battery or fuse covers.

WARNING: To avoid electric shock, do not operate your meter until the battery and fuse covers are in place and fastened securely.

This MultiMeter is designed to provide years of dependable service, if the following care instructions are performed:

1. **KEEP THE METER DRY.** If it gets wet, wipe it off.
2. **USE AND STORE THE METER IN NORMAL TEMPERATURES.** Temperature extremes can shorten the life of the electronic parts and distort or melt plastic parts.
3. **HANDLE THE METER GENTLY AND CAREFULLY.** Dropping it can damage the electronic parts or the case.
4. **KEEP THE METER CLEAN.** Wipe the case occasionally with a damp cloth. DO NOT use chemicals, cleaning solvents, or detergents.
5. **USE ONLY FRESH BATTERIES OF THE RECOMMENDED SIZE AND TYPE.** Remove old or weak batteries so they do not leak and damage the unit.
6. **IF THE METER IS TO BE STORED FOR A LONG PERIOD OF TIME,** the batteries should be removed to prevent damage to the unit.

BATTERY INSTALLATION

WARNING: To avoid electric shock, disconnect the test leads from any source of voltage before removing the battery cover.

1. Turn power off and disconnect the test leads from the meter.
2. Open the rear battery cover by removing two screws (B) using a Phillips head screwdriver.
3. Insert the battery into battery holder, observing the correct polarity.
4. Put the battery cover back in place. Secure with the screws.

WARNING: To avoid electric shock, do not operate the meter until the battery cover is in place and fastened securely.

NOTE: If your meter does not work properly, check the fuses and batteries to make sure that they are still good and that they are properly inserted.

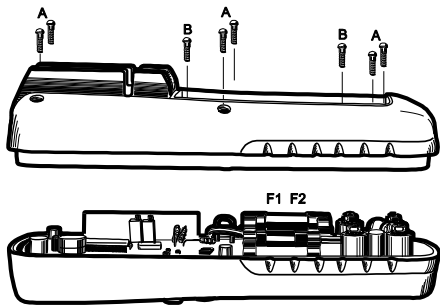

Specifications

DC Voltage (VDC)

Range	Resolution	Accuracy
400.0mV	0.1mV	$\pm 1.0\%$ of rdg ± 4 digits
4.000V	1mV	
40.00V	10mV	
400.0V	100mV	
1000V	1V	$\pm 1.2\%$ of rdg ± 4 digits

Input Impedance: 10M Ω .

Maximum Input: 1000V dc or 750V ac rms.

AC Voltage (VAC)

Range	Resolution	Accuracy
4.000V	1mV	$\pm 1.2\%$ of rdg ± 6 digits
40.00V	10mV	
400.0V	100mV	
750V	1V	$\pm 1.5\%$ of rdg ± 6 digits

All AC voltage ranges are specified from 5% of range to 100% of range

Input Impedance: 10M Ω .

AC Response: 50 Hz to 400Hz

Maximum Input: 1000V dc or 750V ac rms.

DC Voltage (VDC-AC)

Range	Resolution	Accuracy
0-400.0mV	0.1mV	$\pm 1.0\%$ of rdg ± 4 digits
4.000V	1mV	
40.00V	10mV	
400.0V	100mV	

1000V	1V	$\pm 1.2\%$ of rdg ± 4 digits
-------	----	-----------------------------------

Input Impedance: 10M Ω .

Maximum Input: 1000V dc or 750V ac rms.

AC Voltage (VDC-AC)

Range	Resolution	Accuracy
0.15V-4.000V	1mV	$\pm 1.0\%$ of rdg ± 6 digits
40.00V	10mV	
400.0V	100mV	
750V	1V	$\pm 1.2\%$ of rdg ± 6 digits

All AC voltage ranges are specified from 5% of range to 100% of range

Input Impedance: 10M Ω .

AC Response: 50 Hz to 400Hz

Maximum Input: 1000V dc or 750V ac rms.

DC Current (Auto-ranging)

Range	Resolution	Accuracy
400.0uA	0.1uA	$\pm 1.0\%$ of rdg ± 5 digits
4000uA	1uA	
40.00mA	10uA	
400.0mA	100uA	$\pm 1.2\%$ of rdg ± 5 digits
10A	10mA	$\pm 1.8\%$ of rdg ± 5 digits

Overload Protection: FF500mA / 1000V and F10A / 1000V Fuse.

Maximum Input: 4000uA dc on uA range
500mA dc on mA range
10A dc on 10A range.

AC Current (Auto-ranging)

Range	Resolution	Accuracy
400.0uA	0.1uA	$\pm 1.2\%$ of rdg ± 6 digits
4000uA	1uA	
40.00mA	10uA	
400.0mA	100uA	$\pm 1.5\%$ of rdg ± 6 digits
10A	10mA	$\pm 2.0\%$ of rdg ± 6 digits

All AC Current ranges are specified from 5% of range to 100% of range

Overload Protection: FF500mA/1000V and F10A/1000V Fuse.

AC Response: 50 Hz to 400 Hz

Maximum Input: 4000uA ac rms on uA

500mA ac rms on mA

10A ac rms on 10A range

Resistance [Ω] (Auto-ranging)

Range	Resolution	Accuracy
400.0 Ω	0.1 Ω	$\pm 1.2\%$ of rdg ± 4 digits
4.000k Ω	1 Ω	$\pm 1.2\%$ of rdg ± 2 digits
40.00k Ω	10 Ω	
400.0k Ω	100 Ω	
4.000M Ω	1k Ω	$\pm 1.5\%$ of rdg ± 8 digits
40.00M Ω	10k Ω	

Input Protection: 1000V dc or 750V ac rms.

Capacitance (Auto-ranging)

Range	Resolution	Accuracy
40.00nF	10pF	$\pm 5.0\%$ of rdg ± 20 dgts
400.0nF	0.1nF	$\pm 3.0\%$ of rdg ± 5 dgts
4.000uF	1nF	
40.00uF	10nF	
400.0uF	0.1uF	
4000uF	1 uF	$\pm 5.0\%$ of rdg ± 10 dgts

Input Protection: 1000V dc or 750V ac rms.

Frequency (Auto-ranging)

Range	Resolution	Accuracy
9.999Hz	0.001Hz	$\pm 1.2\%$ of rdg ± 3 dgts
99.99 Hz	0.01Hz	
999.9 Hz	0.1Hz	
9.999KHz	1 Hz	
99.99kHz	10Hz	
999.9kHz	100Hz	
9.999MHz	1kHz	$\pm 1.5\%$ of rdg ± 4 dgts

Sensitivity: $>0.5V$ RMS while $\leq 1MHz$;

Sensitivity: $>3V$ RMS while $>1MHz$;

Input Protection: 1000V dc or 750V ac rms.

Diode Test

Test current	Resolution	Accuracy
0.3mA typica	1 mV	$\pm 10\%$ of rdg ± 5 digits

Open circuit voltage: MAX. 2V dc

Overload protection: 1000V dc or 750V Ac rms.

Audible continuity

Audible threshold: Less than 30Ω Test current MAX. 0.3mA

Overload protection: 1000V dc or 750V Ac rms.

Store capacitance	2000
Enclosure	Double molded, waterproof
Shock (Drop Test)	6.5 feet (2 meters)
Diode Test	Test current of 0.9mA maximum, open circuit voltage 2V DC typical
Continuity Check	Audible signal will sound if the resistance is less than 30Ω (approx.), test current $<0.3\text{mA}$
Input Impedance	$>10\text{M}\Omega$ VDC & $>9\text{M}\Omega$ VAC
ACV Bandwidth	50Hz to 400Hz
Crest Factor	≤ 3 at full scale up to 500V, decreasing linearly to ≤ 1.5 at 1000V
Display	40,00 count backlit liquid crystal with bargraph
Overrange indication	"OL" is displayed

NON-CONTACT VOLTAGE (NCV) :

The NCV function works on any rotary switch position.

1. Test the detector on a known live circuit before use.
2. Hold the top of the meter very close to the voltage source as shown.
3. If voltage is present, the back light will flash a bright red.

NOTE: Do not touch the top of the meter when using this function.

Auto Power Off 15 minutes (approximately) with disable Feature

NOTE: Auto Power function will be disable when set the range to VDC-AC.

Polarity	Automatic (no indication for positive); Minus (-) sign for negative
Measurement Rate	2 times per second, nominal
Low Battery Indication	“  ” is displayed if battery voltage drops below operating voltage
Battery	One 9 volt (NEDA 1604) battery
Fuses	mA, μ A ranges; 0.5A/1000V ceramic fast blow A range; 10A/1000V ceramic fast blow
Operating Temperature	41°F to 104°F (5°C to 40°C)
Storage Temperature	-4°F to 140°F (-20°C to 60°C)
Operating Humidity	Max 80% up to 87°F (31°C) decreasing linearly to 50% at 104°F (40°C)
Storage Humidity	<80%
Operating Altitude	7000ft. (2000meters) maximum.
Weight	0.753lb (342g) (includes holster).
Size	7.36" x 3.2" x 2.0" (187 x 81 x 50mm) (includes holster)
Safety	This meter is intended for origin of installation use and protected, against the users, by double insulation per EN61010-1 and IEC61010-1 2 nd Edition (2001) to Category IV 600V and Category III 1000V; Pollution Degree 2. The meter also meets UL 61010-1, 2 nd Edition (2004), CAN/CSA C22.2 No. 61010-1 2 nd Edition (2004), and UL 61010B-2-031, 1 st Edition (2003)



MAJOR TECH (PTY) LTD

Cnr Rover & Jaguar Roads,
Rustivia Ext 3, Elandsfontein
P.O. Box 888, Isando 1600,
South Africa

Telephone: + 27(0) 11 822-1551

Sales Fax: + 27 (0) 11 822-2806

Admin Fax: + 27 (0) 11 822-1411

National Telephone: 0861 MAJORT
(62 5678)

E-mail: sales@major-tech.com

www.major-tech.com

© 2011 , MAJOR TECH (PTY) LTD.
All rights reserved E&OE