

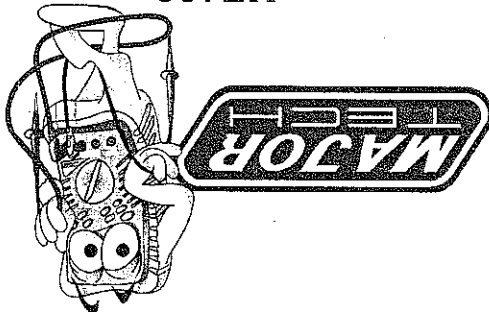

**AUTOMOTIVE MULTIMETER
USER'S MANUAL
MT188**



Contents

1	Introduction.....
2	Safety.....
6	Getting Started.....
7	Digital LCD Display.....
7	Front Panel Description.....
8	LCD Symbols.....
9	Push-button Functions.....
9	Mode Button.....
9	Manual range & Stroke 4/2.Hz,%ms,CYL Button.....
9	Data Hold /Backlight Button.....
11	Relative Button.....
12	Voltage (V).....
13	Resistance (Ω).....
14	Diode Check(▶).....
15	Capacitance(CAP).....
16	Audible Continuity (••).....
17	AC or DC Current (A).....
18	Temperature (°C/°F).....
19	Frequency (Hz).....
20	Dwell (Δ°).....
21	Duty Cycle (%).....
22	Ms - PULSE.....
24	RPM ().....
30	General Specifications.....
31	Electrical Specifications.....
34	Replacing the Battery.....
35	Battery Installation.....
35	Replacing the Fuses.....
36	Trouble Shooting.....

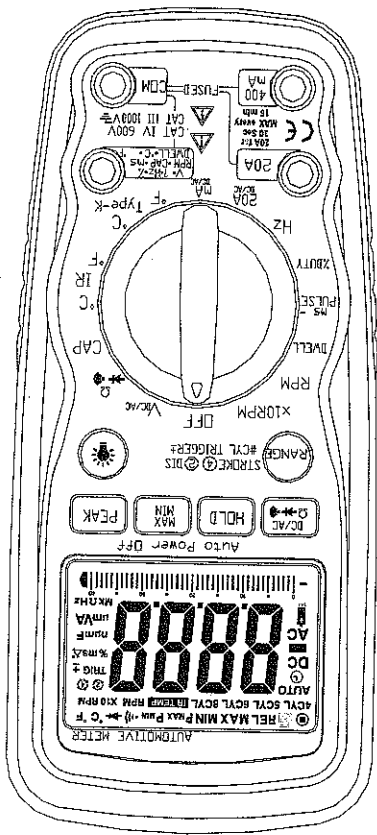

This chapter covers brief, introductory information, You will find: • Safety precautions

Safety



- Engines produce carbon monoxide which is odorous, causes slower reaction time, and can lead to serious injury. When the engine is operating, keep service areas WELL VENTILATED or attach the vehicle exhaust system to the shop exhaust removal system.



- Set the parking brake and block the wheels before testing or repairing the vehicle. It is especially important to block the wheels on front-wheel drive vehicles; the parking brake does not hold the drive wheels.

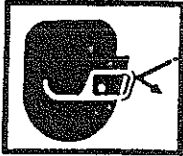

- Wear an eye shield when testing or repairing vehicles.

Exceeding the limits of this meter is dangerous. This will expose you to serious or possibly fatal injury. Carefully read and understand the cautions and the specification limits of this meter.



- Voltage between any terminal and ground must not exceed 600V DC or 600V AC.

- Use caution when measuring voltage above 25V DC or 25V AC.
- Circuit tested must be protected by a 20A fuse or circuit breaker.
- Do not use the meter if it has been damaged.
- Do not use the test leads if the insulation is damaged or if metal is exposed.

Safety Cont'd...



- Avoid electrical shock: do not touch the test leads, tips or the circuit being tested.

- Do not try a voltage measurement with the test leads in the 20A or the mA terminal.

- When testing for the presence of voltage or current, make sure the meter is functioning correctly. Take a reading of a known voltage or current before accepting a zero reading.

- Choose the proper range and function for the measurement. Do not try voltage or current measurements that may exceed the ratings marked on the Function/Range switch or terminal.

- When measuring current, connect the meter in series with the load.

- Never connect more than one set of test leads to the meter.

- Disconnect the live test lead before disconnecting the common test lead.

- The mA and the 20A terminals are protected by fuses. To avoid possible injury or damage, use only in circuits limited to 400mA or 20A for 30 seconds.

See also...

- Fuse Replacement



Safety Cont'd...

IMPORTANT

- To maintain accuracy of the meter, replace the discharged battery immediately when the battery symbol "BAT" appears on the meter display.

- Avoid measuring error from outside interference. Keep the meter away from spark plug or coil wires.
- Avoid damaging the meter when testing voltage. Disconnect the test leads from the test points before changing functions.
- Do not exceed the limits shown in the table below:

Function	Terminal	Input limit
DC/AC Volts; Ohm/Continuity /Diode,CAP,IR- TEMP. Adaptor, Type-K TEMP,HZ,%Duty, Ms Dwell, RPM	V-Ω-RPM	600VoltsAC DC
AC/DC μA/ mA	μA/ mA	400mA DC/AC
AC/DC20A	20A	*20A DC/AC

* 20 Amp measurement for 30 seconds maximum.

① Ohms can not be measured if voltage is present, ohms can be measured only in a non-powered circuit. However, the meter is protected to 600 volts.

Getting Started

This chapter will help you get started. It describes the basic functions of the Meter.

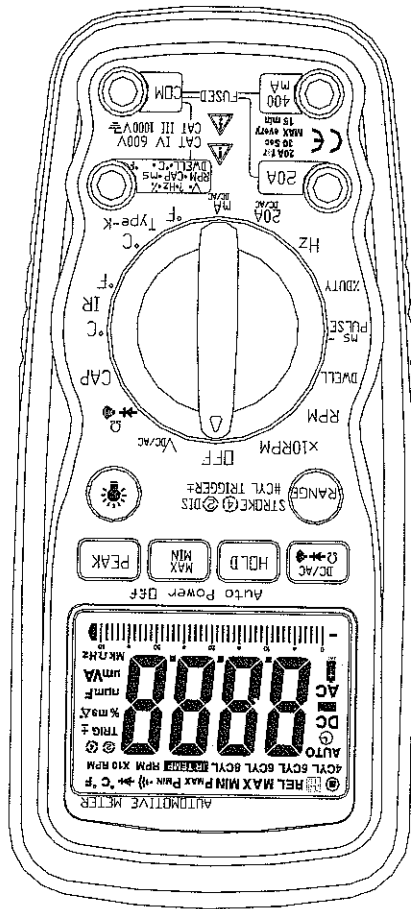

Meter Basics

1. Digital LCD display

Display features:

- 1a. Symbols to identify function
- 1b. Four character digital display

The digital display is best for stable input. The bar graph is best for rapidly changing input.

2. Function buttons

Press the button to select a function. A symbol will display to verify your choice.

3. Rotary Selector Switch

Turn this switch to select a function or turn the meter OFF.

4. Volts Terminal

The Red test lead is used to measure Amps, Volts, Ohms, TEMP, Hz, RPM, Cap, mS and Dwell.

The Black test lead is used in the Common(COM) terminal for all tests

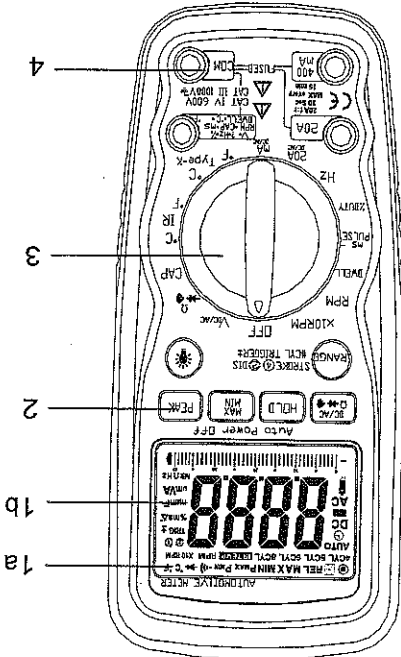

LCD DISPLAY SYMBOLS AND ANNUNCIATORS

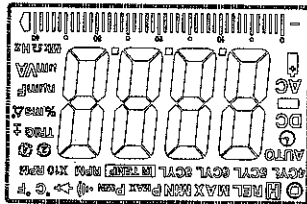

-8.8.8.8 LCD display reading



Continuity

BAT

Low Battery



Diode

DATA HOLD Data Hold

AUTO

AutoRanging

AC

Alternating Current or Voltage

DC

Direct Current or Voltage

n

nano (10^9) (capacitance)

μ

micro (10^6) (amps, cap)

m

milli (10^3) (volts, amps)

k

kilo (10^3) (ohms) F

M

mega (10^6) (ohms)

Hz

Hertz (frequency)

%

Percent (duty ratio)

$^{\circ}$ F

Degrees Fahrenheit

$^{\circ}$ C

Degrees Centigrade

IR TEMP Infrared Temperature

A Amps
 Ω Ohms
 V Volts
 Farads (capacitance)

Push-button Functions

Press the mode pushbutton to select the following functions:

DC/AC Voltage, DC/AC Current
Resistance, Diode, Continuity & Capacitance

Manual Range & Stroke 4/2(DIS), Hz, %, ms \pm , CYL Button

Press to this button to select: STROKE 4, 2DIS, Hz, %, ms \pm , CYL range & V/A Resistance

manual Range

Manual Ranging

The meter turns on in the autoranging mode.

Press the Range button to go to manual ranging.

The display icon "  " will appear. Each press of the range button will step to the next range as indicated by the units and decimal point location. Press and hold the Range button for two seconds to return to autoranging.

Data Hold

The Data Hold function allows the

meter to "freeze" a measurement for

later reference.

1. Press the DATA HOLD button to

"freeze" the reading on the indicator.

The indication of "HOLD" will appear

in the display.

2. Press the DATA HOLD button

again to return to normal operation.

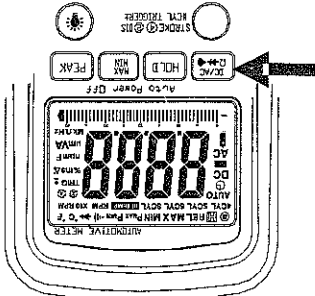
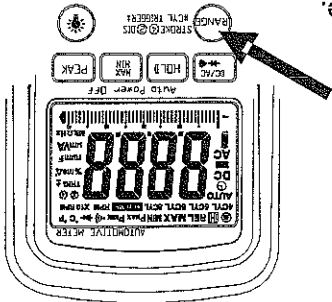
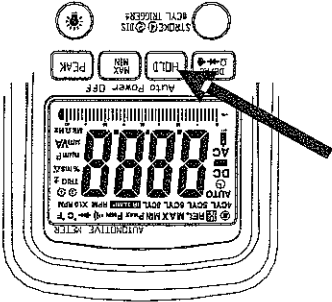

Peak Hold

The Peak Hold function captures the peak AC or DC voltage or current. The meter can capture negative or positive peaks as fast as 1 millisecond in duration.

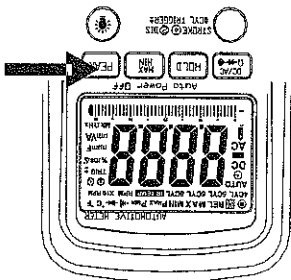

1. Turn the function switch to the A or V position.
 2. Press and Hold the **PEAK** button until "CAL" appears in the display. This procedure will zero the range selected & meter go to manual ranging .
 3. Press the **PEAK** button, **Pmax** will display.
 4. The display will update each time a higher positive peak occurs.
 5. Press the **PEAK** button again, **Pmin** will display. The display will now update and indicate the lowest negative peak.
 6. To return to normal operation, press and hold the **PEAK** button until the **Pmin** or **Pmax** indicator switches off.
- Note:** If the Function switch position is changed after a calibration the Peak Hold calibration must be repeated for the new function selected.

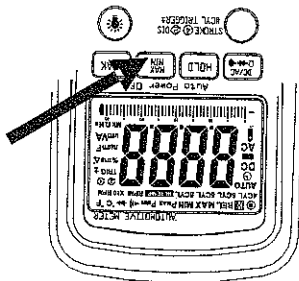

1. Press the **MAX/MIN** key to activate the **MAX/MIN** recording mode. The display icon "**MAX or MIN**" will appear. The meter will go to manual ranging & display and hold the maximum or minimum reading and will update only when a new "max or min" occurs.
 2. Press the **MAX/MIN** key and a blinking "**MAX MIN**" will appear. The meter will display the present reading, but will continue to update and store the max and min readings.
- To exit **MAX/MIN** mode press and hold the **MAX/MIN** key for 2 seconds.

Backlight Button

1. Press the **BACKLIGHT** button to turn the backlighting ON.
2. Press the **BACKLIGHT** button again to turn the backlighting OFF.

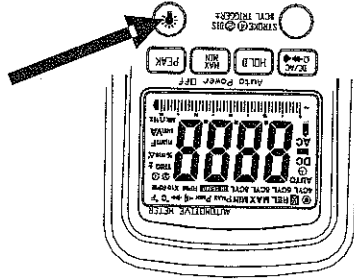

Meter Functions - Voltage (V)

- ⇒ Select the **Volts** "V" range with the rotary switch.
- ⇒ The meter will automatically select the best voltage (V) range.
- ⇒ Select DCV or ACV with the **MODE** button.

Insert:

- Black lead in **COM** terminal.
- Red lead in **V-Ω-RPM** terminal

Touch the Black probe to ground or to the negative (-) circuit

Touch the Red probe to the circuit coming from the power source

IMPORTANT: Voltage must be measuring in parallel (Red probe measuring circuit from power source).

WARNING

When measuring voltage, in the terminal marked "V", if the test lead is in an Amp (A) or Milliampere (mA) terminal, you may be injured or the meter damaged.

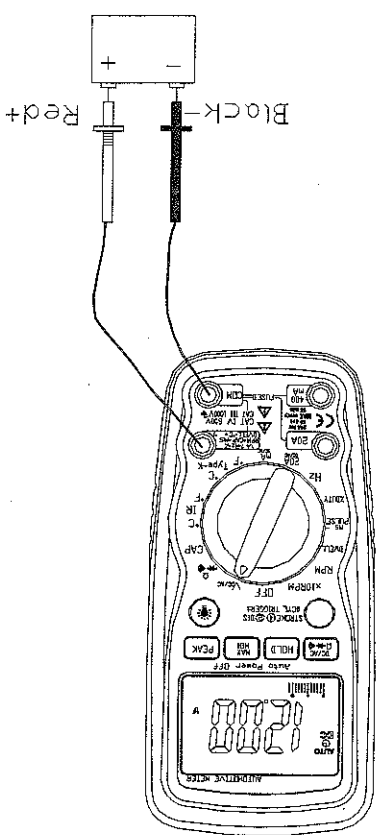

Meter Functions – Resistance (Ω)

IMPORTANT: If you are testing an application that has capacitors in the circuit, be sure to turn the power OFF on the test circuit and discharge all capacitors. Accurate measurement is not possible if external or residual voltage is present.

⇒ Select the Resistance " Ω " range with the rotary switch.

⇒ Select the Resistance " Ω " function with the Mode button. Please note, the unit defaults to resistance.

Insert:

- Black lead in COM terminal.
- Red lead in V- Ω -RPM

terminal.

Touch the test lead probes across the resistor to be tested.

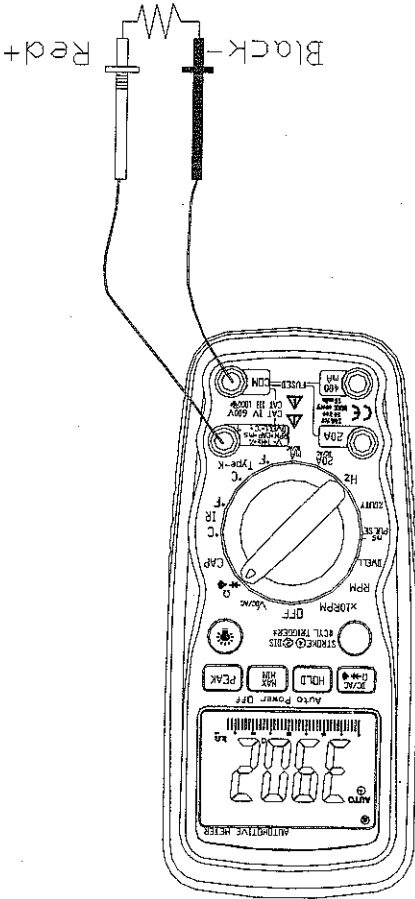

Meter Functions - Diode Check ()

IMPORTANT: Turn the power OFF to the test circuit

↔ Select the Diode Check "  " function with the rotary switch and mode button.

Insert:

Black lead in **COM** terminal.

Red lead in **V-Ω-RPM** terminal.

Touch the Black test probe to the negative (-) side of the diode.
 Touch the Red test probe to the positive (+) side of the diode. Reverse the probes: Black to the positive

(+) side and Red to the negative (-) side.

Note:

A "good" diode will read low in one direction and high in the other direction when the probes are reversed (or vice versa).
 A defective diode will have the same reading in both directions or read between 1.0 to 3.0 V, in both directions

Diode	- to +	
	+ to -	Reverse Probes
Good	.4 to .9V	OL
	1.0 to 3.0V	OL
Bad	.4 to .9V	OL
	.000V	OL

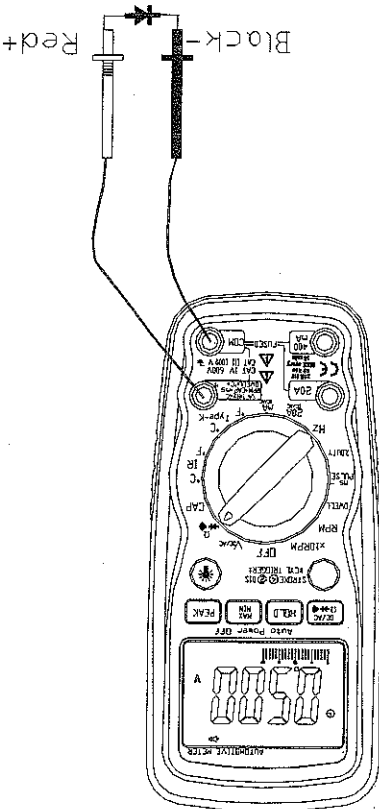

Meter Functions – Capacitance (CAP)

IMPORTANT: Turn the power OFF to

the test circuit

⇒ select the Capacitance "CAP" function with the rotary switch and

mode button

Insert:

Black lead in **COM** terminal.

Red lead in **V-Ω-RPM** terminal

CAUTION: When checking in-circuit

capacitance, be sure

that the circuit has all power

removed and all capacitors are

fully discharged.

Touch the test lead probes across the

capacitance circuit to be tested.

Read the measured value from the

LCD display.

Note:

1. The bar graph is disabled in capacitance measurement mode.

However, since the measurement time of 4mF and 40mF

modes is quite long (3.75s and 7.5s respectively,

to be precise.)

the bar graph is used to display

the time rest to accomplish the measurement.

2. In order to obtain an accurate reading,

a capacitor must be discharged before measurement begins. The meter has a

built-in discharge mode to automatically discharge the capacitor. In discharge

mode, the LCD displays "DIS.C"

3. Discharging through the chip is quite slow. We recommend the user to

discharge the capacitor with some other apparatus.

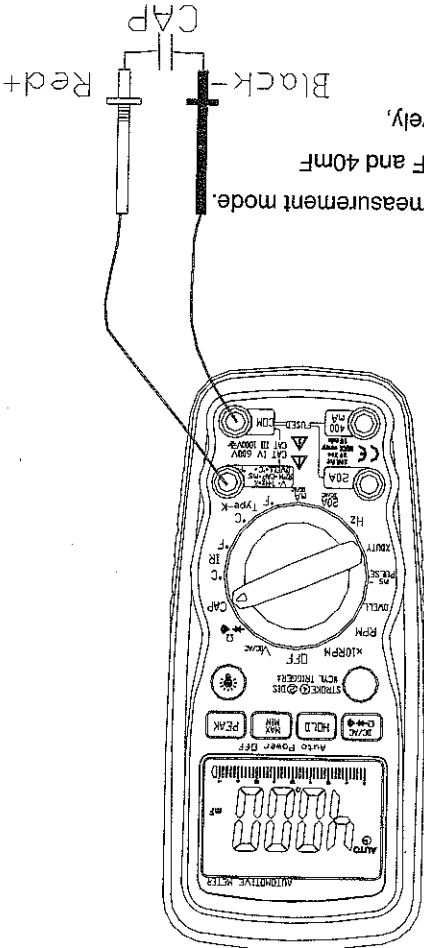

Meter Functions - Audible Continuity (•••••)

IMPORTANT: Turn the power OFF on the test circuit

⇒ Select the Audible Continuity “•••••” function with the rotary switch and mode button.

Insert:

- Black lead in COM terminal.
- Red lead in V-Ω-RPM terminal.

Connect one test probe to each end of the circuit to be tested.

- Circuit complete, the meter will beep continuously.

- Circuit open, there is no beep and the display shows to OL (over limit).

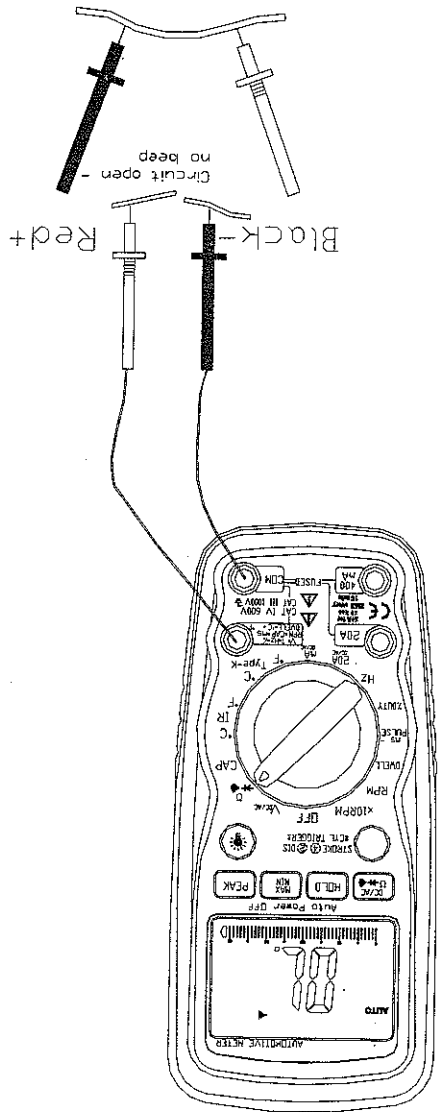

Meter Functions - AC or DC Current (A)

IMPORTANT: All current measured flows through the meter.

It is important that you do not:

- Measure current greater than 600 Volts AC or DC, with respect to ground.
- Do Not Exceed 30 seconds when measuring continuous current between 1A-20A.
- Allow five minutes for cool down before continuing.

⇒ Select the "20A" or "mA" range with the rotary switch.

⇒ Press the **Mode** button to select AC or DC.

Insert:

- Black lead in **COM** terminal.
- Red lead in the **20A** or **mA** terminal (select 20A if you are unsure of the current draw).

IMPORTANT: Turn **OFF** all power to the circuit or disconnect the circuit from the power source.

Connect:

- The Red probe to the side of the circuit closest to the power source.
- The Black probe to the side of the circuit to ground.

- Turn the power **ON** and test.

Note: Current must always be measured with the meter test probes connected in series, as described.

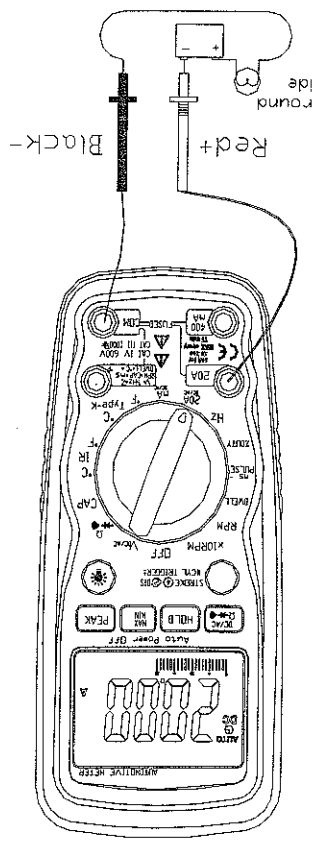

Meter Functions - Temperature (C/°F)

IMPORTANT: To avoid heat damage to the meter, keep it away from sources of very high temperature. The life of the Temperature Probe is also reduced when subjected to very high temperatures. Probe operating range is -58° to 482° F.

⇒ Select the Temperature "C or °F" function with the rotary switch.

⇒ Insert the temperature probe connector into the K-type thermocouple adapter. Insert the adapter into the front of the meter as shown. Touch the end of the temperature sensor to the area or surface of the object to be measured.

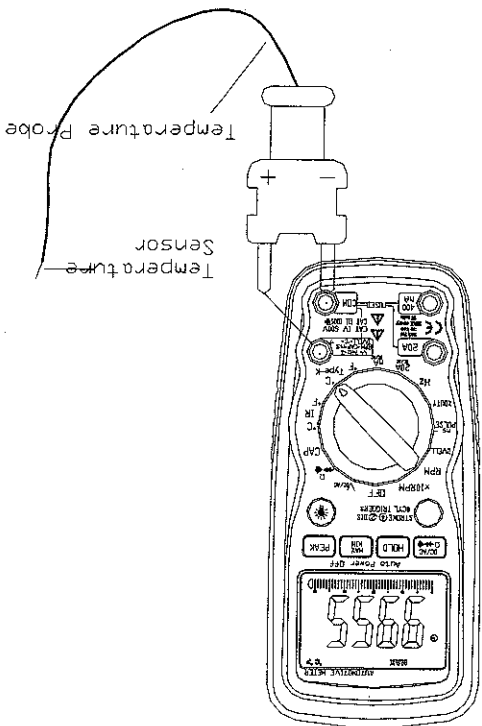

Meter Functions – Frequency(Hz)

⇒ Select the “Hz” Frequency function with the rotary switch.

Insert:

- Black lead in **COM** terminal.

- Red lead in **V- Ω -RPM** terminal.

Connect the Black test probe

to ground.

Connect the Red test probe to

the “signal out” wire of the

sensor to be tested.

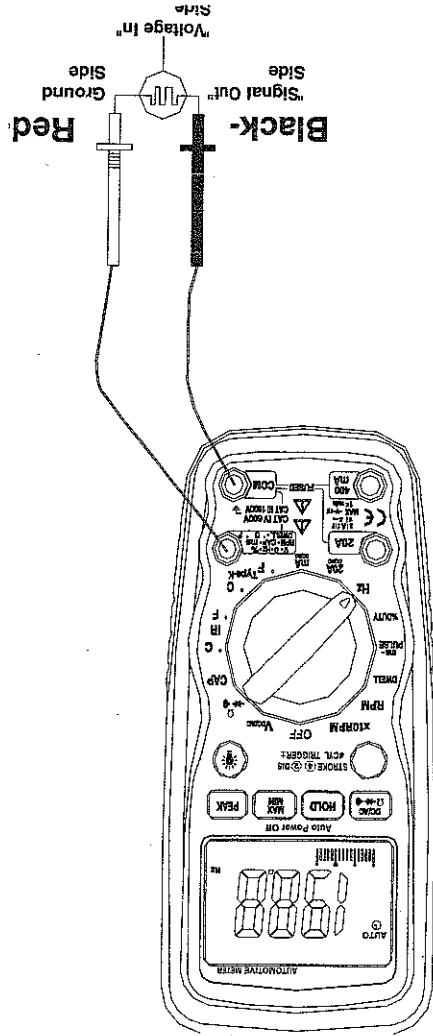

Meter Functions-Dwell ()

→ Select the "DWEll" function with the rotary switch.

Insert:

- Black lead in COM terminal.
- Red lead in V- Ω -RPM terminal.

terminal.

Connect the Black test probe to

ground.

Connect the Red test probe to the

breaker points (see illustration).

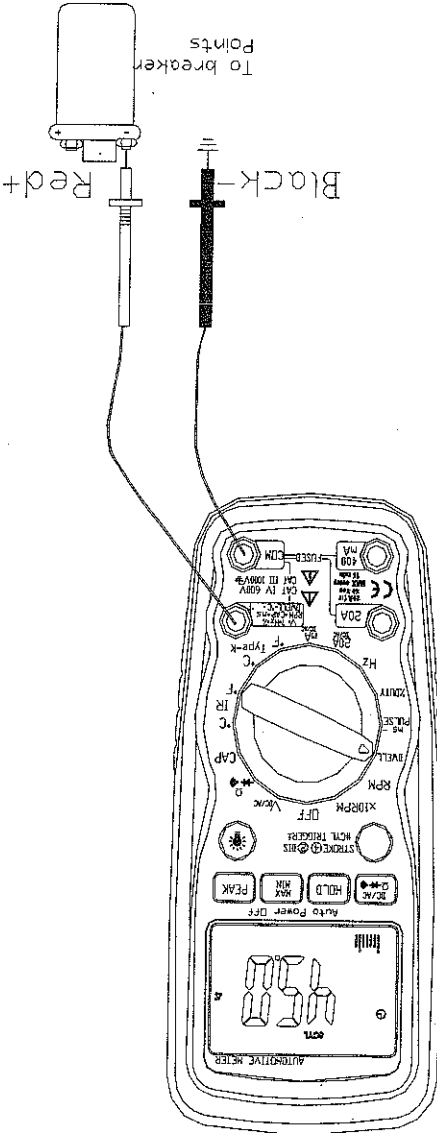

Meter Functions-Duty Cycle (%)

⇒ Select the “% Duty” Cycle function with the rotary switch.

Insert:

- Black lead in **COM** terminal.
- Red lead in **V-Ω-RPM** terminal.

Connect the Black test probe to ground.

Connect the Red test probe to the signal wire circuit.

The illustration for a mixture control solenoid is shown with the metering rod in the closed position. The meter will display the percentage of time the plunger is in the closed position. (low duty cycle) during one duty cycle.

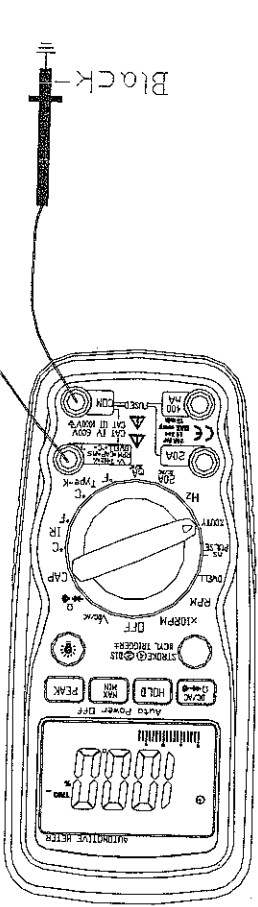

Meter Functions- ms-PULSE (Pulse Width) & ms-PERIOD (Period)

Pulse Width is the length of time an actuator is energized. For example, fuel injectors are activated by an electronic pulse from the Engine Control Module (ECM).

This pulse generates a magnetic field that pulls the injectors nozzle valve open.

The pulse ends and the injector nozzle is closed.

This open to close time is the Pulse Width and is measured in milliseconds (ms).

The most common automotive application for measuring pulse width is on fuel injectors.

You can also measure the pulse width of the fuel mixture control solenoid and the idle air control motor.

This exercise shows how to measure Pulse Width on Port Fuel injectors.

(continued on next page)

To measure pulse width (ms):

⇒ Select the "ms-Pulse" function with the rotary switch.

⇒ Press the \pm TRIG button for 2 seconds until the negative (-) trigger slope is displayed on the upper left side of the display.

NOTE : The applied time for most fuel injectors is displayed on the negative (-) slope.

Insert:

Black lead in COM jack.

Red lead in V- Ω -RPM jack.

Connect:

Jumper wires between the fuel injector and the harness connector.

Black test probe to a good ground at the fuel injector or the negative (-) vehicle battery post.

Red test probe to the fuel injector solenoid driver input on the jumper cable.

Start the engine. A pulse width in milliseconds should be read.

Note: Initially, the unit will read "OL", then readings will descend and stabilize to the actual pulse width. If "OL" remains, re-check your connections.

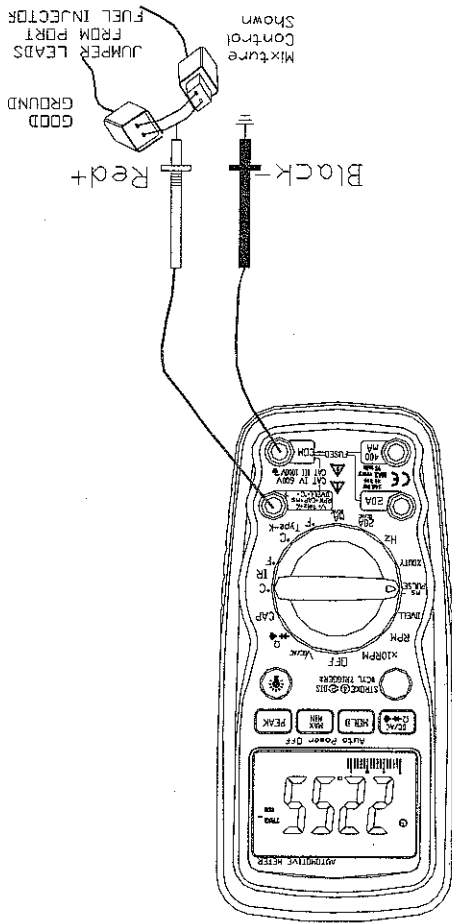

Meter Functions-RPM/X 10RPM

⇒ Select the **RPM** range with the rotary switch.

OR

⇒ Select the **X 10RPM** range with the rotary switch (1,000 to 12,000 RPM). Multiply the displayed reading by ten to get actual RPM.

⇒ Press **STROKE** (4) / **DIS** button to select through RPM (4) for 4-stroke, RPM (2) for 2-stroke and DIS ignitions.

Insert the inductive pickup connecting terminal into the meter.

- Black lead in **COM** terminal.
- Red lead in **V-Ω-RPM** terminal.

Connect the inductive pickup to a spark plug wire. If no reading is received, unhook the clamp, turn it over and connect again.

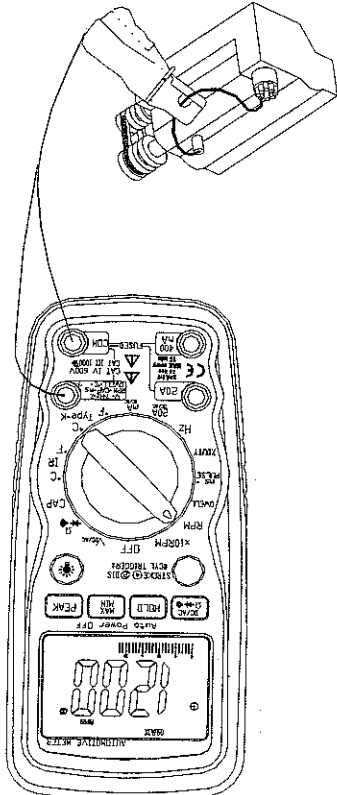

- Note:**
- Position the inductive pick-up as far away from the distributor and the exhaust manifold as possible.
 - Position the inductive pick-up to within six inches of the spark plug or move it to another plug wire if no reading or an erratic reading is received.
- RPM 4 :** For RPM of 4-stroke engines which have 1 ignition on every 4 engine strokes
- RPM 2 :** For RPM of DIS (Distributorless Ignition System) & 2-stroke engines which Have 1 ignition on every 2 engine strokes

PLEASE NOTE- THE RPM PICK-UP HAS AN ADJUSTABLE SENSITIVITY SWITCH THAT CAN ALSO BE USED TO CORRECT AN UNSTABLE READING

Meter Functions - Non-contact Infrared Temperature (C/ $^{\circ}$ F) measurements

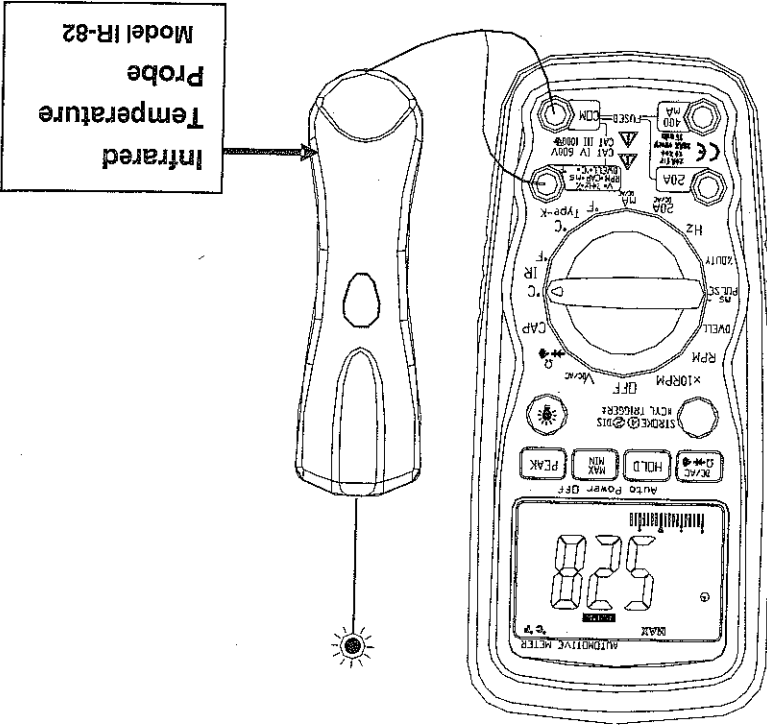

Infrared Temperature Probe Introduction (Model IR-82)

The Infrared Temperature Probe is a noncontact temperature measurement accessory for use with a test instrument capable of measuring DC volts in the millivolt range (200mV/400mV/600mV/2V/4V/6V range) such as a digital

multimeter (DMM) or the automotive meter (AT-9955)'s Infrared Temperature (C/°F) ranges. The probe has a temperature range of -30°C to 550°C (-22°F to 1022°F), with a basic accuracy of 2% of reading, and an output of 1 mV dc per °C or °F.

Temperature is measured by pointing the probe at the surface to be measured, and reading the temperature on the test instrument display.

Compatibility

The probe is compatible with all DC millivolt measuring instruments or the automotive meter's (AT-9955) Infrared Temperature (C/°F) ranges measuring instruments that have a minimum of 1 MΩ input impedance and accept safety shrouded, standard diameter 0.16 in. (4 mm) banana plugs

Field of View

The meter's field of view is 8:1, meaning that if the meter is 8 inches from the target, the diameter of the object under test must be at least 1 inch. Other distances are shown below in the field of view diagram. Refer to the chart printed on the meter for more information.

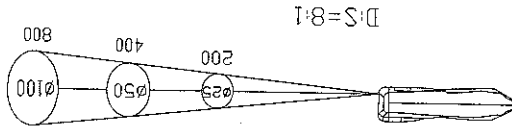

Distance(D) to Spot Size(S)

- To take a measurement, perform the following steps:
1. Plug the red connector into the V mVdc input jack and the black connector into the common or ground input jack on the test instrument.
 2. Select Infrared Temperature ($^{\circ}\text{C}/^{\circ}\text{F}$) or mV dc range on the test instrument.
 3. Press the probe button laser, the Infrared Temperature Probe ON
 4. Point the tip of the probe as close as possible to the object being measured without touching the object.
 5. Read the test instrument display.

Operation

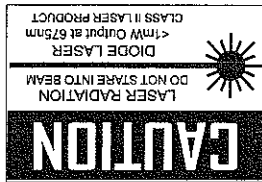

- Use extreme caution when the laser beam is turned on.
- Do not let the beam enter your eye, another person's eye or the eye of an animal.
- Be careful not to let the beam on a reflective surface strike your eye.

SAFETY

Field of View
 Make sure that the target is larger than the unit's spot size. The smaller the target, the closer you should be to it. When accuracy is critical, make sure the target is at least twice as large as the spot size.

- If the test instrument displays an overload condition, switch the DMM range from mV dc to V dc. Increasing the range to V dc moves the decimal position three places to the left (500F displays as 0.500V).

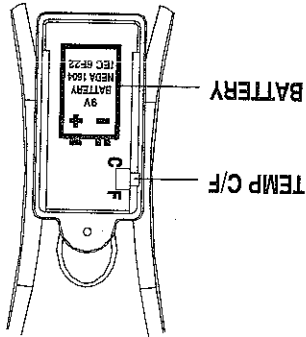

- to the desired position.
- by removing the battery from the battery compartment and moving the internal °C/°F switch
 - The temperature scale can be changed to °C or °F
 - the DMM display will show 0°C or 0°F or 0mV.
 - Release the probe button laser and the Infrared Temperature Probe OFF
- Additional considerations are:**

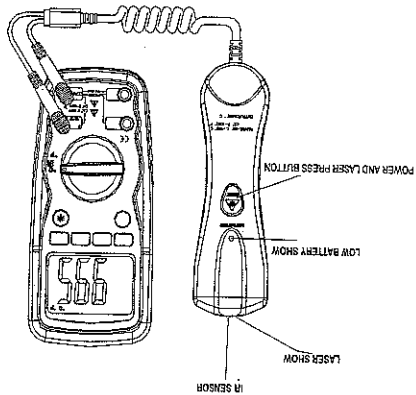

Range	-30 to 550°C/-22 to 1022°F
Output	1mV=1°C or 1°F
Accuracy	± 2% of reading or ± 4°F (2°C) whichever is greater. Note: Accuracy is specified for the following ambient temperature range: 64 to 82°F (18 to 28°C)
Emissivity	0.95 fixed value
Field of View	D/S = Approx. 8:1 ratio (D = distance, S = spot) (Has 90% encircled energy at the focal point)
Laser power	Less than 1mW
Spectral response	6 to 14 μm (wavelength)

Infrared Thermometer Specifications

Response rate	0.5 second approx.
Operating Temperature	32°F to 122°F (0°C to 50°C)
Operating Humidity	Max. 80% RH.
Power Supply	9V battery
Weight	182g
Size	164 X 50 X 40mm

General Specifications

Note: Measurement considerations

Holding the meter by its handle, point the IR Sensor toward the object whose temperature is to be measured. The meter automatically compensates for temperature deviations from ambient temperature. Keep in mind that it will take up to 30 minutes to adjust to wide ambient temperatures are to be measured followed by high temperature measurements, some time (several minutes) is required after the low (and before the high) temperature measurements are made.

This is a result of the cooling process which must take place for the IR sensor.

BATTERY REPLACEMENT

- ① As battery power is not sufficient, LED show will " ON " replacement with one new battery type 9V is required.

- ② Open battery cover, then take out the battery from instrument and replace with a new 9-Volt battery and place the battery cover back.

General Specifications

General Specifications

The instrument complies with: IEC 1010-1 EN61010-1.

Insulation: Class2, Double insulation.

Overvoltage category: CATIII1000V/CATIV600V.

Display: 4000 counts LCD display with function indication.

Polarity: Automatic, (-) negative polarity indication.

Overrange: "OL" mark indication.

Low battery indication: The "BAT" is displayed when the battery voltage drops below the operating level.

Measurement rate: 2 times per second, nominal.

Auto power off: Meter automatically shuts down after approx. 30 minutes of inactivity.

Operating environment: 0 °C to 50 °C (32 °F to 122 °F)

at > 70 % relative humidity.

Storage temperature: -20 °C to 60 °C (-4 °F to 140 °F) at > 80 %

relative humidity.

For inside use, max height: 2000m

Pollution degree: 2

Power: One 9V battery, NEDA 1604, IEC 6F22.

Dimensions: 182 (H) x 82 (W) x 55 (D) mm

Weight: Approx.: 375g.

Electrical Specifications

Electrical Specifications

*Accuracy is given as ± (% of reading)+[number of least significant digits] at 18°C to 28°C (65° F to 83° F), with relative humidity up to 70%.

RPM (Tach)

Range	Resolution	Accuracy
RPM 4	600-4000 RPM	±2% of rdg ± 4 dgt
	1000-12000 RPM (X10 RPM)	
RPM 2/DIS	300-4000 RPM	±2% of rdg ± 4 dgt
	1000-6000 RPM (X10 RPM)	
RPM 1	1 RPM	±2% of rdg ± 4 dgt
	10 RPM	

Effect Reading: >600 RPM

DEWILL ANGLE

Cylinder	Range	Resolution	Accuracy
4CYL	0-90.0°	0.1°	±2.0% of rdg ± 4 dgt
5CYL	0-72.0°		
6CYL	0-60.0°		
8CYL	0-45.0°		

DC Voltage

Range	Resolution	Accuracy
400.0mV	0.1mV	±0.5% of rdg ± 3 dgt
4.000V	1mV	±1.5% of rdg ± 2 dgt
40.00V	10mV	
400.0V	100mV	
600V	1V	±1.8% of rdg ± 2 dgt

Input Impedance: 10MΩ

Range	Resolution	Accuracy
400.0Ω	0.1Ω	±1.2% of rdg ± 4 dgts
4.000KΩ	1Ω	±1.0% of rdg ± 2 dgts
40.00KΩ	10Ω	±1.2% of rdg ± 2 dgts
400.0KΩ	100Ω	

Resistance

Overload Protection: 0.5A / 250V and 20A / 250V Fuse.
 Frequency Range: 50 to 60 Hz
 Maximum Input: 400mA dc or 400mA ac rms on uA / mA ranges,
 20A dc or ac rms on 20A range.

Range	Resolution	Accuracy
40.00mA	10uA	±1.8% of rdg ± 5 dgts
400.0mA	100uA	
20A	10mA	±3.0% of rdg ± 7 dgts

AC Current

Overload Protection: 0.5A / 250V and 20A / 250V Fuse.
 Maximum Input: 400mA dc or 400mA ac rms on uA / mA
 ranges, 20A dc or ac rms on 20A range.

Range	Resolution	Accuracy
40.00mA	10uA	±1.5% of rdg ± 3 dgts
400.0mA	100uA	
20A	10mA	±2.5% of rdg ± 5 dgts

DC Current

Input Impedance: 10MΩ
 Frequency Range: 50 to 60Hz

Range	Resolution	Accuracy
400.0mV	0.1mV	±1.5% of rdg ± 5 dgts
4.000V	1mV	±1.0% of rdg ± 3 dgts
40.00V	10mV	±1.5% of rdg ± 3 dgts
400.0V	100mV	
600V	1V	±2.0% of rdg ± 4 dgts

AC Voltage

Range	Resolution	Accuracy
1.0~20.0ms	0.1ms	$\pm 2\%$ of rdg ± 20 dgts

Pulse Width

Sensitivity: $> 5V$ RMS
 Frequency width: 5Hz – 100kHz
 Pulse width: $< 100\mu s$, $< 100ms$;

Range	Resolution	Accuracy
0.5%~99.0 %	0.1%	$\pm 2\%$ of rdg ± 5 dgts

Duty Cycle

Range	Resolution	Sensitivity	Accuracy
4.00kHz	1Hz	$> 5V$ RMS	$\pm 1.5\%$ of rdg ± 3 dgts
40.00kHz	10Hz		
400.0kHz	100Hz		
4.00MHz	1000Hz		
40.00MHz	1kHz	$> 15V$ RMS	$\pm 2.0\%$ of rdg ± 4 dgts

Frequency

Range	Resolution	Accuracy
4.00nF	1pF	$\pm 5.0\%$ of rdg ± 50 dgts
40.00nF	10pF	$\pm 5.0\%$ of rdg ± 7 dgts
400.0nF	0.1nF	$\pm 3.0\%$ of rdg ± 5 dgts
4.000uF	1nF	
40.00uF	10nF	
400.0uF	0.1uF	
4.00mF	0.001mF	$\pm 10\%$ of rdg ± 10 dgts
40.00mF	10.00mF	

Capacitance

4.000M Ω	1k Ω	$\pm 2.0\%$ of rdg ± 3 dgts
40.00M Ω	10k Ω	

WARNING: To avoid electric shock, do not operate your meter until the battery door is in place and fastened securely.

3. Dispose of the old battery properly.
- Installation section of this manual.
2. Follow instructions for installing battery. See the Battery LCD display. The battery should be replaced.
1. When the batteries become exhausted or drop below the operating voltage, "BAT" will appear in the right-hand side of the

WARNING: To avoid electric shock, disconnect the test leads from any source of voltage before removing the battery door.

REPLACING THE BATTERY

Maintenance

Audible continuity
Audible threshold: Less than 35Ω Test current: $<1\text{mA}$ dc typical

Open circuit voltage: 3.0V dc typical

Test current	Resolution	Accuracy
1.0mA typical	1 mV	$\pm 5\%$ of rdg ± 15 dgts

Diode Test

Sensor: Type K Thermocouple

Range	Resolution	Accuracy
$-30^{\circ}\text{C} \sim 1000^{\circ}\text{C}$	1°C	$\pm 3\%$ of rdg $\pm 5^{\circ}\text{C}/8^{\circ}\text{F}$
$-22^{\circ}\text{F} \sim 1832^{\circ}\text{F}$	1°F	(Meter only, probe accuracy not included)

Type-K Temperature

BATTERY INSTALLATION

WARNING: To avoid electric shock, disconnect the test leads from any source of voltage before removing the battery door.

1. Disconnect the test leads from the meter.
2. Open the battery door by loosening the screw using a Phillips head screwdriver.
3. Insert the battery into battery holder, observing the correct polarity.
4. Put the battery door back in place. Secure with the two screws.

WARNING: To avoid electric shock, do not operate the meter until the battery door is in place and fastened securely.

NOTE: If your meter does not work properly, check the fuses and battery to make sure that they are still good and that they are properly inserted.

REPLACING THE FUSES

WARNING: To avoid electric shock, disconnect the test leads from any source of voltage before removing the rear cover (fuse door).

1. Disconnect the test leads from the meter and any item under test.

2. Open the fuse door by loosening the screws on the rear cover using a Phillips head screwdriver.

3. Remove the old fuse from its holder by gently pulling it out.

3. Install the new fuse into the holder.

4. Always use a fuse of the proper size and value (0.5A/250V - ϕ 5 x 20 , fast blow for the 400mA range, 20A/250V - ϕ 6.3 x 32 fast blow for the 20A range).

5. Put the fuse door back in place. Insert the screw and tighten it securely.

- "Hold" feature is still toggled ON.
- 4. Meter readings do not change.**
- Open circuit in a test lead (frayed or broken wire).
 - "Blown" fuse.
 - Low battery.
 - Printed circuit board damaged from handling with hands.
- 3. Meter reading is erratic.**
- continuity with another meter.
- Disassemble the meter back cover as per the fuse replacement instructions on page 36 and test the fuses for
- 2. Ampere reading is erratic or there is no reading at all.**
- Check for a minimum battery voltage of 8.0 volts.
 - Check the battery contacts for a tight fit.
- 1. Meter will not turn ON.**

Trouble Shooting

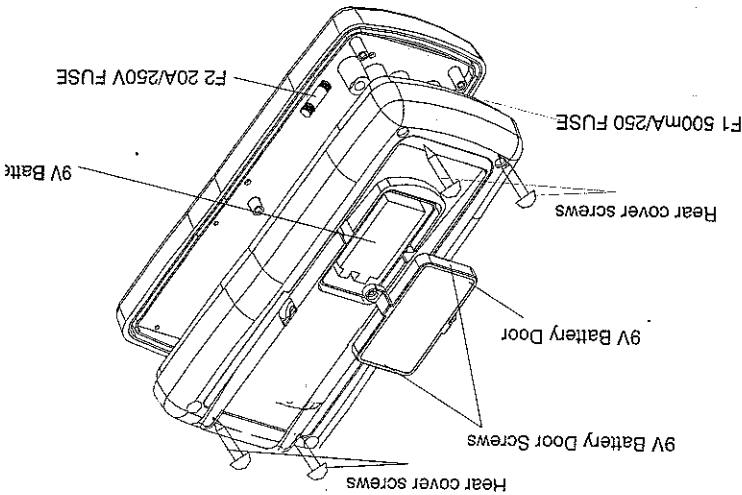

WARNING: To avoid electric shock, do not operate your meter until the fuse door is in place and fastened securely.