

## Schematic: SAMA5D4-XULT

SHEET	SHEET NAME
01	Title & Revision History
02	Block Diagram
03	PIO Muxing
04	Power Supply
05	SAMA5D44- Power
06	SAMA5D44- DDR2
07	SAMA5D44- PIOA & PIOB
08	SAMA5D44- PIOC & FLASH
09	SAMA5D44- SYS & PIOD & PIOE
10	JTAG & USB & DEBUG & LCD
11	HDMI
12	Ethernet_ETH0_10/100M
13	HSMCI
14	EDBG
15	Expansion & XPRO Connectors

## Revision History

DATE	REVISION	DESCRIPTION
29 Aug 2014	SAMA5D4 Xplained RevA-140829	First Release Version
29 Sep 2014	SAMA5D4-XULT RevA-140929	Second Release Version,First Revision.
30 Sep 2014	SAMA5D4-XULT RevA-140930	Second Release Version,Second Revision.

## Revision History

### 1. SAMA5D4 Xplained RevA-140829

1)First release version, the version of PCB is <SAMA5D4 Xplained RevA-140826.brd>, have made 20 PCS prototypes.

### 2. SAMA5D4-XULT RevA-140929

1)Replaced all those shunted jumpers(JP2 to JP6) with internally shunted footprints, and re-route the PCB.

2)Replaced U15/AT24MAC402-SSHM-T with AT24MAC402-MAHM-T(from SOIC-8 to UDFN-8).

3)Removed C14, C16, C31, C34, C148.

4)Swaped the MCI0 and MCI1 SD card connector, removed R213=R220=R223=R228=22R, removed R351=R353=R381=R392=68K.

5)Changed name of the board:SAMA5D4-XULT.

6)Pin3 of J6 and Pin5 of J14 with a 100R (signal NRST\_3V3, added R213=R220=100R).



7)D11 Pin1 connected to VCC\_5V vs VCC\_3V.

8)Changed R53,R73,R80,R96,R149,R208,R212,R277,R278 from 22R to 39R.

### 3. SAMA5D4-XULT RevA-140930

1)Renumbered all components.

2)Placed R374 and R367 close to U6(SAMA5D44, Pin H5, PA24).

		RevA	XinJQ	30-Sep-14	XXX	XX-XX-XX
		INIT EDIT	XinJQ	29-Aug-14	XXX	XX-XX-XX
SAMA5D4-XULT		SCALE	1/1	REV.	SHEET	
Title & Revision History				A	1/15	

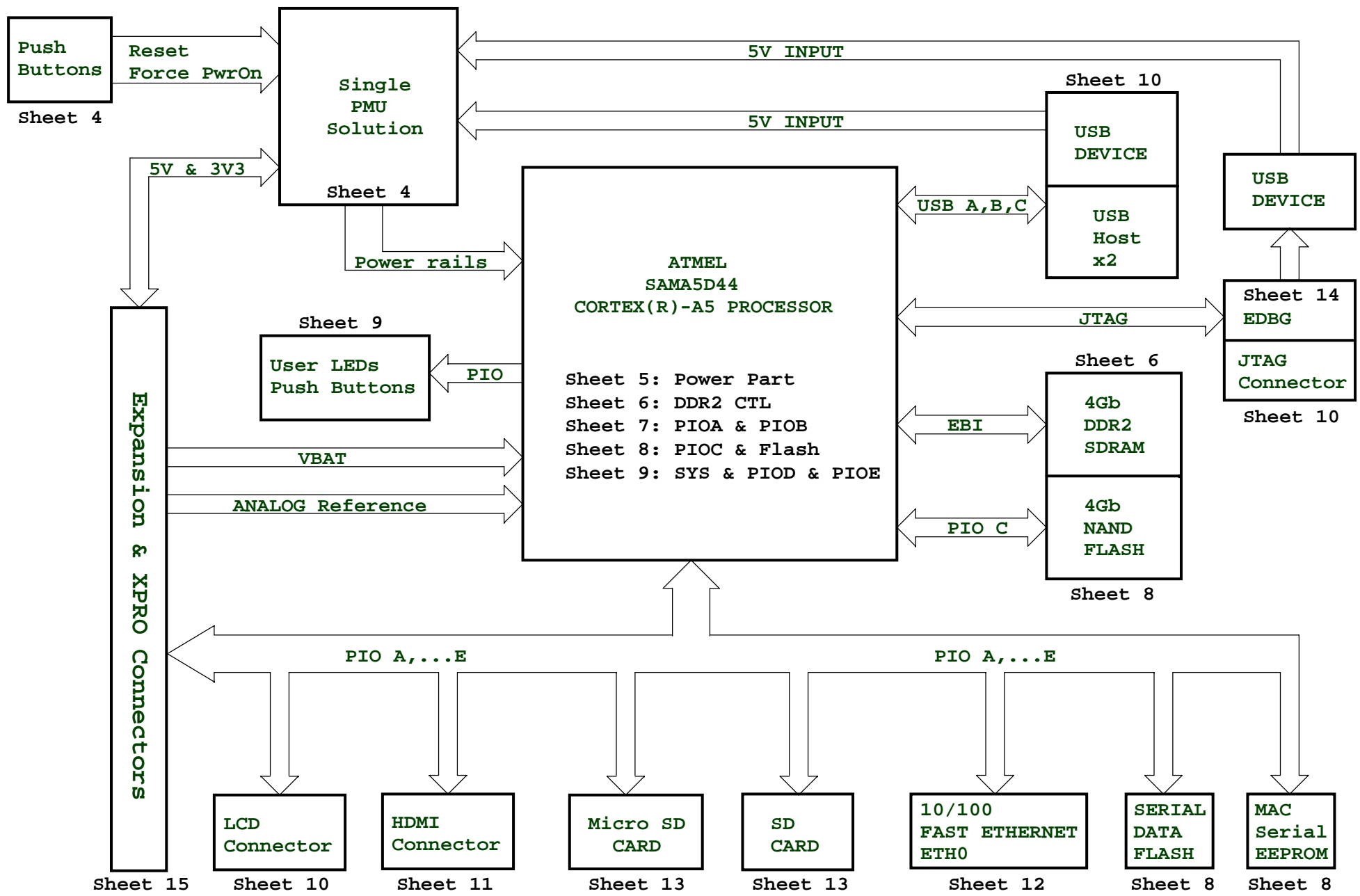

<b>Atmel</b>							
RevA	XinJQ	30-Sep-14	XXX	XX-XX-XX			
INIT EDIT	XinJQ	29-Aug-14	XXX	XX-XX-XX			
REV	MODIF.	DES.	DATE	VER.	DATE		
SAMA5D4-XULT	SCALE	1/1		REV.	A	SHEET	2/15
Block Diagram							

# PIO Muxing & Jumper setting

LCD	
ID_SYS	1
GND	2
LCDDAT0	3
LCDDAT1	4
LCDDAT2	5
LCDDAT3	6
GND	7
LCDDAT4	8
LCDDAT5	9
LCDDAT6	10
LCDDAT7	11
GND	12
LCDDAT8	13
LCDDAT9	14
LCDDAT10	15
LCDDAT11	16
GND	17
LCDDAT12	18
LCDDAT13	19
LCDDAT14	20
LCDDAT15	21
GND	22
LCDDAT16	23
LCDDAT17	24
LCDDAT18	25
LCDDAT19	26
GND	27
LCDDAT20	28
LCDDAT21	29
LCDDAT22	30
LCDDAT23	31
GND	32
LCDPCK	33
LCDVSYNC	34
LCDHSYNC	35
LCDDEN	36
SPI1_SPCK/AD3_YM	37
SPI1_MOSI/AD2_YP	38
SPI1_MISO/AD1_XM	39
SPI1_NPCS2/AD0_XP	40
LCDDISP	41
TWD0	42
TWCK0	43
IRQ1	44
IRQ2	45
LCDPWM	46
Reset	47
VCC	48
VCC	49
GND	50

PIOA	USAGE	PIOA	USAGE	PIOB	USAGE	PIOB	USAGE	PIOC	USAGE	PIOC	USAGE
PA0	LCDDAT0/JTAG_TMS	PA16	LCDDAT16/NTRST	PB0	G0_TXCK	PB16	G0_MDC	PC0	SPI0_MISO/PWMH2/ISI_D8	PC16	NAND_RDY
PA1	LCDDAT1	PA17	LCDDAT17	PB1	SCK2/ISI_PCK	PB17	G0_MDIO	PC1	SPI0_MOSI/PWML2/ISI_D9	PC17	NAND_ALE
PA2	LCDDAT2	PA18	LCDDAT18	PB2	G0_TXEN	PB18	SPI1_MISO	PC2	SPI0_SPCK/PWMH3/ISI_D10	PC18	NAND_CLE
PA3	LCDDAT3	PA19	LCDDAT19	PB3	CTS2/ISI_VSYNC	PB19	SPI1_MOSI	PC3	SPI0_NPCS0/PWML3/ISI_D11	PC19	ISI_D0/TK1
PA4	LCDDAT4	PA20	LCDDAT20	PB4	RXD2/ISI_HSYNC	PB20	SPI1_SPCK	PC4	MCIO_CK/PCK1	PC20	ISI_D1/TF1
PA5	LCDDAT5	PA21	LCDDAT21	PB5	TXD2/PCK2	PB21	SPI1_NPCS0	PC5	MCIO_CDA/NAND_D0	PC21	ISI_D2/TD1
PA6	LCDDAT6	PA22	LCDDAT22	PB6	G0_RXDV	PB22	SPI1_NPCS1	PC6	MCIO_DA0/NAND_D1	PC22	ISI_D3/RF1
PA7	LCDDAT7	PA23	LCDDAT23	PB7	G0_RXER	PB23	SPI1_NPCS2	PC7	MCIO_DA1/NAND_D2	PC23	ISI_D4/RD1
PA8	LCDDAT8/JTAG_TCK	PA24	LCDPWM/HDMI_MCK	PB8	G0_RX0	PB24	JTAG_TDI	PC8	MCIO_DA2/NAND_D3	PC24	ISI_D5/RK1/PCK1
PA9	LCDDAT9	PA25	LCDDISP/HDMI_INT	PB9	G0_RX1	PB25	JTAG_TDO	PC9	MCIO_DA3/NAND_D4	PC25	ISI_D6/TWD3/URXD1
PA10	LCDDAT10	PA26	LCDVSYNC	PB10	PCK2/PWML1	PB26	PCK0/RK0/PWMH0	PC10	NAND_D5	PC26	ISI_D7/TWCK3/UTXD1
PA11	LCDDAT11	PA27	LCDHSYNC	PB11	RTS2/PWMH1	PB27	SPI1_NPCS3/HDMI_TK0/PWML0	PC11	NAND_D6	PC27	AD0_XP/PWML0
PA12	LCDDAT12	PA28	LCDPCK	PB12	G0_TX0	PB28	SPI2_NPCS3/HDMI_TD0/PWMH1	PC12	NAND_D7	PC28	AD1_XM/PWML1
PA13	LCDDAT13	PA29	LCDDEN	PB13	G0_TX1	PB29	TWD2/RD0/PWML1	PC13	NAND_RE	PC29	AD2_YP/PWMF10
PA14	LCDDAT14	PA30	TWD0	PB14	SPI2_NPCS1/PWMH0	PB30	TWCK2/RF0	PC14	NWE/NAND_WE	PC30	AD3_YM/PWMH0
PA15	LCDDAT15	PA31	TWCK0	PB15	SPI2_NPCS2/PWML0/HDMI_RST	PB31	HDMI_TF0	PC15	NAND_NCS3	PC31	AD4/PWMH1

PIOD	USAGE	PIOD	USAGE	PIOE	USAGE	PIOE	USAGE
		PD16	RXD1	PE0	USB_OVCUR/CTS4	PE16	DBGU_RXD3
		PD17	TXD1/SPI2_NPCS0	PE1	G0_IRQ	PE17	DBGU_TXD3
		PD18	SENSE0	PE2	MCIO_CD	PE18	TIOA5/MCI1_CK
		PD19	SENSE1	PE3	MCI1_CD	PE19	TIOB5/MCI1_CDA
		PD20	SENSE2	PE4	MCI1_PWR	PE20	TCLK5/MCI1_DA0
		PD21	SENSE3	PE5	DBGU_CTS3	PE21	TIOA4/MCI1_DA1
		PD22	SENSE4	PE6	TIOA3	PE22	TIOB4/MCI1_DA2
		PD23	SENSE5	PE7	TIOB3	PE23	TCLK4/MCI1_DA3
PD8	PCK0	PD24	SENSE6	PE8	PB_USER/TCLK3	PE24	DBGU_RTS3
PD9	FIQ	PD25	SENSE7	PE9	LCD_IRQ1	PE25	PMIC_IRQ/SCK4
PD10	CTS0	PD26	SENSE8	PE10	LCD_IRQ2	PE26	RXD4
PD11	RTS0/SPI2_MISO	PD27	SENSE9	PE11	USBB_EN5V	PE27	TXD4
PD12	RXD0	PD28	SCK0	PE12	TIOA1/PWMH2	PE28	RTS4
PD13	TXD0/SPI2_MOSI	PD29	SCK1	PE13	TIOB1/PWML2	PE29	URXD0/TWD1
PD14	CTS1	PD30	LED_POWER	PE14	USBC_EN5V	PE30	UTXD0/TWCK1
PD15	RTS1/SPI2_SPCK	PD31	SPI0_NPCS2/PCK1	PE15	LED_USER/LCD_ID/TIOA0	PE31	USBA_VBUS

JUMPER DESCRIPTION		
PART	DEFAULT	FUNCTION
JP1	OPEN	Disable EDBG
JP2	SHORT	I_VCC_3V3 Measurement
JP3	SHORT	I_1V2_HDMI Measurement
JP4	SHORT	I_VDDIODDR_MPU Measurement
JP5	SHORT	I_VDDCORE Measurement
JP6	SHORT	I_VDDDBU Measurement
JP7	OPEN	Disable CS Serial&Nand Flash Memory
JP8	DNP	CS Serial Flash Memory

RevA	XinJQ	30-Sep-14	XXX	XX-XX-XX					
INIT EDIT	XinJQ	29-Aug-14	XXX	XX-XX-XX					
REV	MODIF.	DES.	DATE	VER.	DATE				
SAMA5D4-XULT		SCALE	1/1	REV.	A	SHEET		3/15	
PIO Muxing									

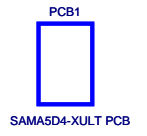
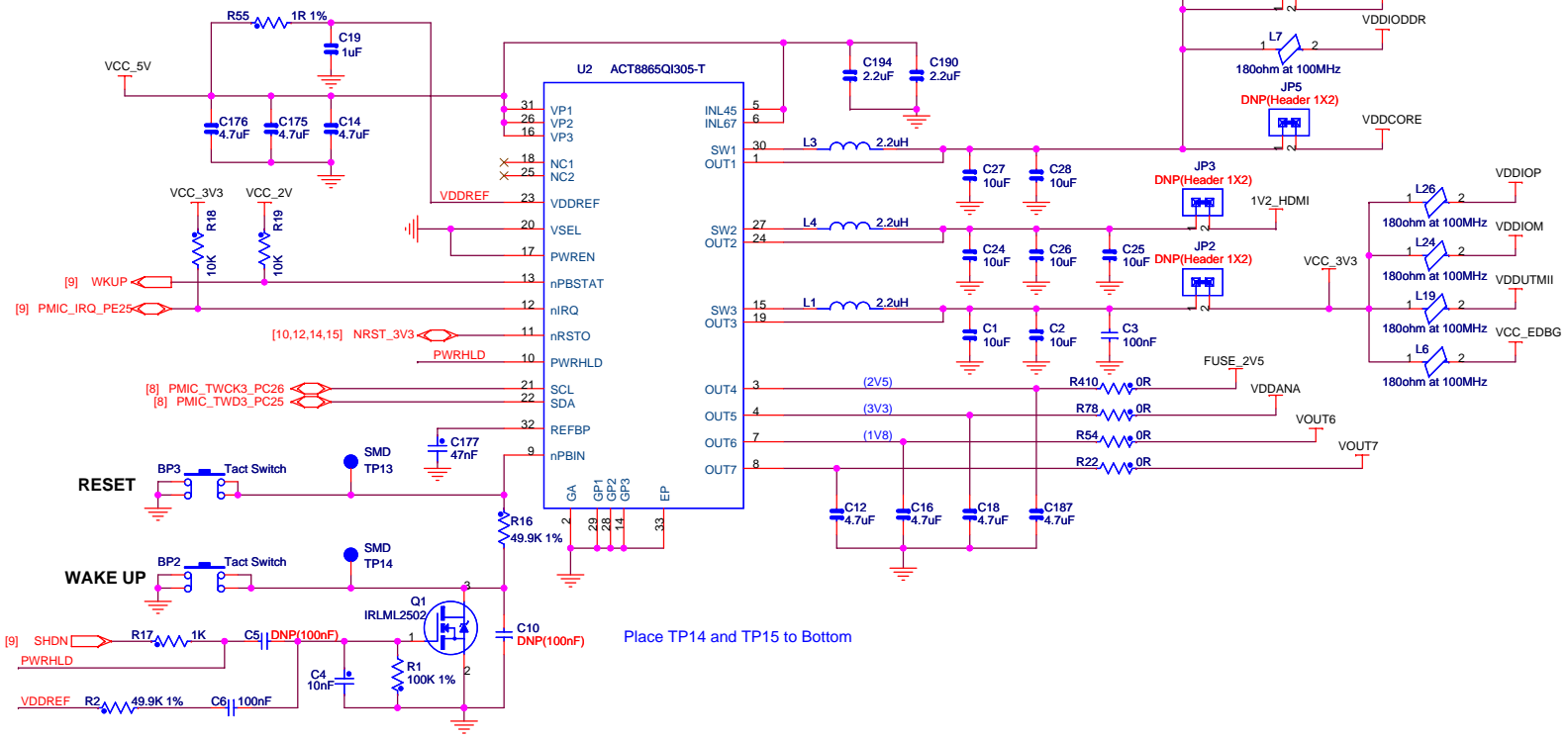
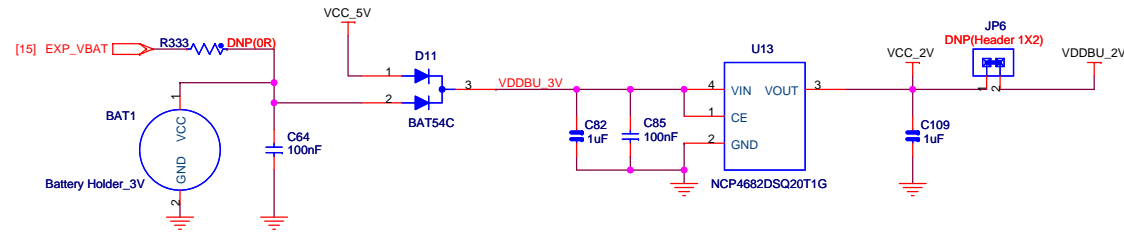
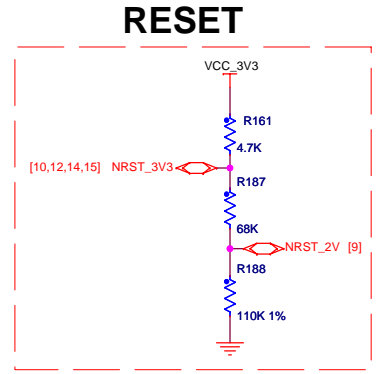
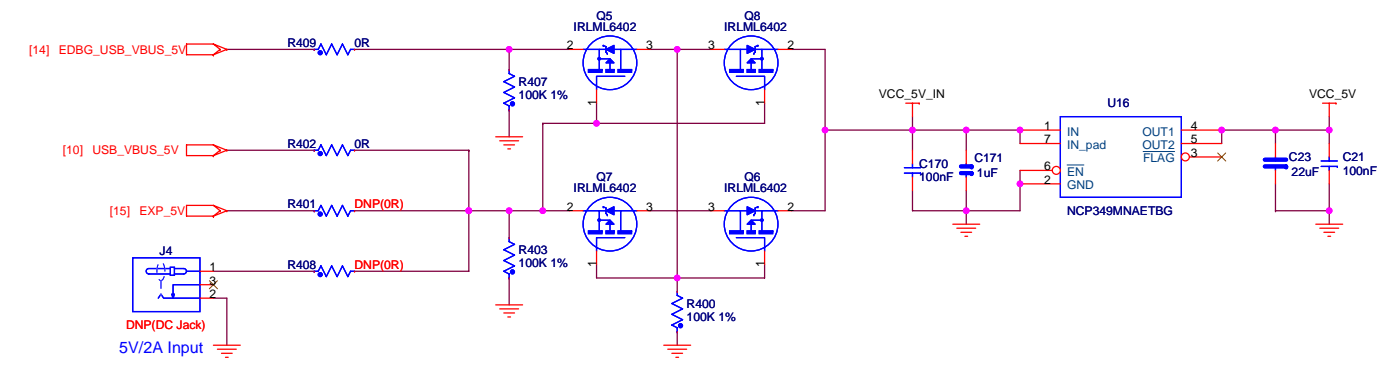

		RevA	XinJQ	30-Sep-14	XXX
RevA	INIT EDIT	XinJQ	29-Aug-14	XXX	XX-XX-XX
REV	MODIF.	DES.	DATE	VER.	DATE
SAMA5D4-XULT		SCALE 1/1		REV. A	SHEET 4/15
Power Supply					

# POWER TEST POINTS

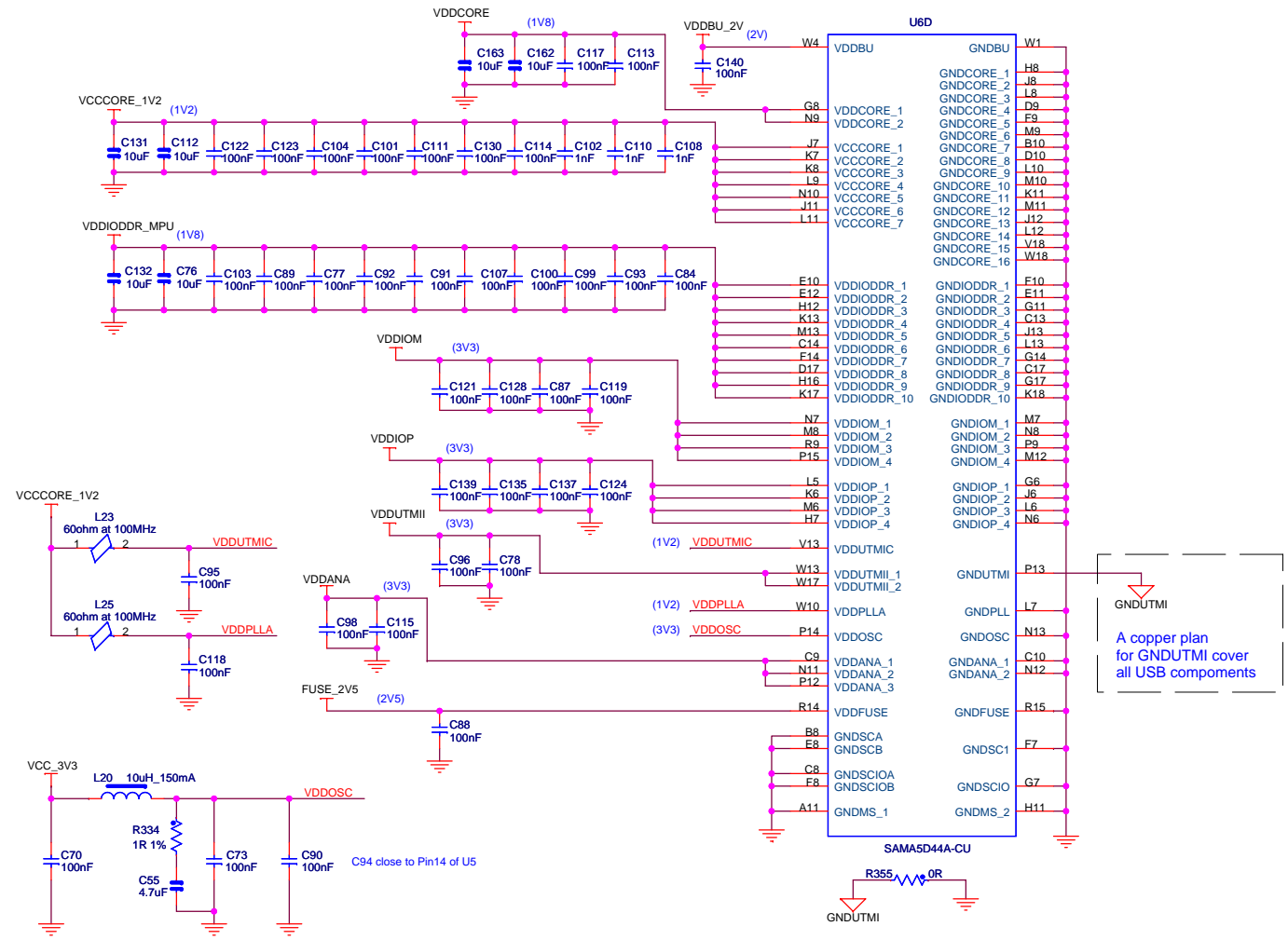
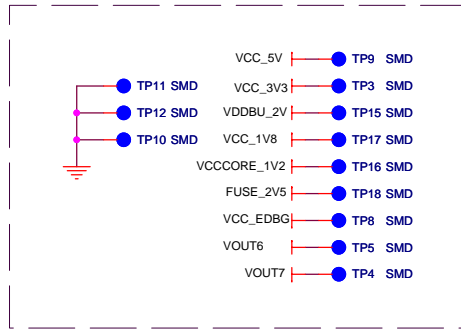

A copper plan for GNDUTMI cover all USB components

Atmel					
RevA	XinJQ	30-Sep-14	XXX	XX-XX-XX	
INIT EDIT	XinJQ	29-Aug-14	XXX	XX-XX-XX	
REV	MODIF.	DES.	DATE	REV.	DATE
SAMA5D4-XULT		SCALE	1/1	REV.	A
SAMA5D44- Power		SHEET		5/15	

MPU\_DDR2\_A0 F15  
MPU\_DDR2\_A1 E16  
MPU\_DDR2\_A2 E17  
MPU\_DDR2\_A3 B18  
MPU\_DDR2\_A4 B17  
MPU\_DDR2\_A5 C16  
MPU\_DDR2\_A6 E15  
MPU\_DDR2\_A7 F17  
MPU\_DDR2\_A8 E18  
MPU\_DDR2\_A9 D19  
MPU\_DDR2\_A10 D18  
MPU\_DDR2\_A11 D19  
MPU\_DDR2\_A12 C18  
MPU\_DDR2\_A13 D16

MPU\_DDR2\_CK+ A18  
MPU\_DDR2\_CK- A19

MPU\_DDR2\_CKE\_n D15  
MPU\_DDR2\_CS\_n B16  
MPU\_DDR2\_RAS\_n B17  
MPU\_DDR2\_CAS\_n A17  
MPU\_DDR2\_WEn E16

MPU\_DDR2\_BA0 C15  
MPU\_DDR2\_BA1 D14  
MPU\_DDR2\_BA2 G13

VDDIODDR R244 200R 1%  
R243 200R 1%  
DDR2\_VREF K12  
C97 100nF

### MCU\_DDR

U6B  
DDR\_A0 DDR\_D0  
DDR\_A1 DDR\_D1  
DDR\_A2 DDR\_D2  
DDR\_A3 DDR\_D3  
DDR\_A4 DDR\_D4  
DDR\_A5 DDR\_D5  
DDR\_A6 DDR\_D6  
DDR\_A7 DDR\_D7  
DDR\_A8 DDR\_D8  
DDR\_A9 DDR\_D9  
DDR\_A10 DDR\_D10  
DDR\_A11 DDR\_D11  
DDR\_A12 DDR\_D12  
DDR\_A13 DDR\_D13  
DDR\_D14  
DDR\_D15  
DDR\_D16  
DDR\_D17  
DDR\_D18  
DDR\_D19  
DDR\_D20  
DDR\_D21  
DDR\_D22  
DDR\_D23  
DDR\_D24  
DDR\_D25  
DDR\_D26  
DDR\_D27  
DDR\_D28  
DDR\_D29  
DDR\_D30  
DDR\_D31  
DDR\_CLK  
DDR\_CLKN  
DDR\_CKE  
DDR\_CS  
DDR\_RAS  
DDR\_CAS  
DDR\_WE  
DDR\_BA0  
DDR\_BA1  
DDR\_BA2  
DDR\_DQS0  
DDR\_DQS0N  
DDR\_DQS1  
DDR\_DQS1N  
DDR\_DQS2  
DDR\_DQS2N  
DDR\_DQS3  
DDR\_DQS3N  
DDR\_DOM0  
DDR\_DOM1  
DDR\_DOM2  
DDR\_DOM3

L14 MPU\_DDR2\_D00  
K16 MPU\_DDR2\_D01  
K15 MPU\_DDR2\_D02  
K14 MPU\_DDR2\_D03  
J18 MPU\_DDR2\_D04  
J17 MPU\_DDR2\_D05  
J15 MPU\_DDR2\_D06  
H19 MPU\_DDR2\_D07  
H18 MPU\_DDR2\_D08  
G14 MPU\_DDR2\_D09  
G14 MPU\_DDR2\_D010  
H17 MPU\_DDR2\_D011  
H15 MPU\_DDR2\_D012  
H14 MPU\_DDR2\_D013  
G16 MPU\_DDR2\_D014  
E19 MPU\_DDR2\_D015  
E14 MPU\_DDR2\_D016  
E13 MPU\_DDR2\_D017  
H13 MPU\_DDR2\_D018  
E13 MPU\_DDR2\_D019  
B15 MPU\_DDR2\_D020  
A14 MPU\_DDR2\_D021  
D12 MPU\_DDR2\_D022  
B14 MPU\_DDR2\_D023  
B13 MPU\_DDR2\_D024  
G12 MPU\_DDR2\_D025  
B12 MPU\_DDR2\_D026  
C12 MPU\_DDR2\_D027  
E11 MPU\_DDR2\_D028  
C11 MPU\_DDR2\_D029  
D11 MPU\_DDR2\_D030  
B11 MPU\_DDR2\_D031  
J19 MPU\_DDR2\_DQS0+  
K19 MPU\_DDR2\_DQS0-  
F19 MPU\_DDR2\_DQS1+  
G19 MPU\_DDR2\_DQS1-  
A15 MPU\_DDR2\_DQS2+  
A16 MPU\_DDR2\_DQS2-  
A12 MPU\_DDR2\_DQS3+  
A13 MPU\_DDR2\_DQS3-  
L16 MPU\_DDR2\_DM0  
J16 MPU\_DDR2\_DM1  
D13 MPU\_DDR2\_DM2  
F12 MPU\_DDR2\_DM3

SAMA5D44A-CU

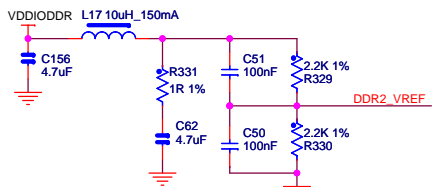

Keep nets as short as possible, therefore, DDR2 devices have to be placed close as possible of SAMA5D44  
The layout EBI\_DDR2 should use controlled impedance traces of ZO>= 50ohm characteristic impedance.  
Address, control and data traces may not exceed 1.3 inches (33.0 mm).  
Address, control and data traces must be length-matched to within 0.1 inch (2.54mm).  
Address, control and data traces must match the data group trace lengths to within 0.25 inches (6.35mm).

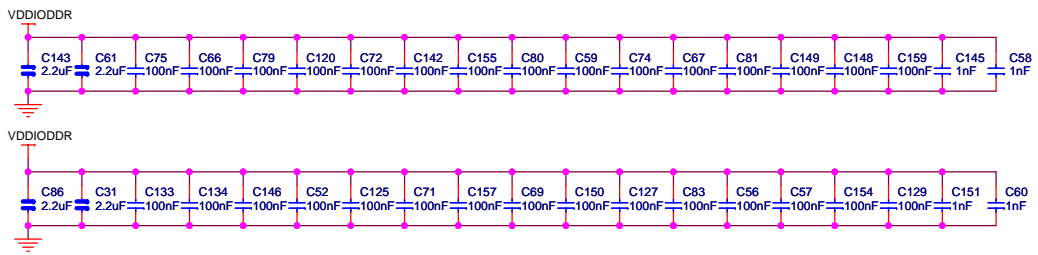

100 ohms differential trace impedance  
Routing top or bottom

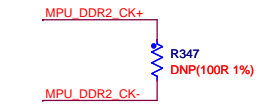
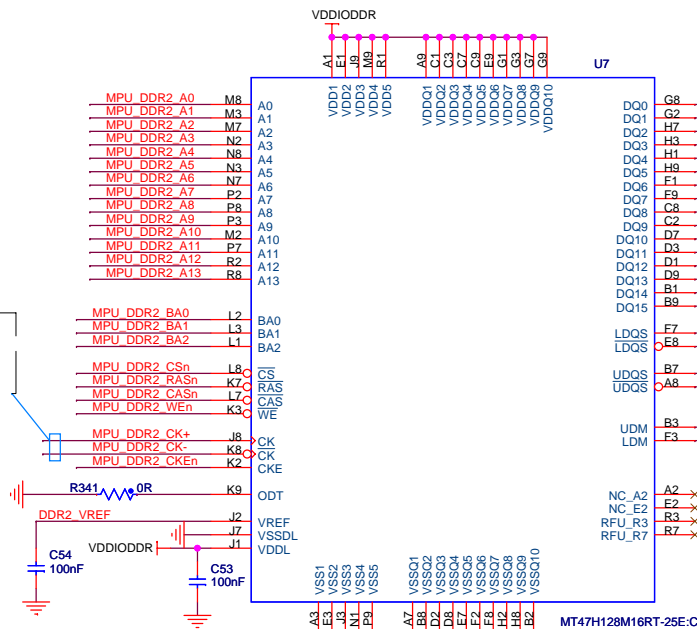

### DDR2

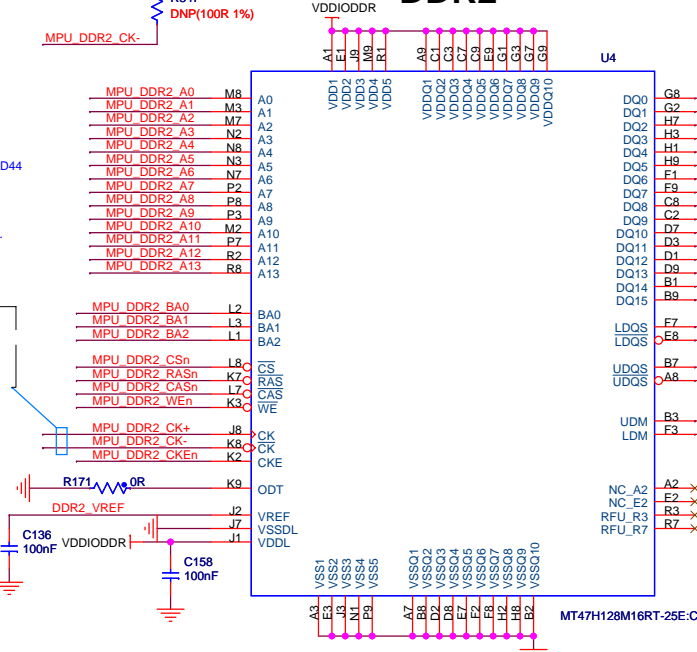

Atmel

RevA	XinJi	30-Sep-14	XXX	XX-XX-XX
INIT EDIT	XinJi	29-Aug-14	XXX	XX-XX-XX
REV	MODIF.	DES.	DATE	VER.
SCALE 1/1			REV. A	SHEET 6/15

# PIOA

U6A

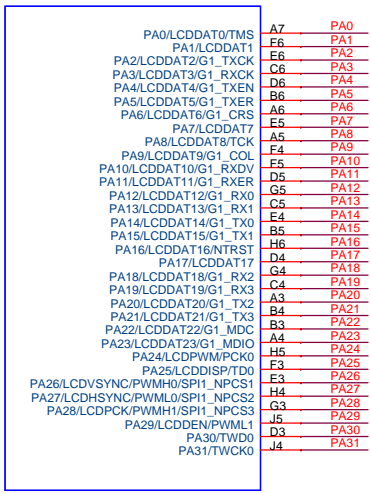

SAMA5D44A-CU

# PIOB

U6E

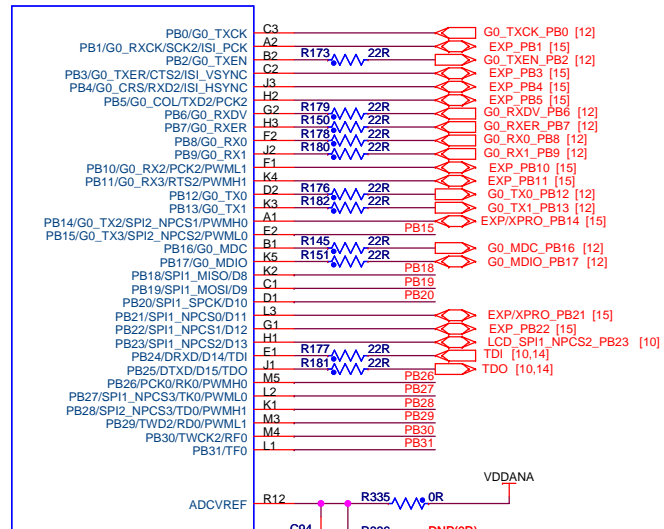

SAMA5D44A-CU

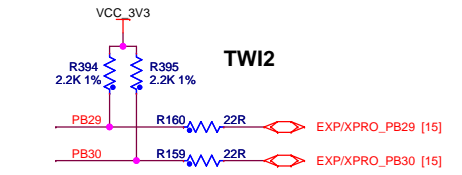
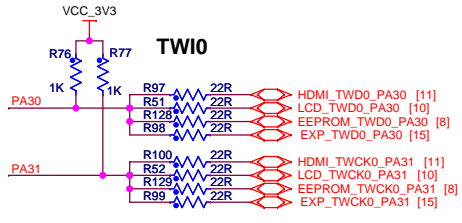
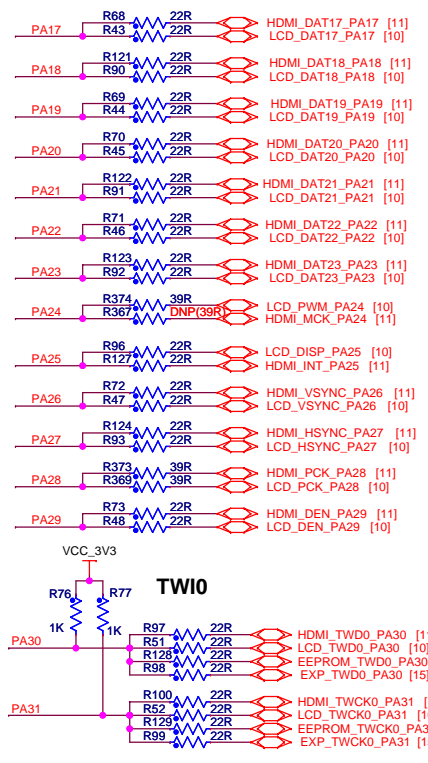
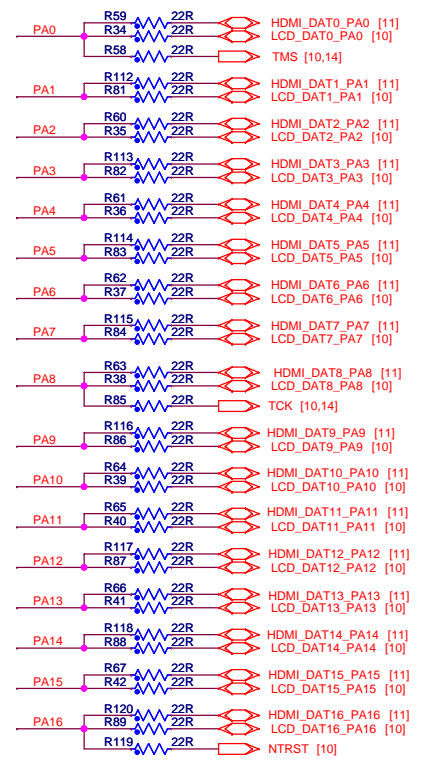
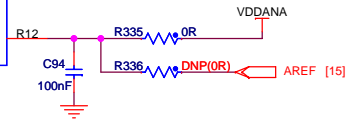

Atmel									
A	RevA	XinJQ	30-Sep-14	XXX	XX-XX-XX				
A	INIT EDIT	XinJQ	29-Aug-14	XXX	XX-XX-XX				
REV	MODIF.	DES.	DATE	VER.	DATE				
SAMA5D4-XULT		SCALE	1/1	REV.	A	SHEET			
SAMA5D44- PIOA & PIOB						7/15			

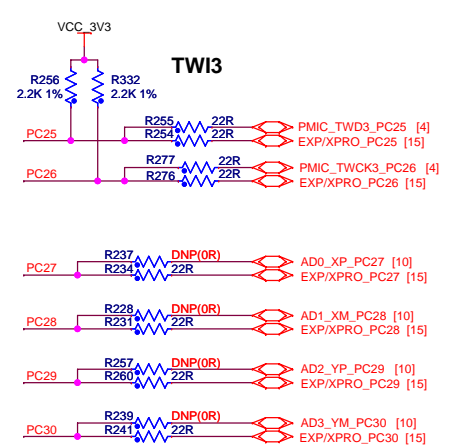
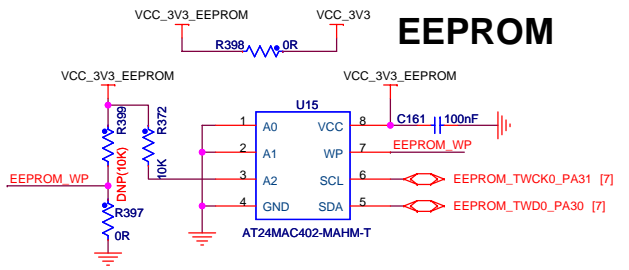
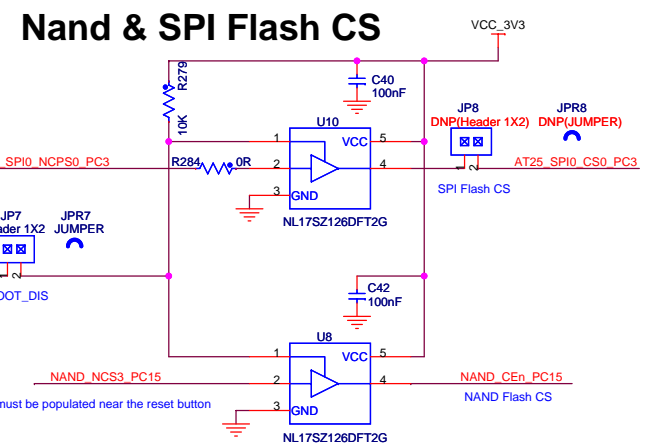
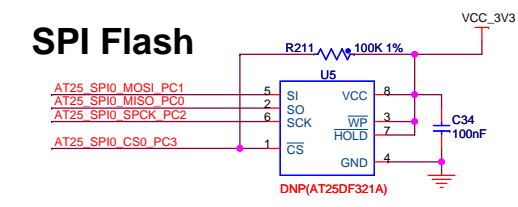
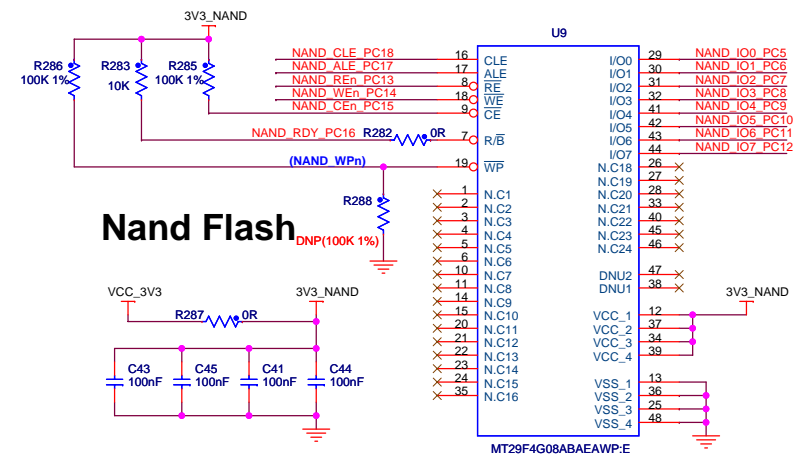
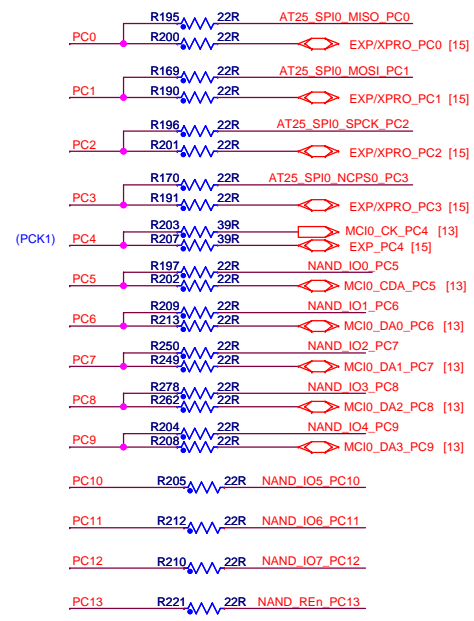
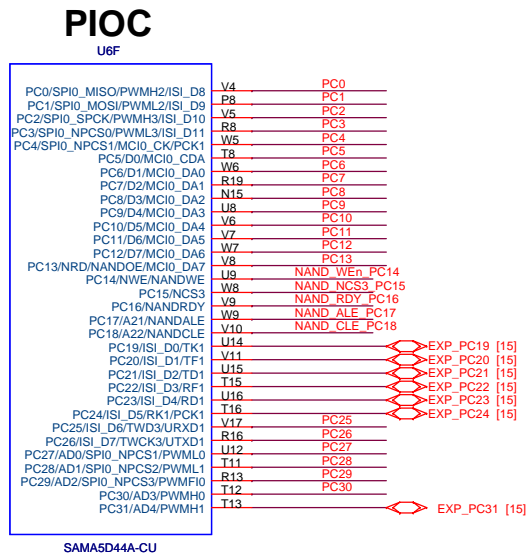

Atmel		RevA	XinJQ	30-Sep-14	XXX	XX-XX-XX
		INIT EDIT	XinJQ	29-Aug-14	XXX	XX-XX-XX
SAMA5D4-XULT		SCALE	1/1	REV.	A	SHEET 8/15
SAMA5D4- PIOC & FLASH						



# PIOD

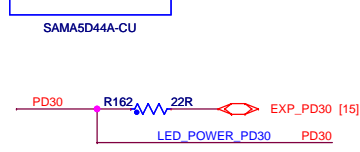
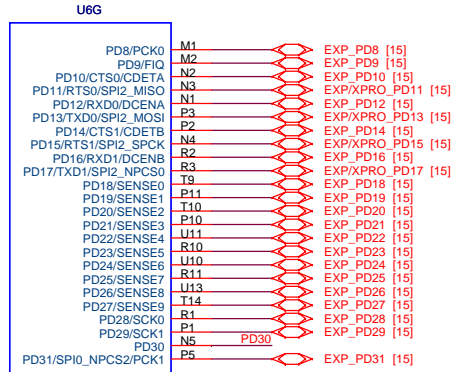

# PIOE

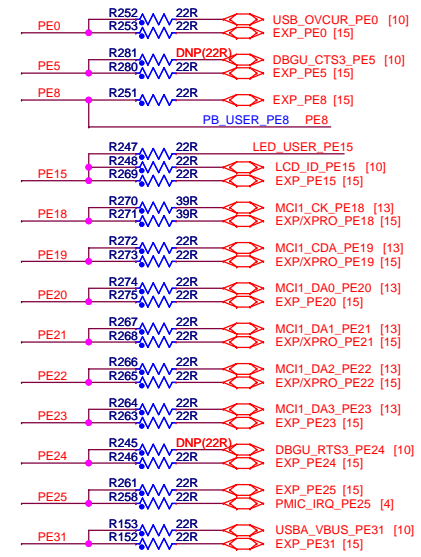
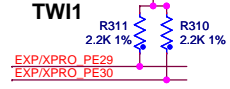
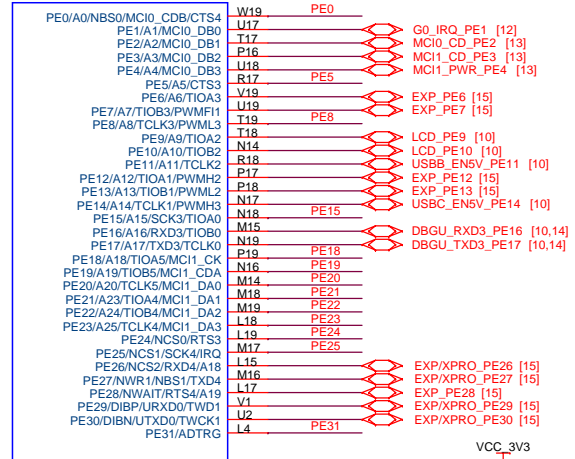

# SYS

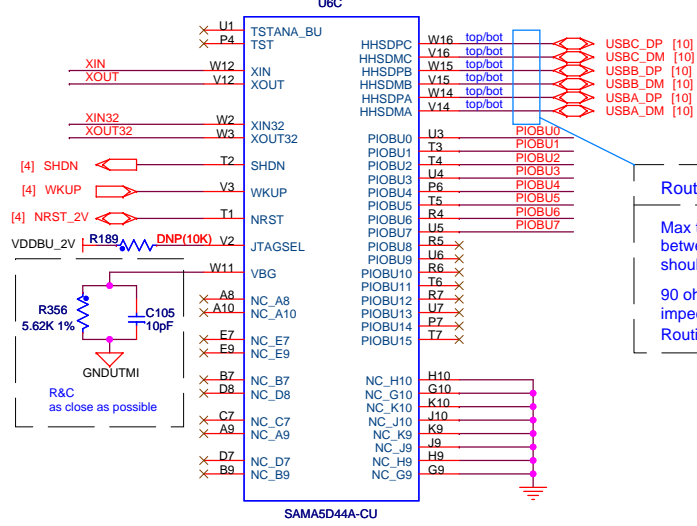

**Routing USB**

Max trace-length mismatch between USB signals pairs should be no greater than 3.8mm

90 ohms differential trace impedance

Routing top or bottom

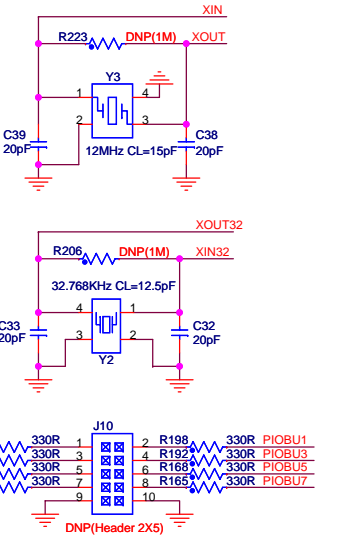

# LED

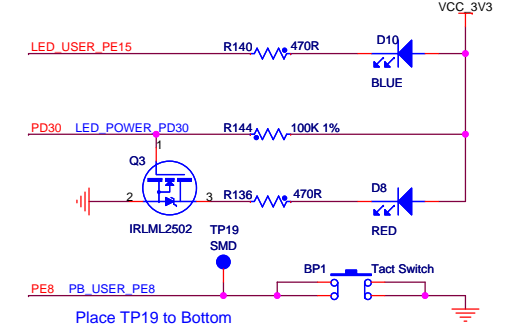

# USER BUTTON

Atmel							
A	RevA	XinJQ	30-Sep-14	XXX	XX-XX-XX		
A	INIT EDIT	XinJQ	29-Aug-14	XXX	XX-XX-XX		
REV	MODIF.	DES.	DATE	VER.	DATE		
SAMA5D4-XULT				SCALE	1/1	REV.	A
SAMA5D44- SYS & PIOD & PIOE						SHEET	9/15

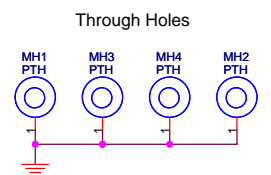
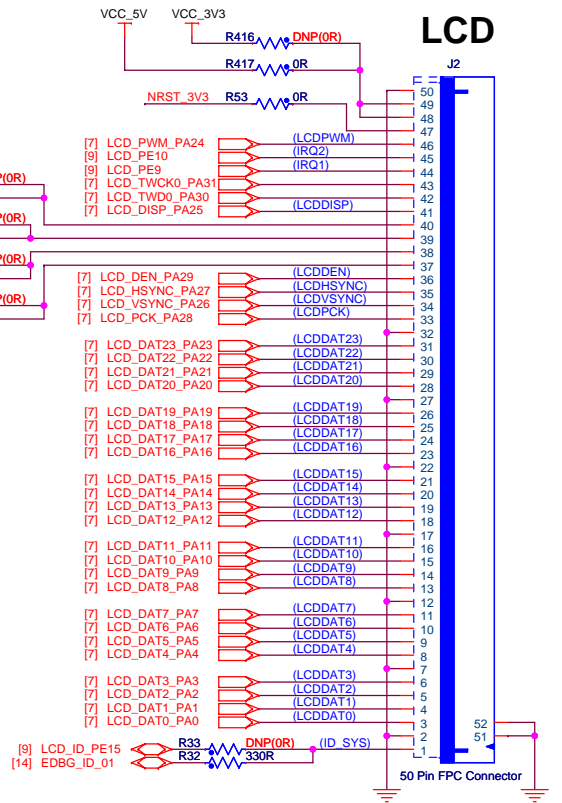
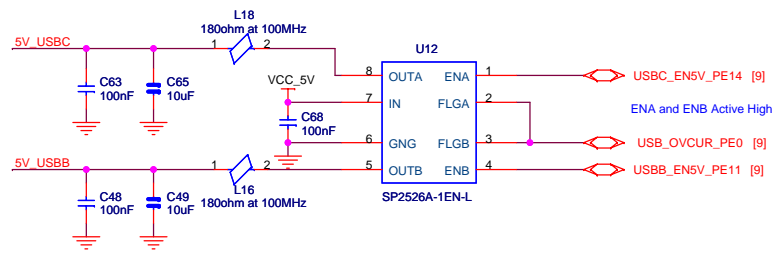
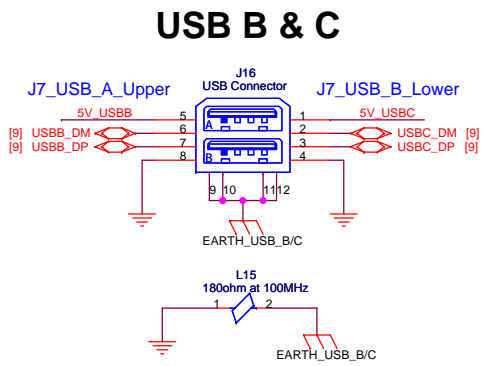
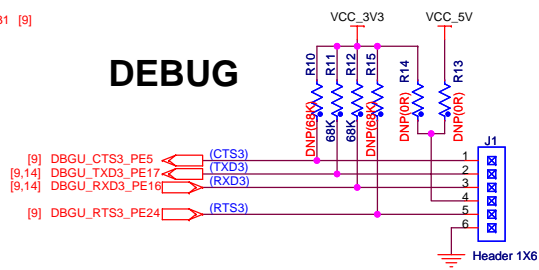
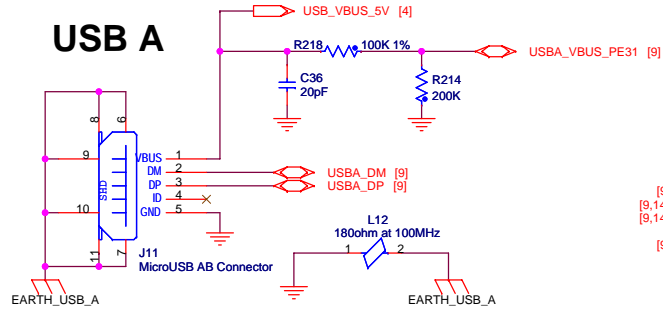
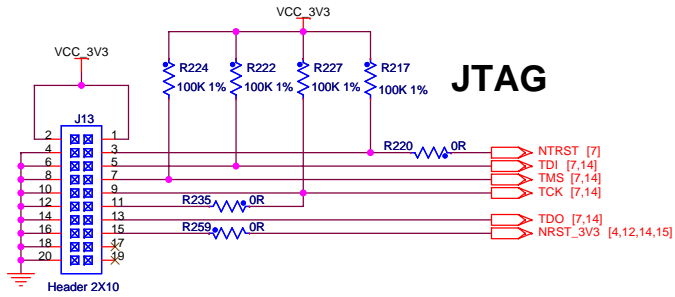

		RevA	XinJQ	30-Sep-14	XXX	XX-XX-XX
SAMA5D4-XULT		INIT EDIT	XinJQ	29-Aug-14	XXX	XX-XX-XX
TAG & USB & DEBUG & LCD		REV. MODIF.	DES.	DATE	VER.	DATE
SCALE 1/1					A	SHEET 10/15

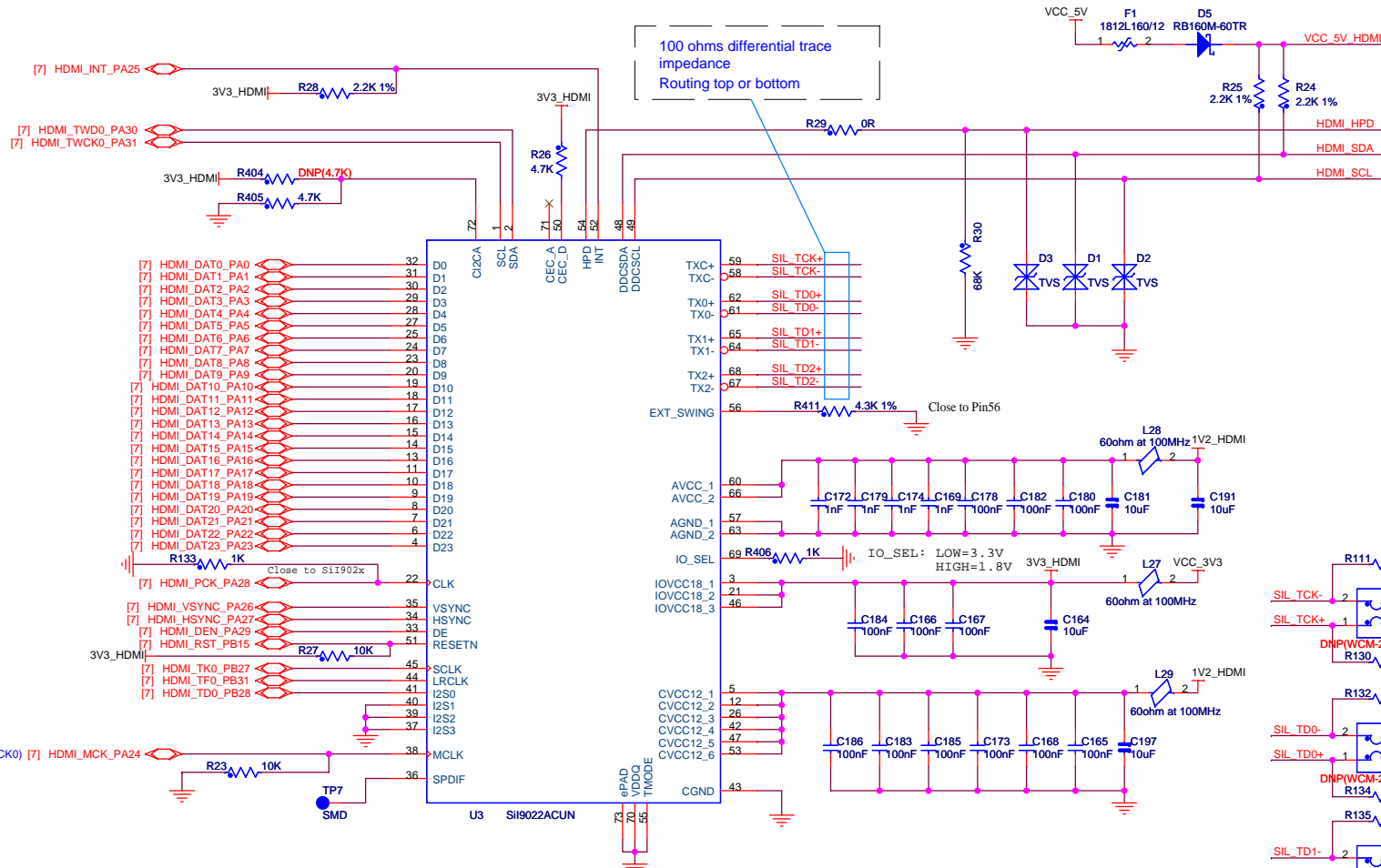

# HDMI

## HDMI Type A Connector

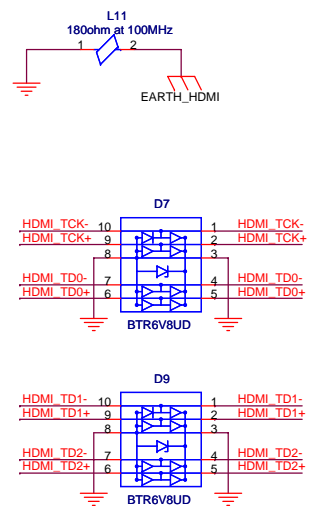
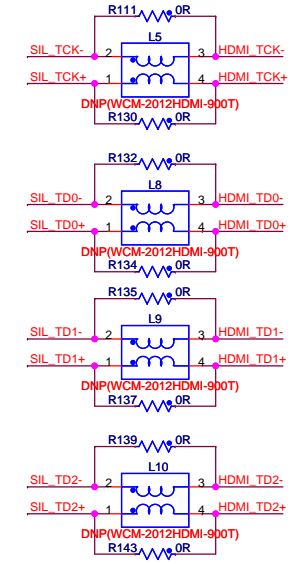
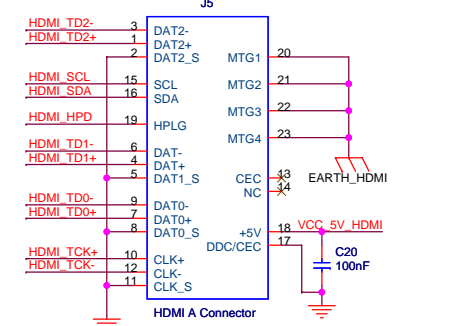

Atmel

RevA	XinJQ	30-Sep-14	XXX	XX-XX-XX
INIT EDIT	XinJQ	29-Aug-14	XXX	XX-XX-XX
REV	MODIF.	DES.	DATE	REV.
SCALE 1/1				REV. A
SAMA5D4-XULT				SHEET 11
HDMI				15

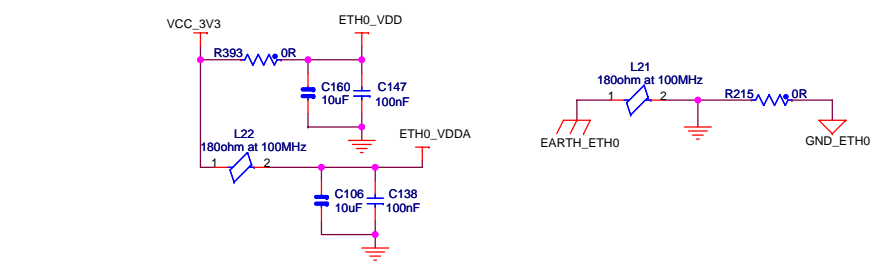
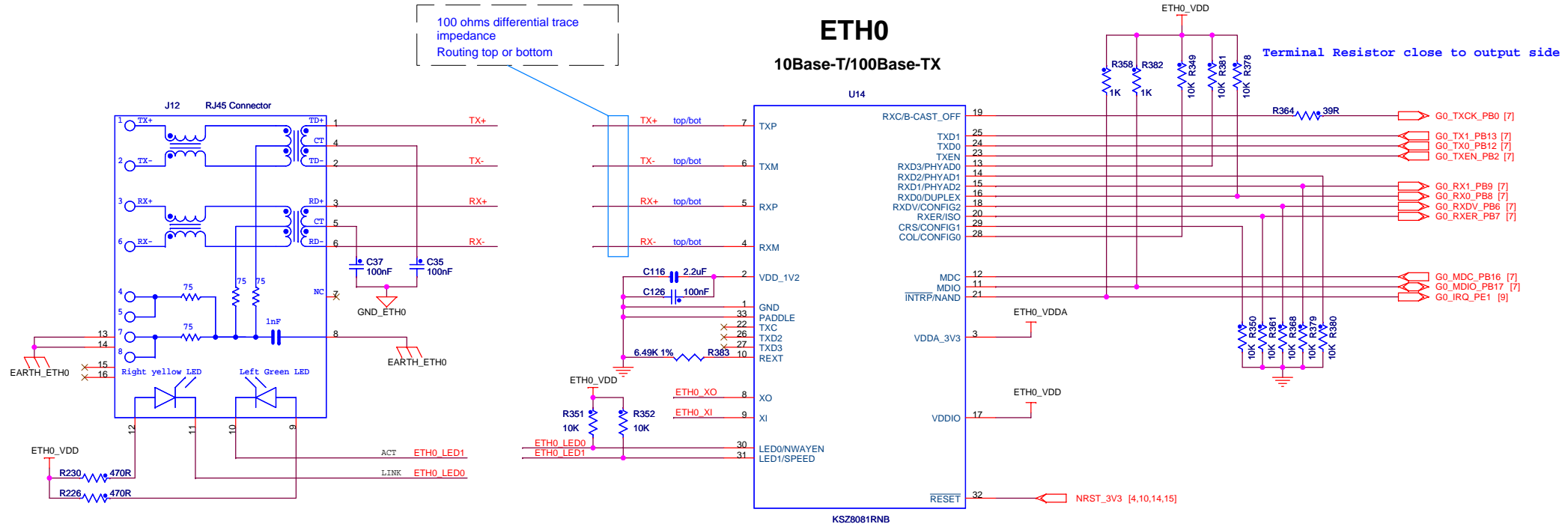

At the De-Assertion of Reset:  
 PHY ADD[2:0]-pin15/14/13: 001 = 1  
 CONFIG[2:0]-pin18/29/28:001,RMII mode  
 Duplex Mode-pin16: 1,Half Duplex  
 Isolate Mode-pin20: 0,Disable  
 Speed Mode-pin31: 1,100Mbps  
 Nway Auto-Negotiation-p30: 1,Enable

Atmel							
A	RevA	XinJQ	30-Sep-14	XXX	XX-XX-XX		
A	INIT EDIT	XinJQ	29-Aug-14	XXX	XX-XX-XX		
REV	MODIF.	DES.	DATE	VER.	DATE		
SAMA5D4-XULT				SCALE	1/1	REV.	A
Ethernet_ETH0_10/100M				SHEET		12/15	

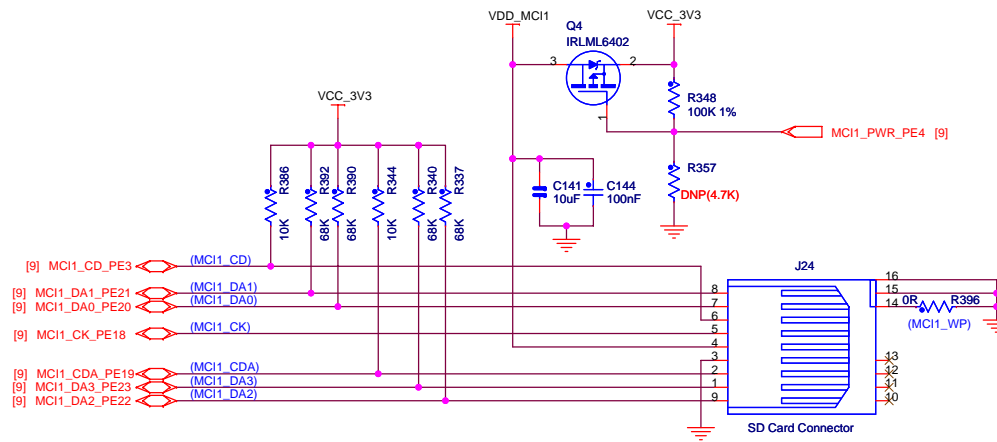

SD/MMCPlus CARD INTERFACE - MC11

SD/Micro SD CARD

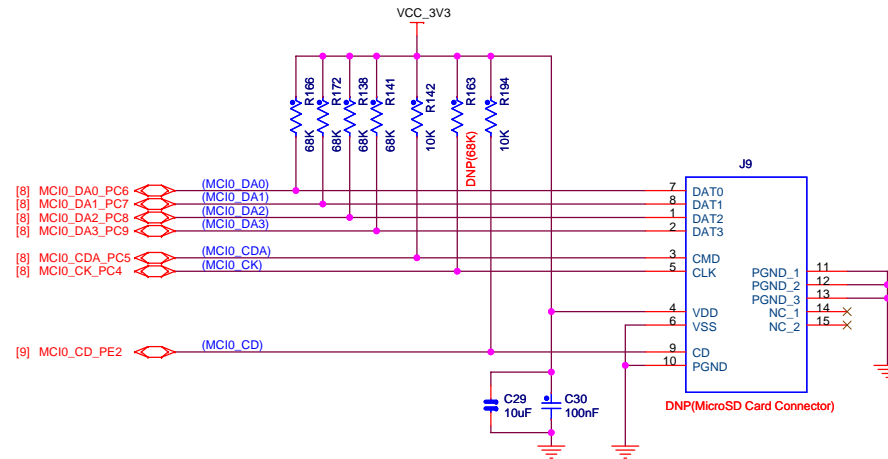

Micro SD CARD INTERFACE - MC10

Atmel					
RevA	XinJQ	30-Sep-14	XXX	XX-XX-XX	
INIT EDIT	XinJQ	29-Aug-14	XXX	XX-XX-XX	
REV	MODIF.	DES.	DATE	VER.	DATE
SAMA5D4-XULT	SCALE 1/1			REV. A	SHEET 13/15
HSMCI					

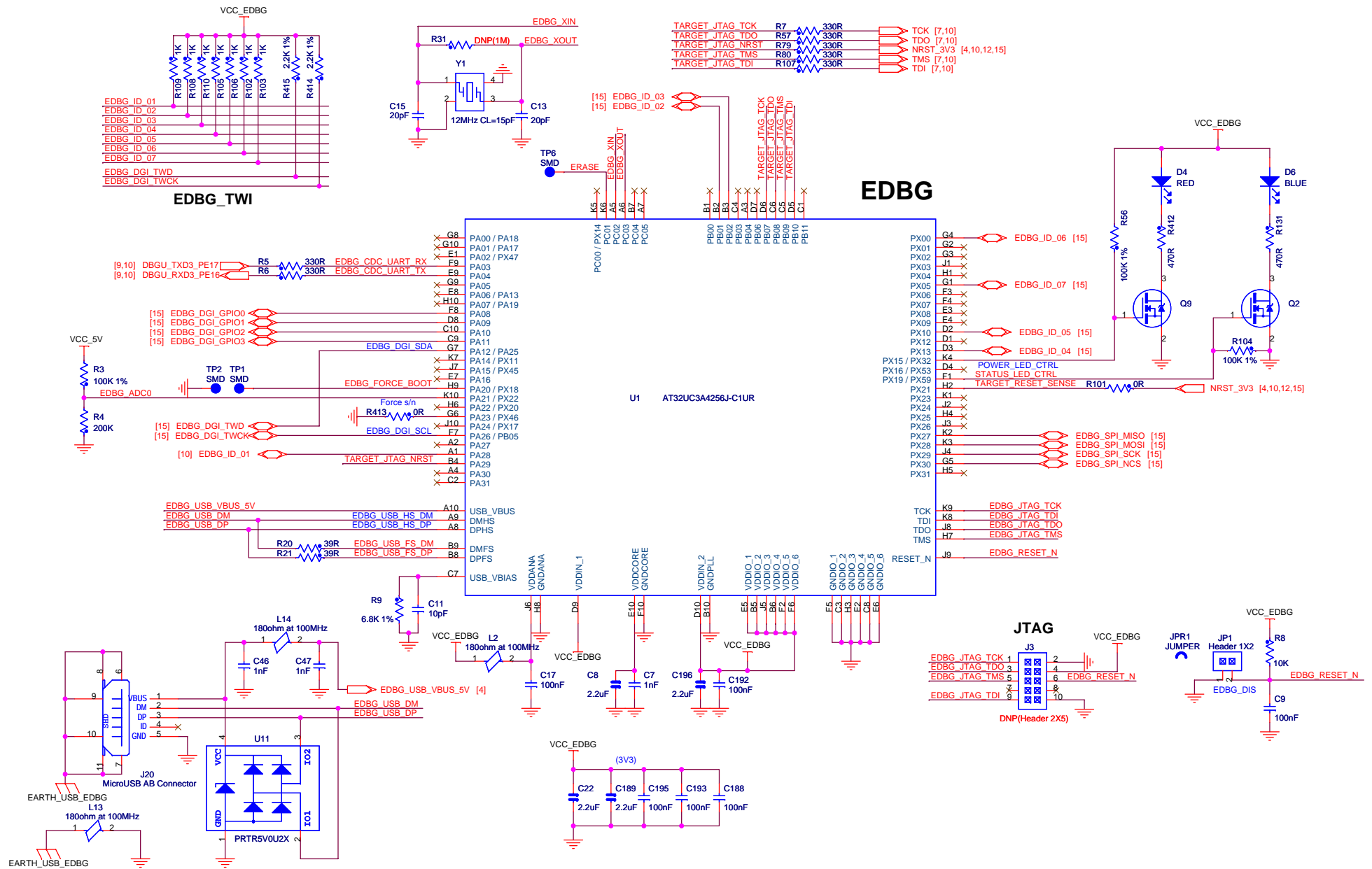

Atmel		RevA		XinJQ		30-Sep-14		XXX		XX-XX-XX	
		INIT EDIT		XinJQ		29-Aug-14		XXX		XX-XX-XX	
SAMA5D4-XULT		SCALE 1/1		REV. A		SHEET 14		DATE		DATE	
EDBG		SCALE 1/1		REV. A		SHEET 14		DATE		DATE	

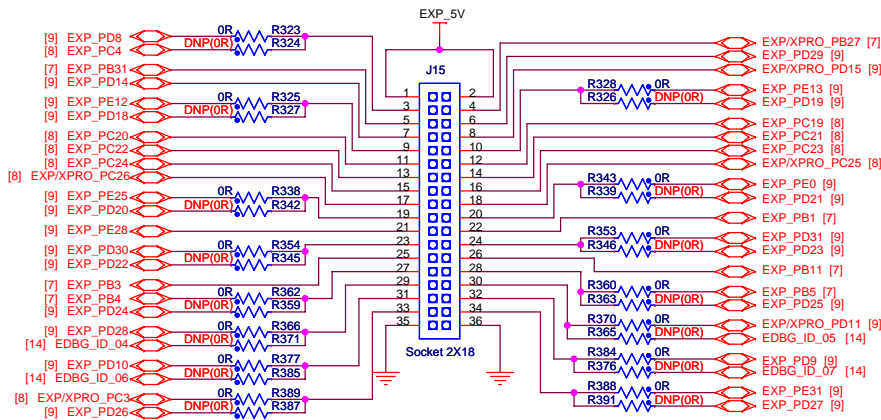
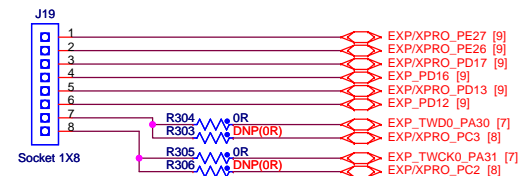
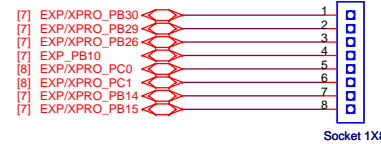
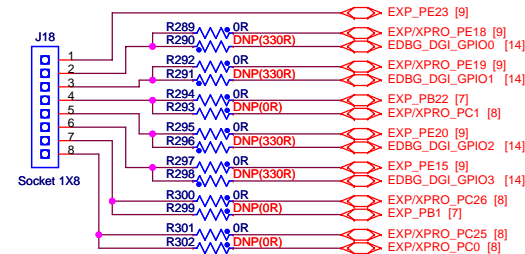
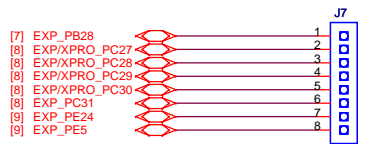
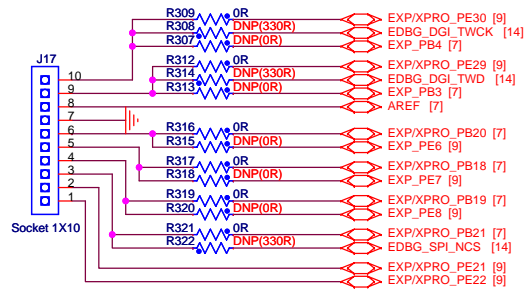
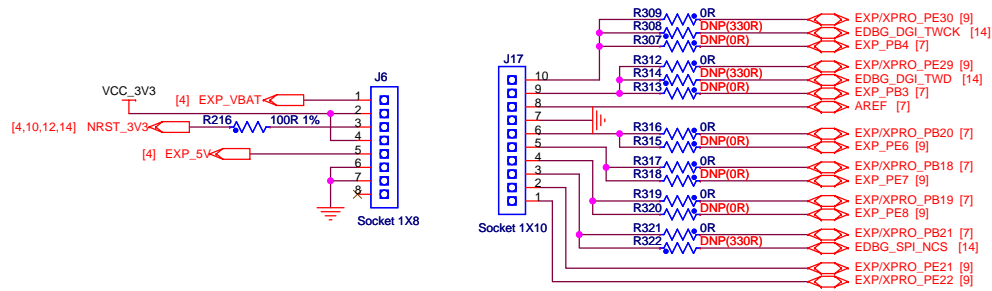

## Expansion Boards Connectors

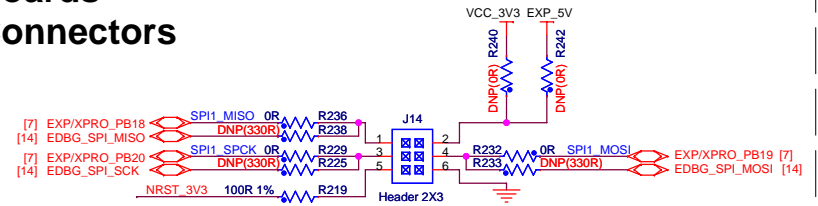

### XPRO Power

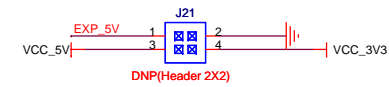

### XPRO EXT1

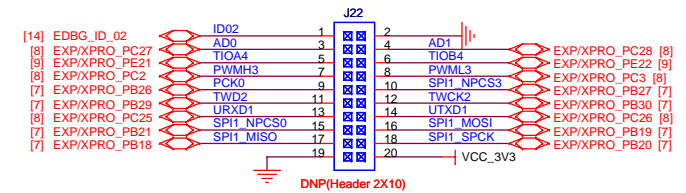

### XPRO EXT2

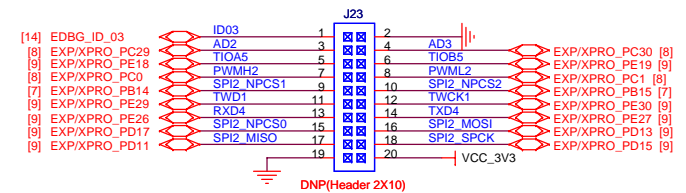

## XPRO Connectors

Atmel		SAMA5D4-XULT		Expansion & XPRO Connectors	
RevA	XinJQ	30-Sep-14	XXX	XX-XX-XX	XX-XX-XX
INIT EDIT	DES.	DATE	REV.	DATE	DATE
SCALE 1/1	REV. A			SHEET 15	