

SABRE Lite

INDEX

SCHEMATIC	PAGE
01.CONVER PAGE	01
02.Schematic History	02
03.BLOCK DIAGRAM	03
04.CPU POWER	04
05.IMX6Q_DDR3	05
06.IMX6Q_SOC	06
07.IMAX6_INTERFACE	07
08.DDR3	08
09.USB PORTS	09
10.LVDS/HDMI/CAMERA	10
11.MULTIMEDIA SGTL500	11
12.MMC/SATA/SPI FLASH	12
13.RGMII	13
14.DIAGNOSTIC/ALERT	14
15.RGB DISPLAY MIPI UART	15
16.CAN BUS	16
17.SYSTEM POWER	17

Design	<design>	element14		
Review	<review>	Title SABRE Lite		
Authorize	<authorize>	Size	Doc Name	Ver.
Standardize	<standardize>	A3	01.CONVER PAGE	D
		Date	Wednesday, October 31, 2012	Sheet 1 of 17

Schematic History

2012-07-09 Changes from SABRE Lite RevC

- 1.REPLACED THE 1.2 VOLT POWER FOR "NVCC_PLL_OUT" WITH LINEAR REGULATOR U23
- 2.REPLACED THE CAN CONTROLLER WITH NXP TJA1040T U18
- 3.MODIFIED J24A TO SUPPORT GIGA BIT ETHERNET

Design	<design>	element14		
Review	<review>			
Authorize	<authorize>	Title SABRE Lite		
Standardize	<standardize>	Size	Doc Name	Ver.
		A3	02.Schematic History	D
		Date	Wednesday, October 31, 2012	Sheet 2 of 17

SABER Lite REV-D

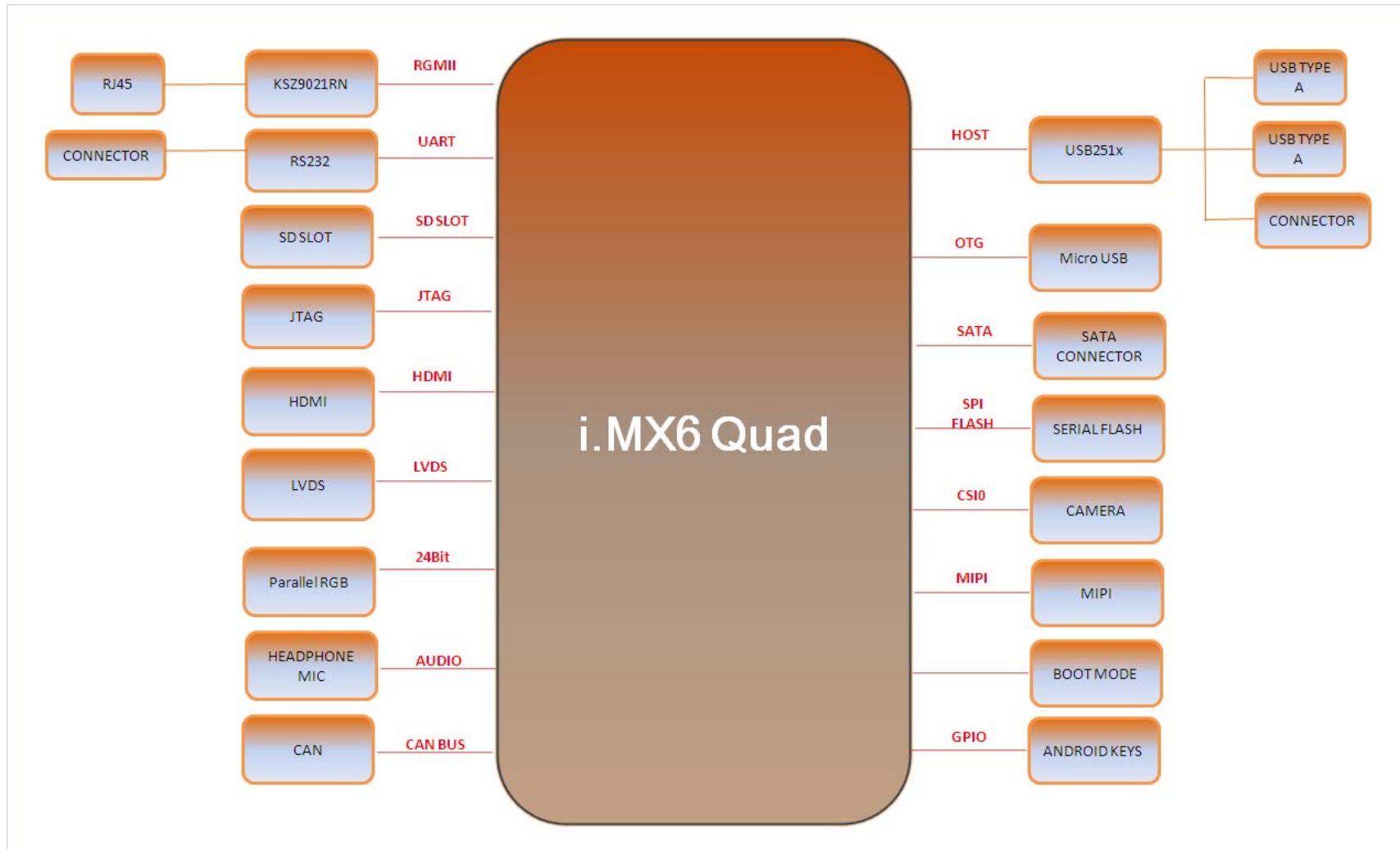

Design	<design>	element14		
Review	<review>			
Authorize	<authorize>	Size	Doc Name	Ver.
Standardize	<standardize>	A3	03.BLOCK DIAGRAM	D
		Date	Wednesday, October 31, 2012	Sheet 3 of 17

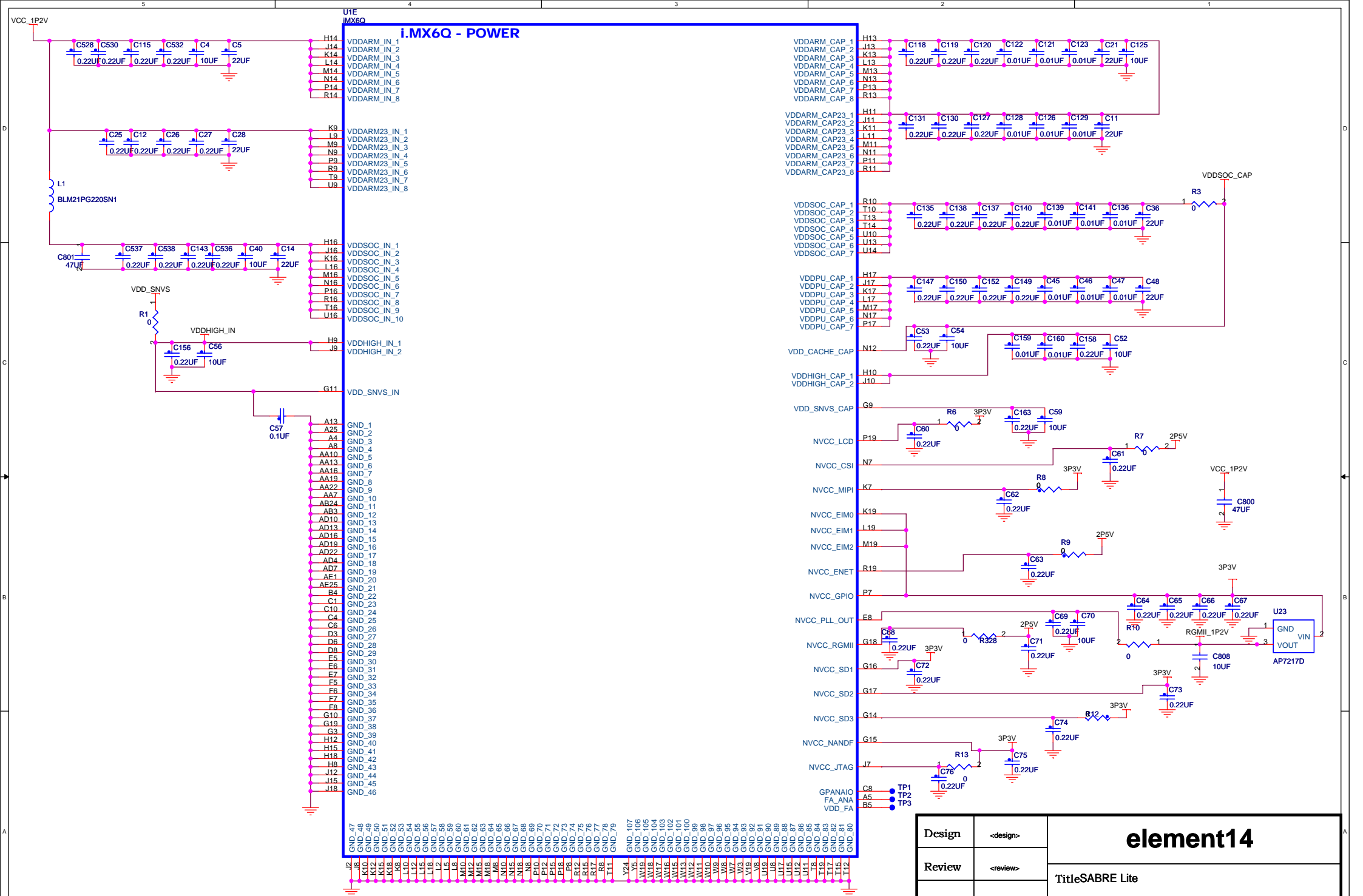

Design	<design>	element14		
Review	<review>			
Authorize	<authorize>	Title SABRE Lite		
Standardize	<standardize>	Size	Doc Name	Ver.
		A3	04.CPU POWER	D
		Date	Wednesday, October 31, 2012	Sheet 4 of 17

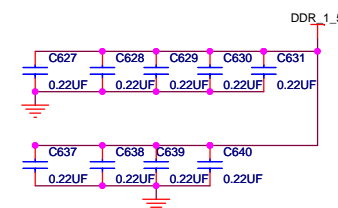
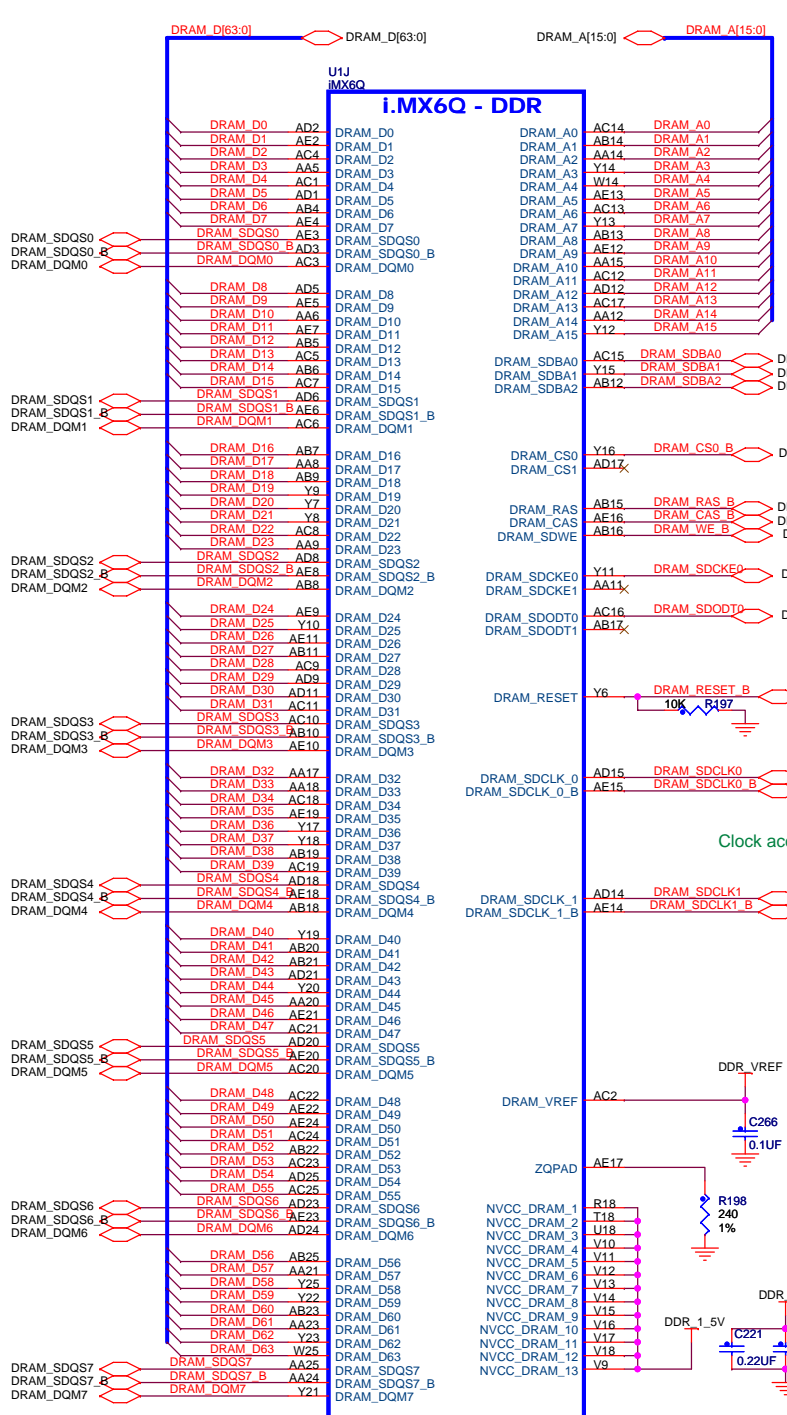

Termination Options

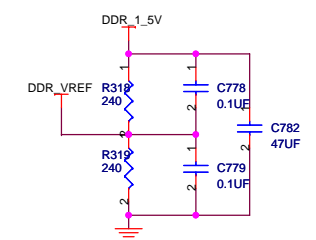
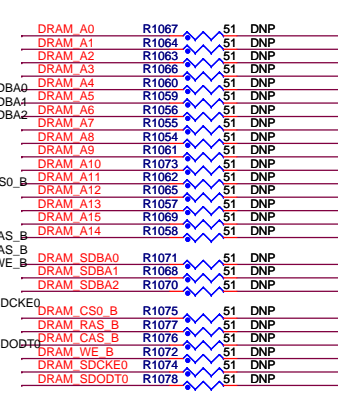

DDR_VTT supply requirements
 400mA worst case
 Supply needs to sink and source DDR_VTT
 $(25 * (0.75V/51ohms)) = 368 \text{ mA}$

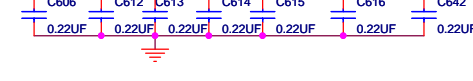
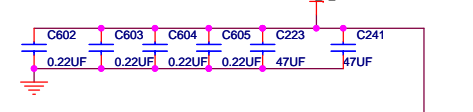
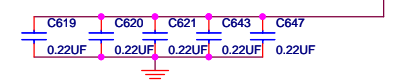
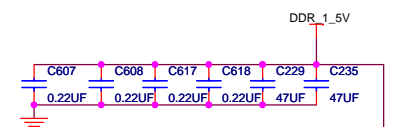
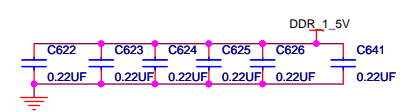

Butler Tpoint routing area

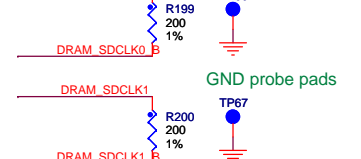
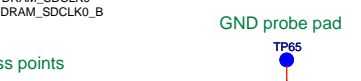
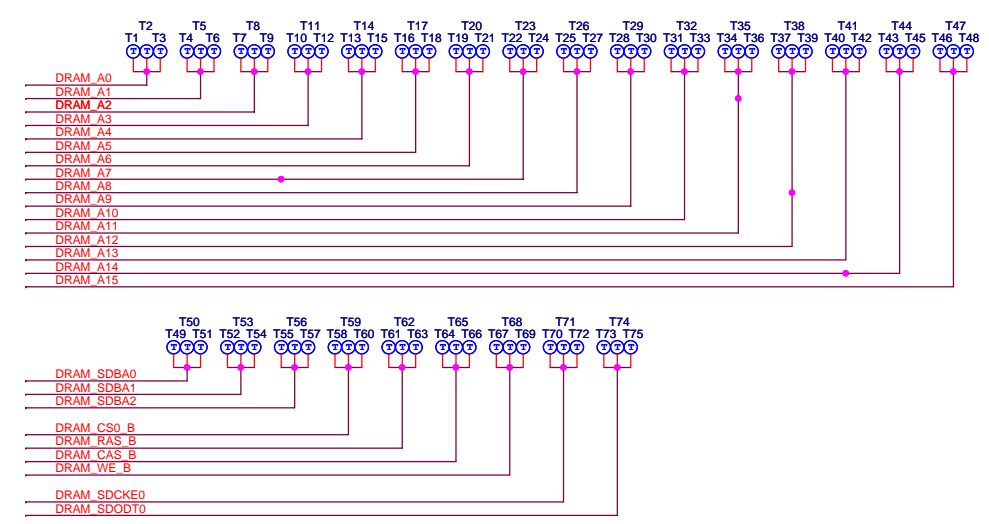

NOTES:
 Using bit swapping for DATA bus to allow easy pcb routing.
 When using data bit swapping the low order bit of each byte must reside at bit 0 of the byte. The remaining 7 data bits can be swapped freely. This restriction is for write leveling calibration.
 Example D0 to D0 or D0 to D8, and D1-7 can be swapped.
 When swapping byte lanes on 16-bit memories, remember to move the DQMx, DQSx, and DQSx_B signals for that byte lane.

Design	<design>	element14		
Review	<review>			
Authorize	<authorize>	Title SABRE Lite		
Standardize	<standardize>	Size A3	Doc Name 05.IMX6Q_DDR3	Ver. D
		Date Wednesday, October 31, 2012	Sheet 5 of 17	

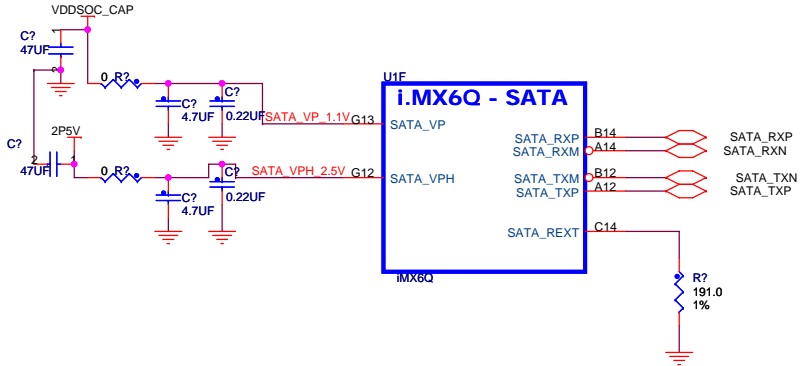
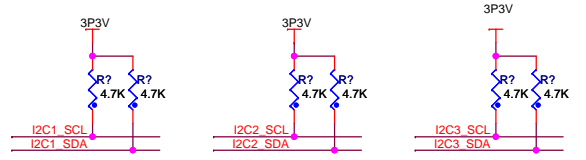
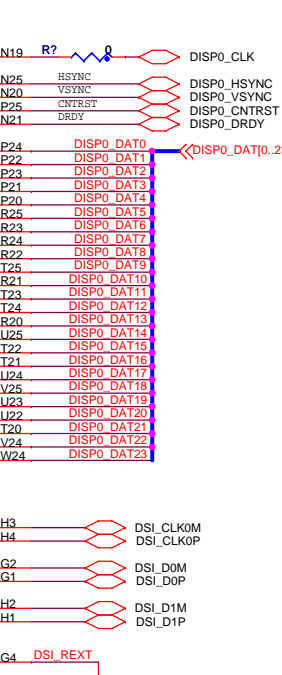
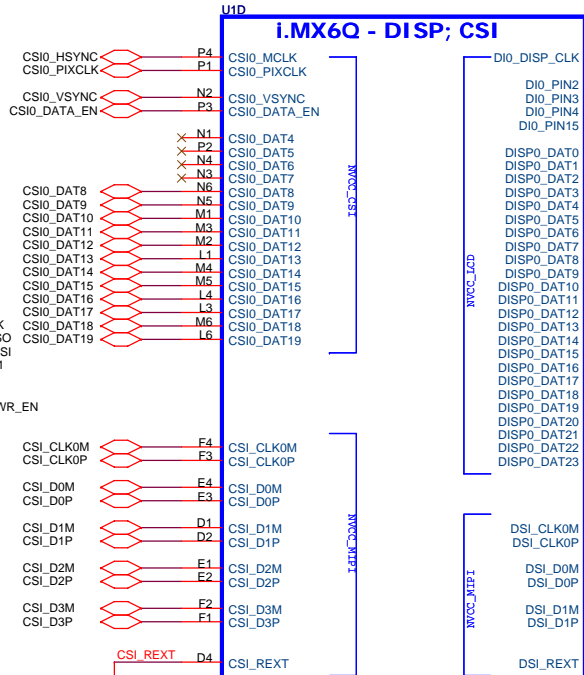
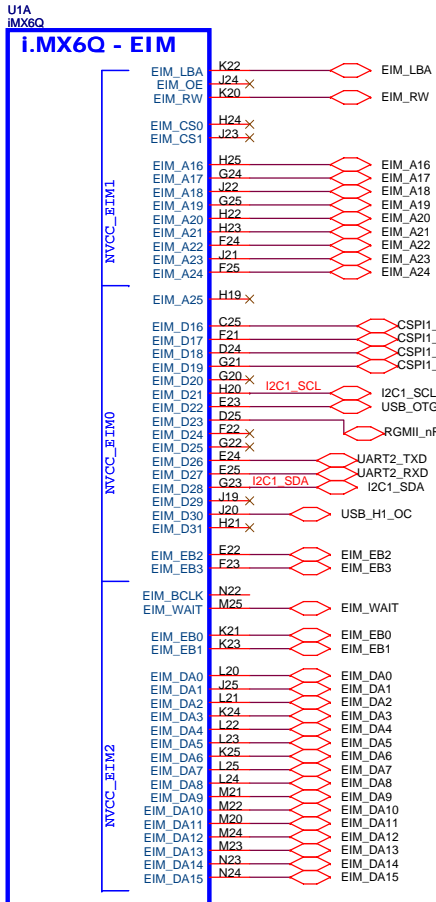

Design	<design>	element14		
Review	<review>			
Authorize	<authorize>	Title SABRE Lite		
Standardize	<standardize>	Size	Doc Name	Ver.
		A3	06.IMX6Q_SOC_A	D
		Date	Wednesday, October 31, 2012	Sheet 6 of 17

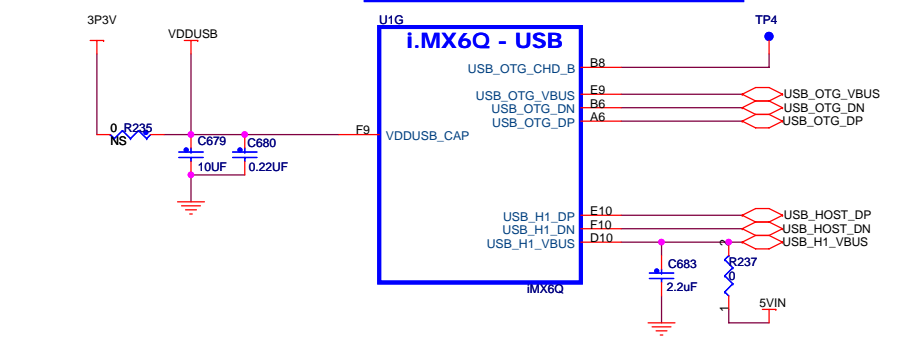
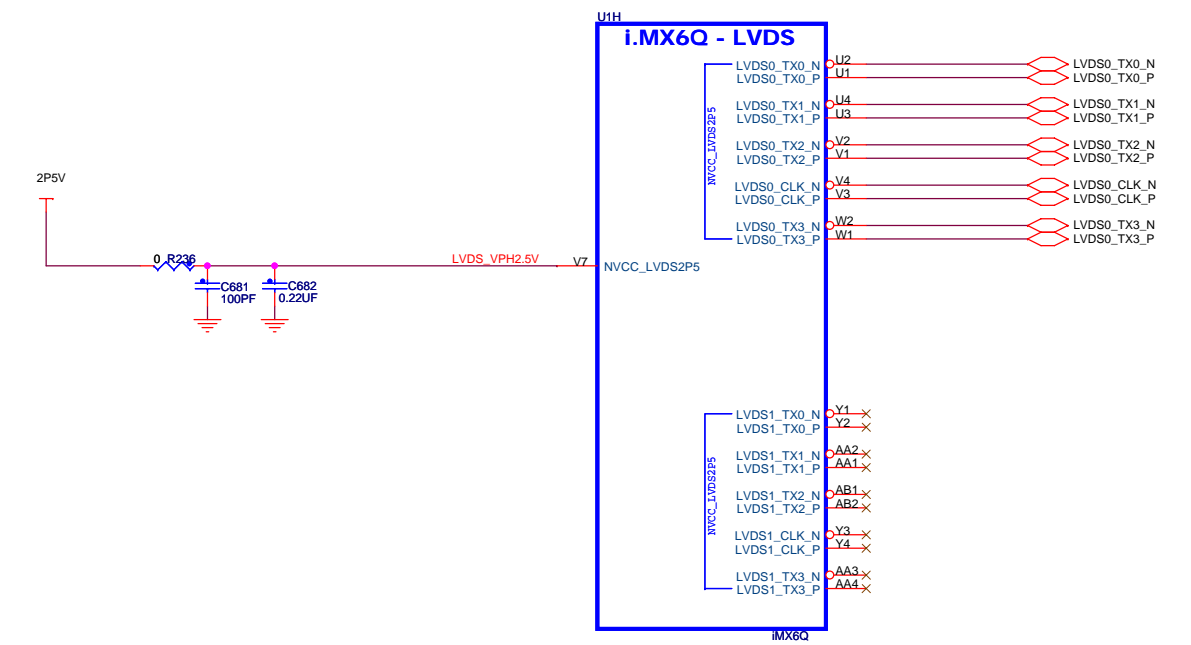
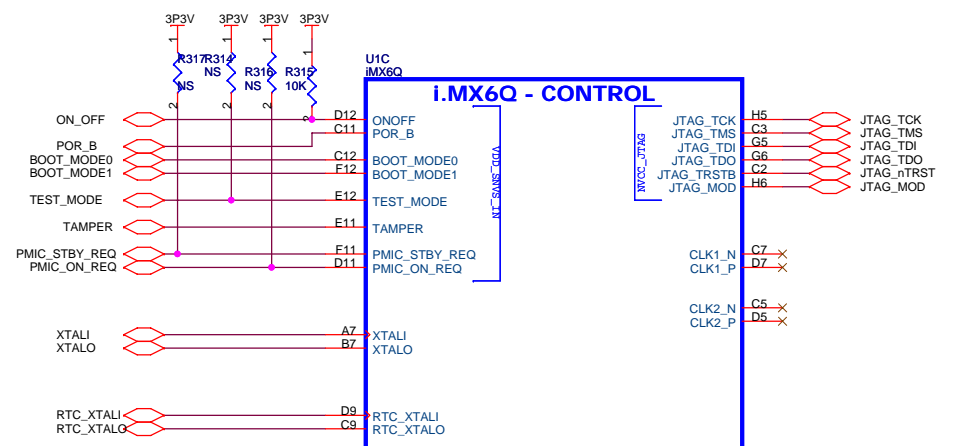
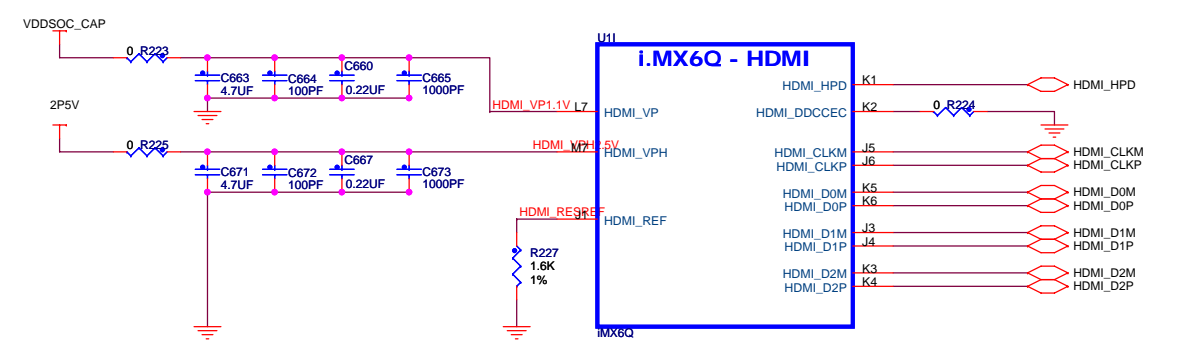
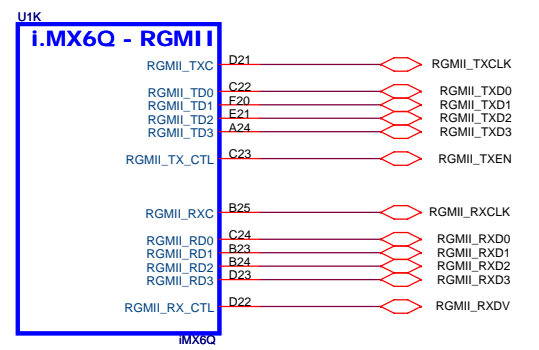
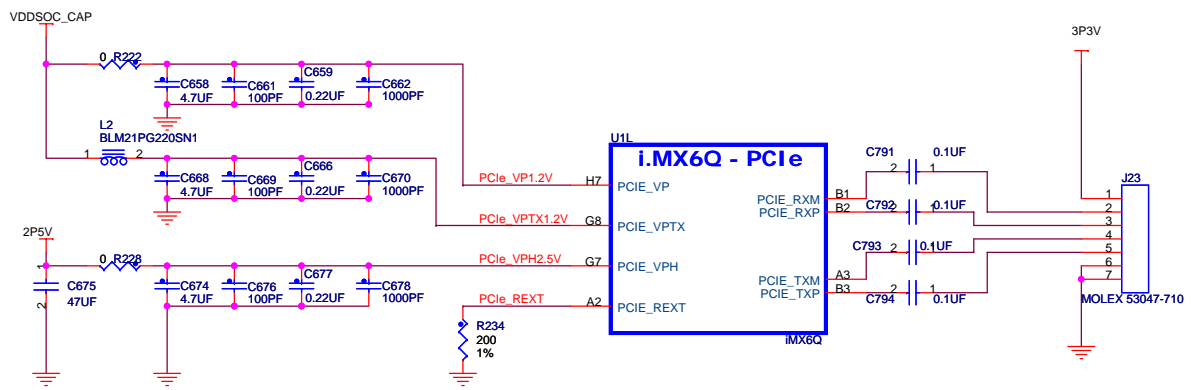

Design	<design>	element14		
Review	<review>			
Authorize	<authorize>	TitleSABRE Lite		
Standardize	<standardize>	Size	Doc Name	Ver.
		A3	07.IMX6Q_SOC_B	D
		Date	Friday, November 02, 2012	Sheet 7 of 17

DDR3 2GB (4GB option)

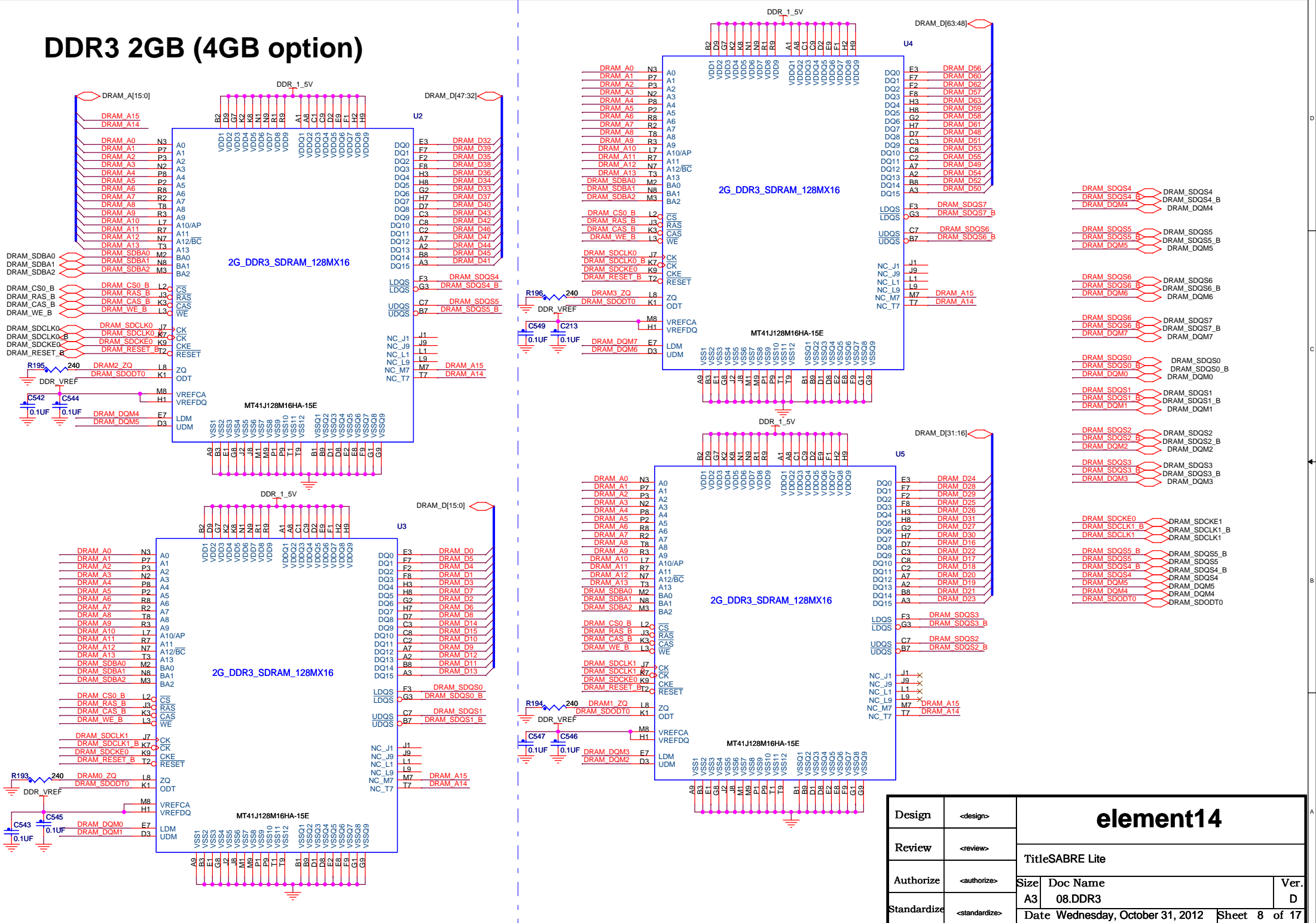

Design	<design>	element14		
Review	<review>			
Authorize	<authorize>	TitleSABRE Lite		
Standardize	<standardize>	Size	Doc Name	Ver.
		A3	08.DDR3	D
		Date	Wednesday, October 31, 2012	Sheet 8 of 17

USB HUB

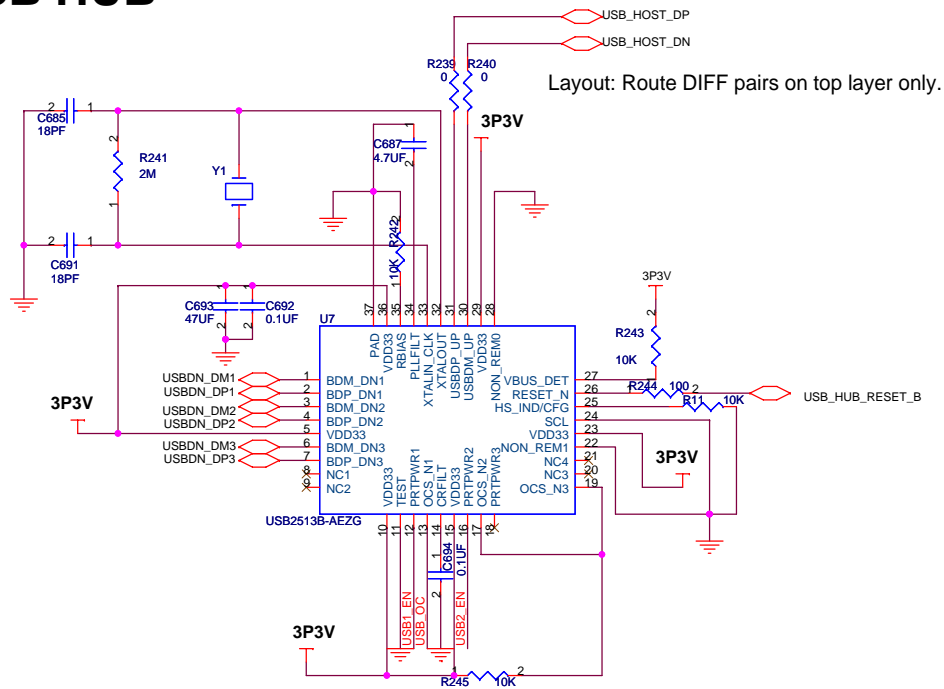

USB HOST

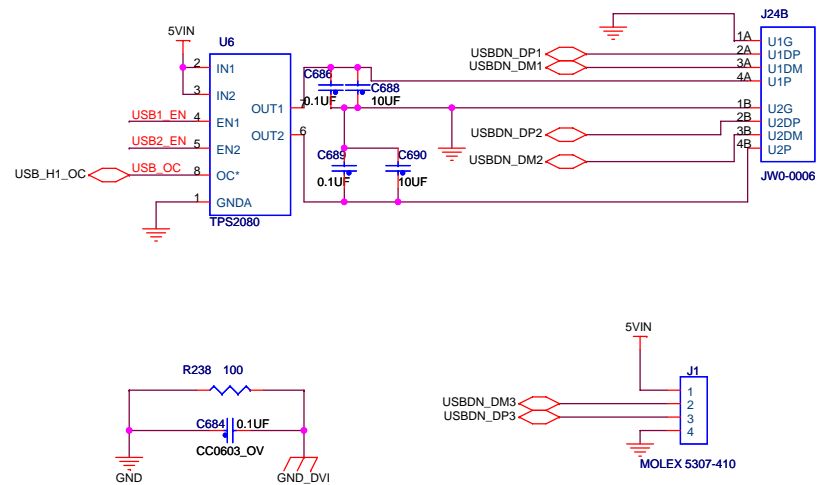

USB OTG

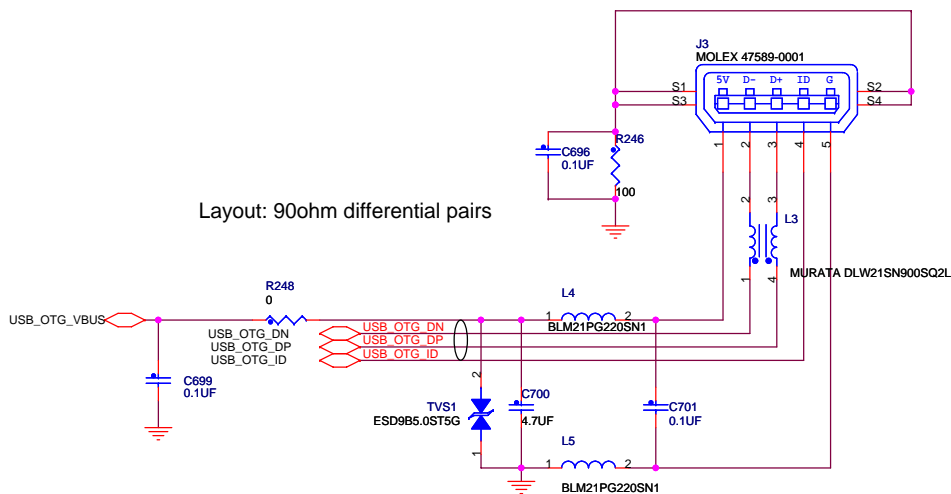

USB POWER SWITCH

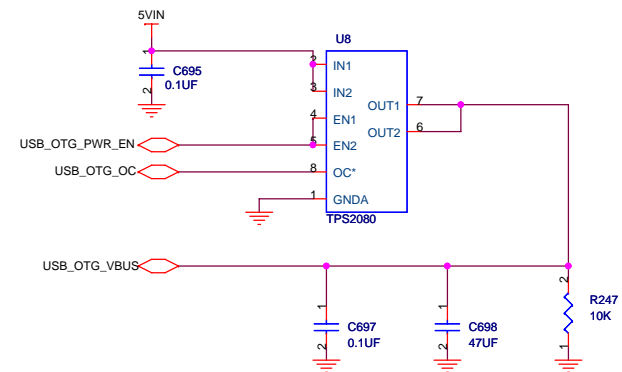

Design	<design>	element14		
Review	<review>			
Authorize	<authorize>	Title SABRE Lite		
Standardize	<standardize>	Size	Doc Name	Ver.
		A3	09.USB PORTS	D
		Date	Wednesday, October 31, 2012	Sheet 9 of 17

CMOS Sensor

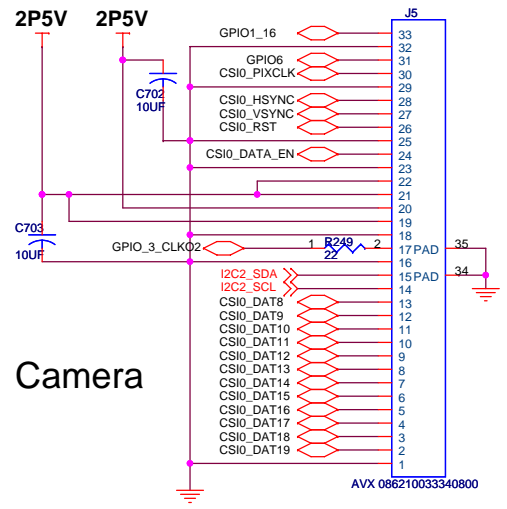

Camera

HDMI

Layout: HDMI 100 ohm differential pairs

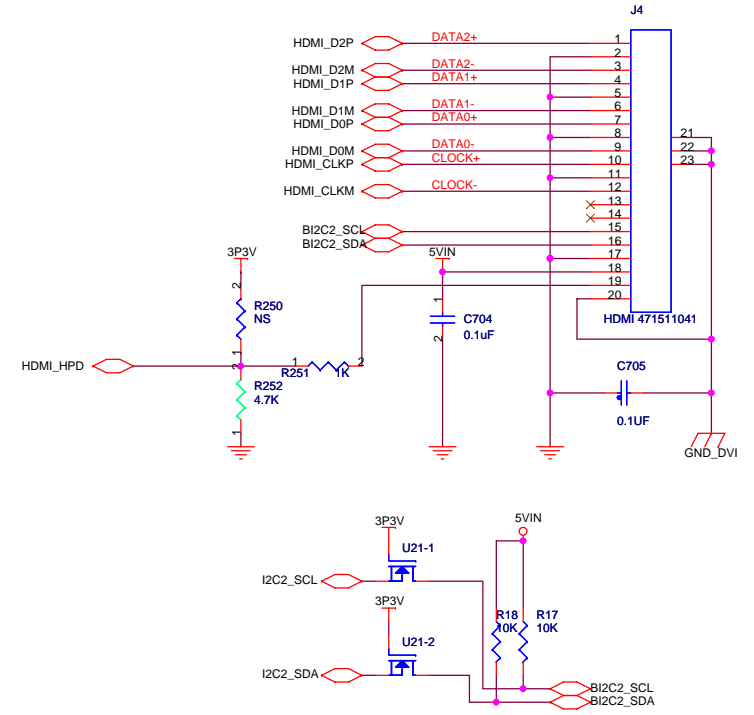

LVDS

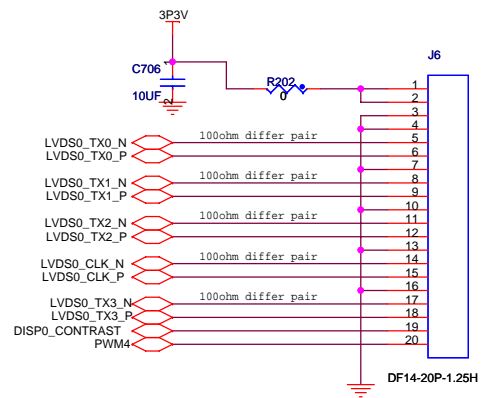

I2C FOR TOUCH

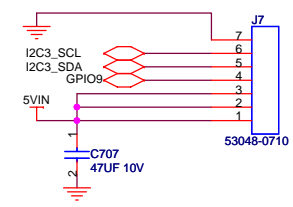

Design	<design>	element14		
Review	<review>			
Authorize	<authorize>	Size	Doc Name	Ver.
Standardize	<standardize>	A3	10.LVDS/HDMI/CAMERA	D
		Date	Wednesday, October 31, 2012	Sheet 10 of 17

AUDIO

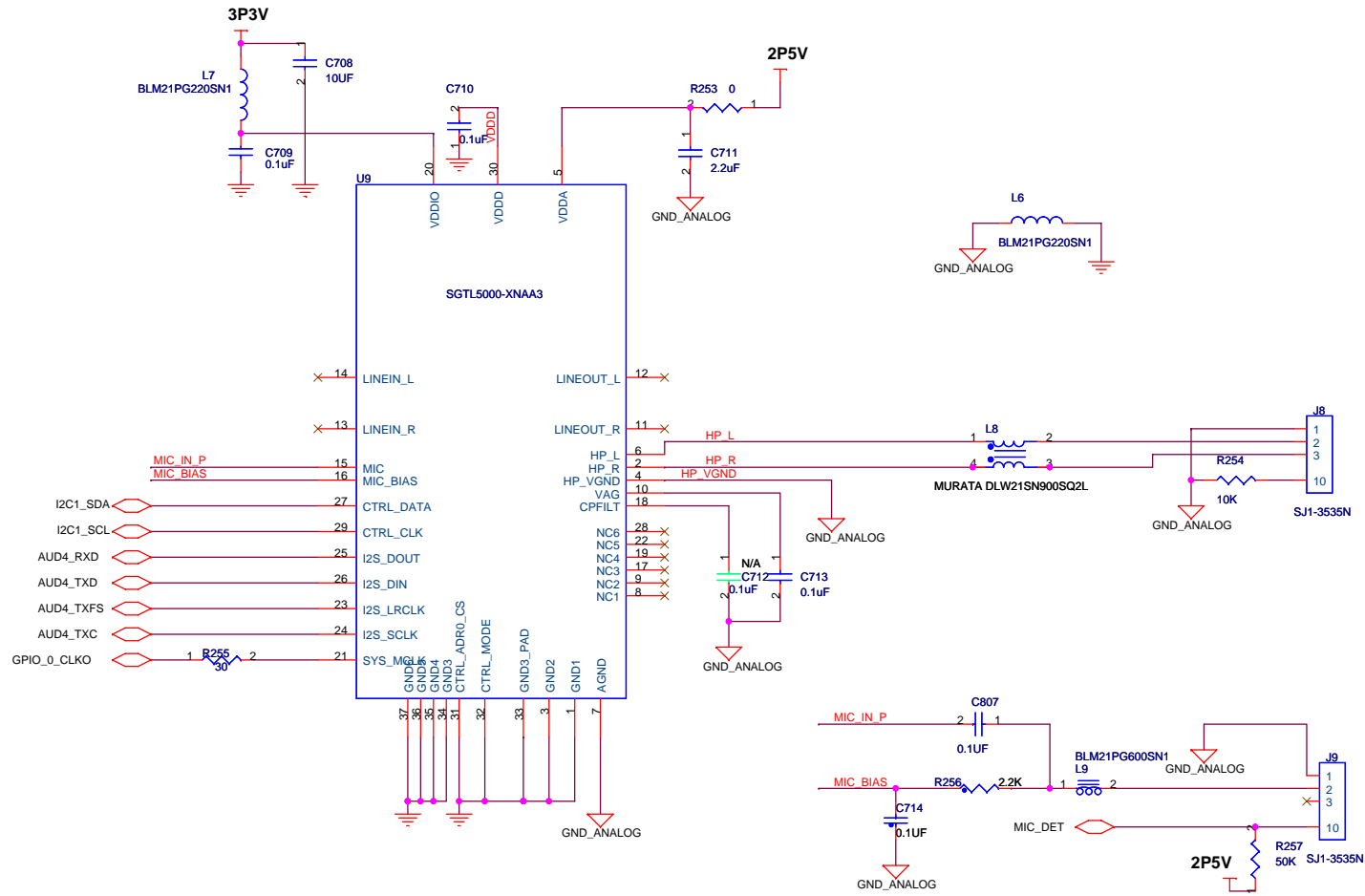

Design	<design>	element14		
Review	<review>			
Authorize	<authorize>	TitleSABRE Lite		
Standardize	<standardize>	Size	Doc Name	Ver.
		A3	11.MULTIMEDIA SGLT500	D
		Date	Wednesday, October 31, 2012	Sheet 11 of 17

SD/MMC CARD

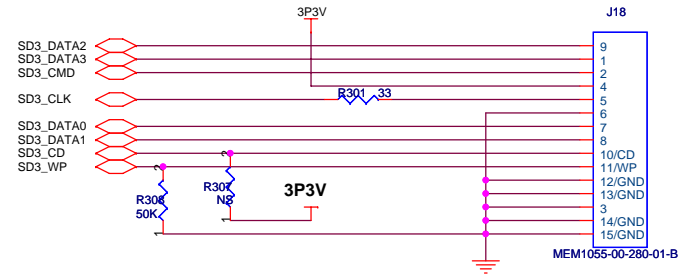

SPI FLASH

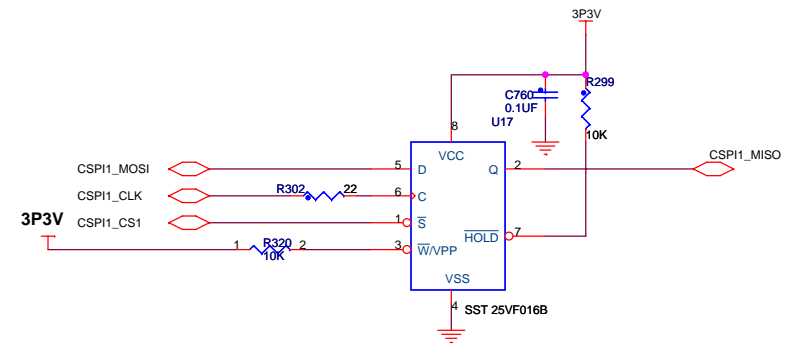

SATA

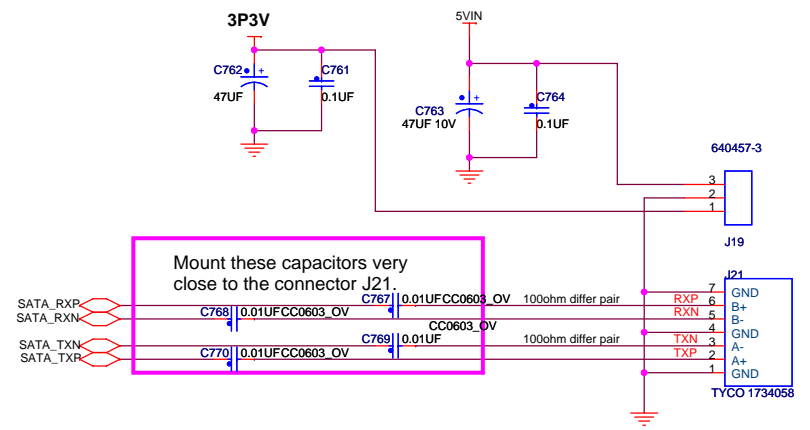
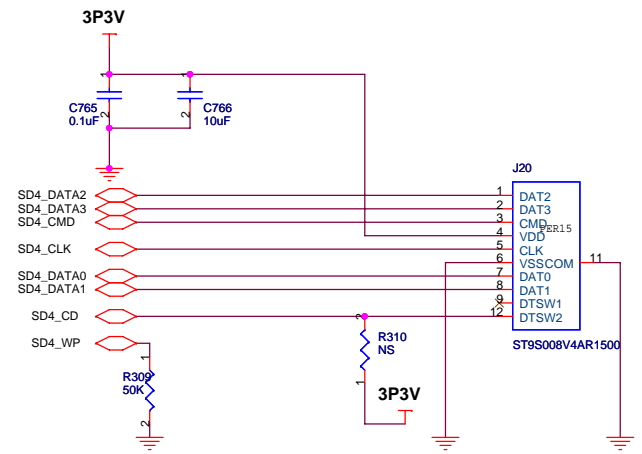

Layout:
50ohm, SD singals(SD_DATAx, SD_CMD, SD_CLK) length equal

Design	<design>	element14		
Review	<review>			
Authorize	<authorize>	Title SABRE Lite		
Standardize	<standardize>	Size	Doc Name	Ver.
		A3	12.MMC/SATA/SPI FLASH	D
		Date	Wednesday, October 31, 2012	Sheet 12 of 17

LAN

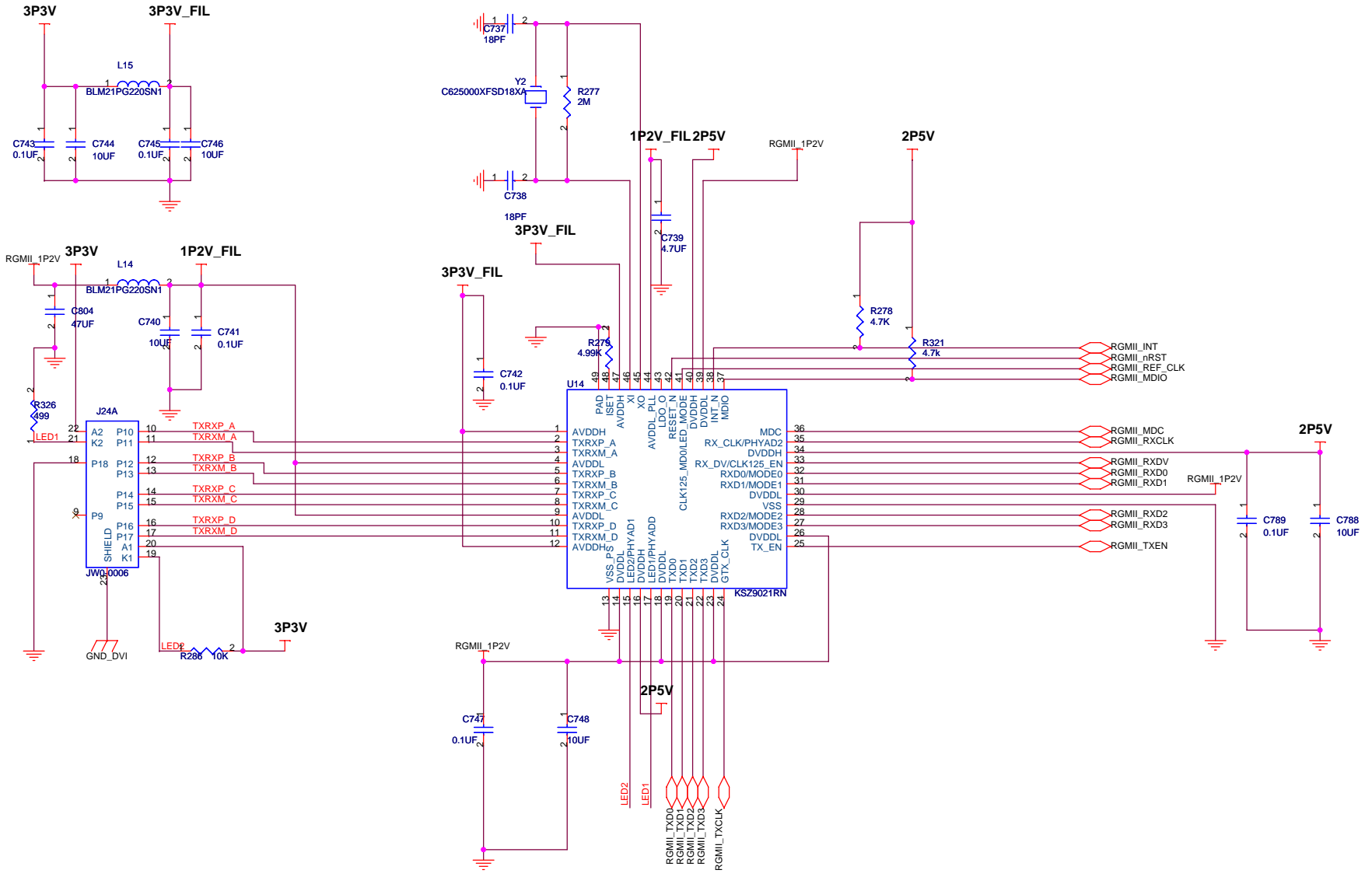

Design	<design>	element14		
Review	<review>			
Authorize	<authorize>	Title SABRE Lite		
Standardize	<standardize>	Size	Doc Name	Ver.
		A3	13.RGMII	D
		Date	Wednesday, October 31, 2012	Sheet 13 of 17

Boot Configuration Select

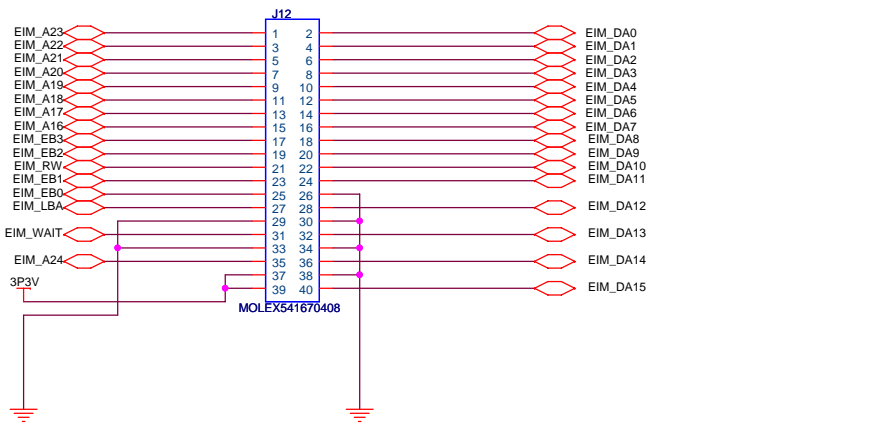

JTAG CONNECTOR

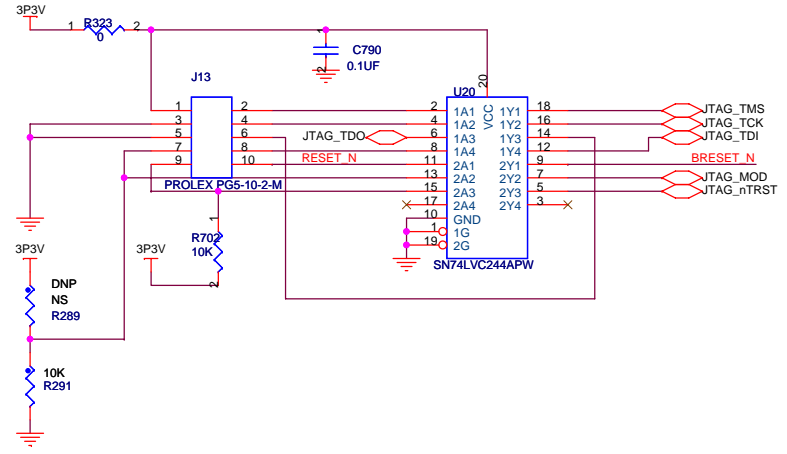

BOOT MODE

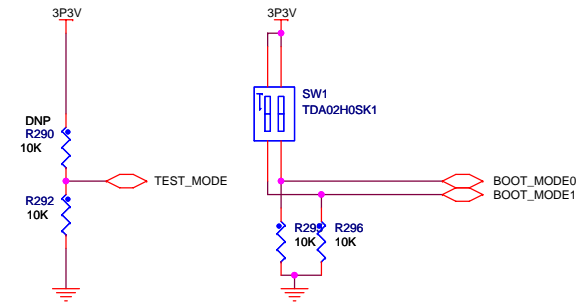

POWER MONITOR

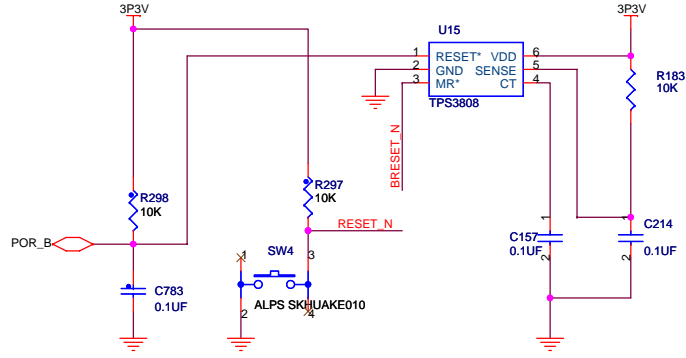

ANDROID BUTTONS

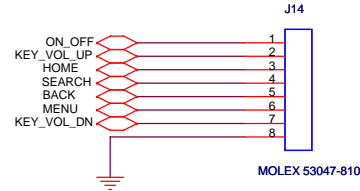

Design	<design>	element14		
Review	<review>			
Authorize	<authorize>	Title SABRE Lite		
Standardize	<standardize>	Size A3	Doc Name 14.DIAGNOSTIC/ALERT	Ver. D
		Date Wednesday, October 31, 2012	Sheet 14 of 17	

PARALEL RGB INTERFACE

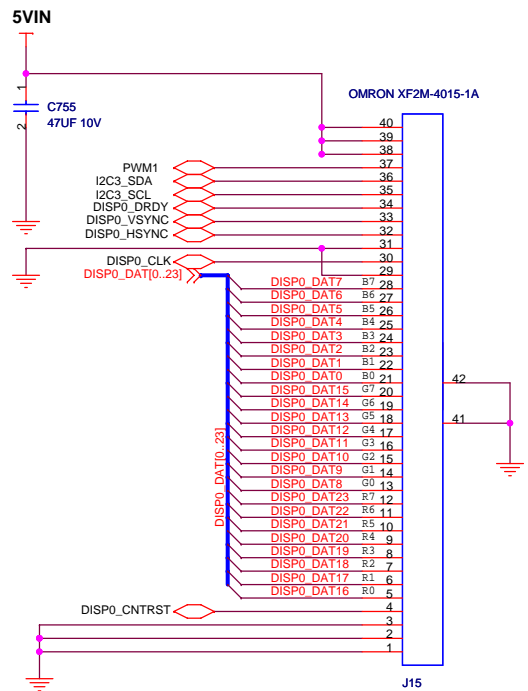

MIPI INTERFACE

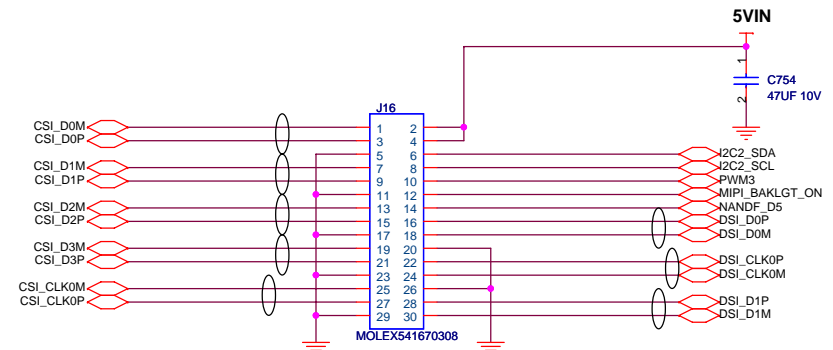

Layout: 100 ohm differential pairs

RS232 INTERFACE

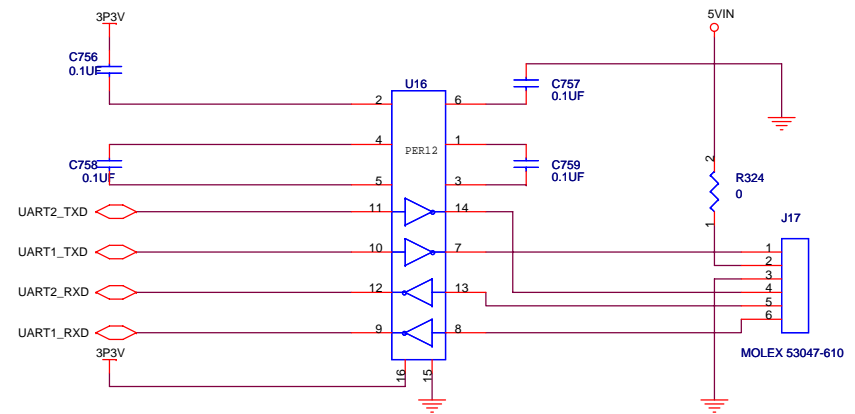

Design	<design>	element14		
Review	<review>			
Authorize	<authorize>	Title SABRE Lite		
Standardize	<standardize>	Size	Doc Name	Ver.
		A3	15.RGB DISPLAY MIPI UART	D
		Date	Wednesday, October 31, 2012	Sheet 15 of 17

CAN INTERFACE

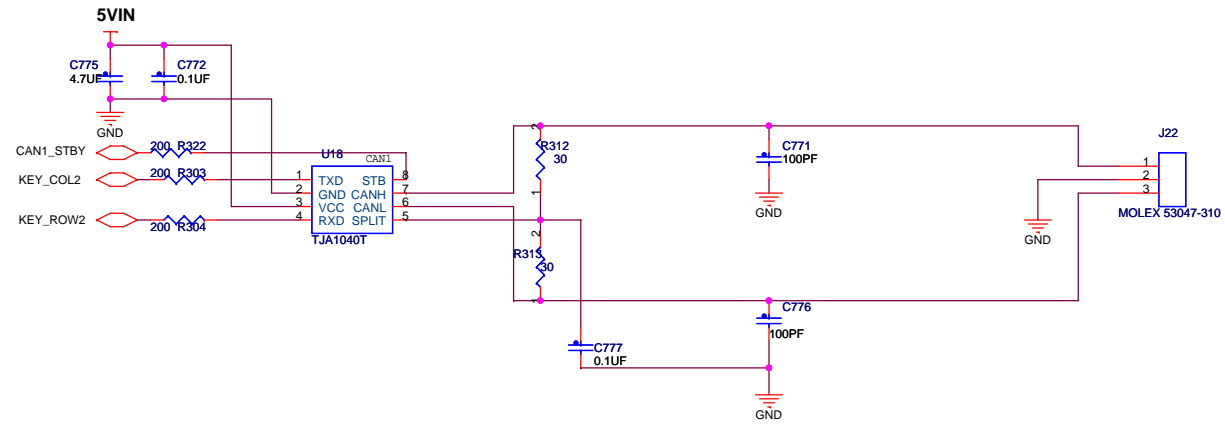

Design	<design>	element14		
Review	<review>			
Authorize	<authorize>	Size	Doc Name	Ver.
Standardize	<standardize>	A3	16.CAN BUS	D
		Date	Wednesday, October 31, 2012	Sheet 16 of 17

POWER DDR 1.5V

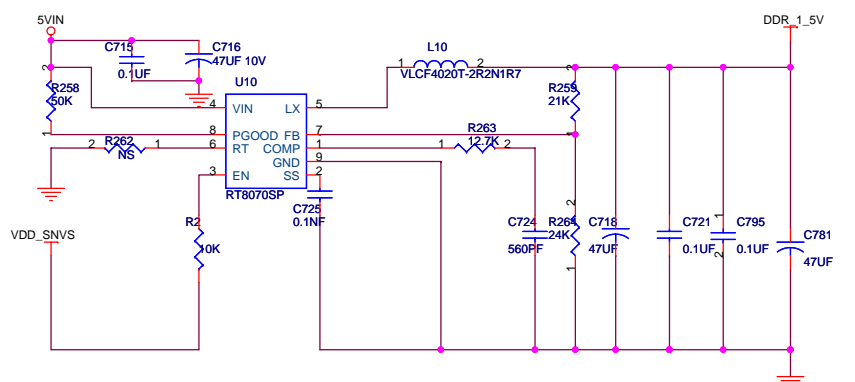

POWER 1.2V

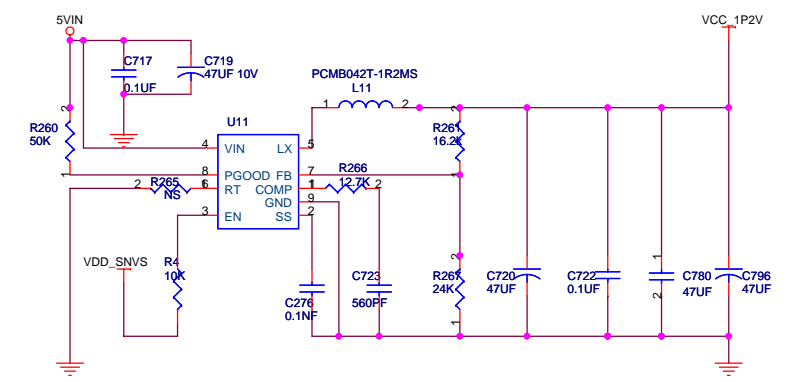

POWER 3.3V

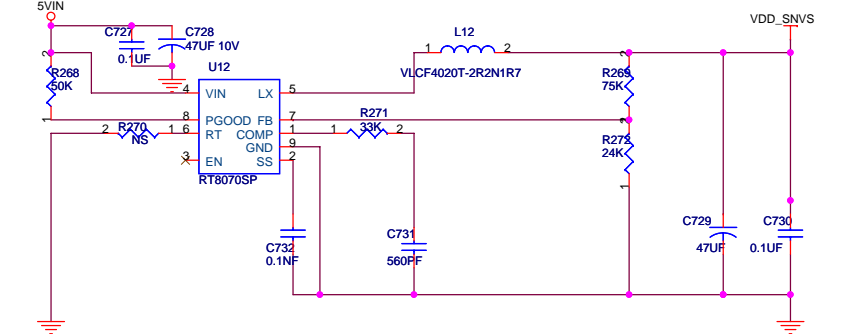

POWER 3.3V

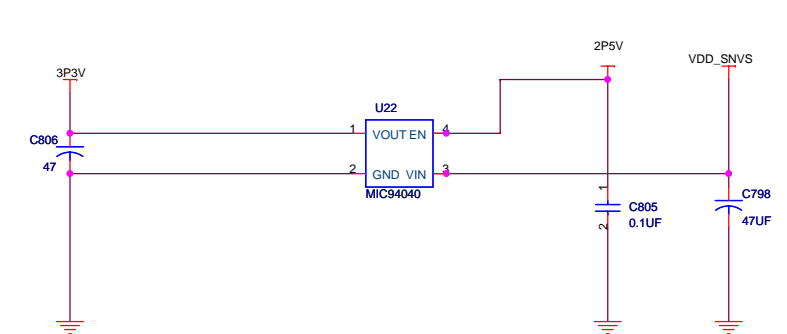

POWER 2.5V

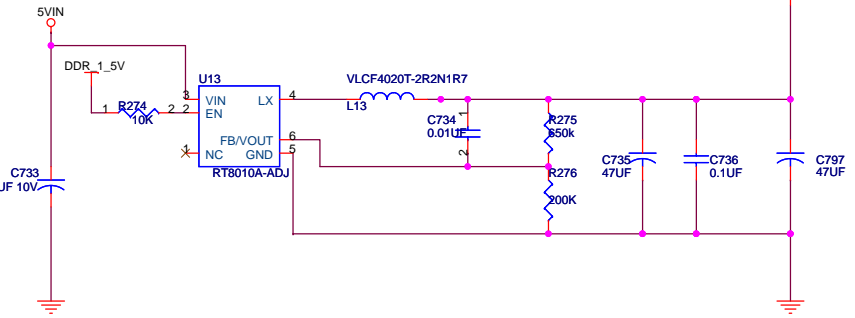

NI

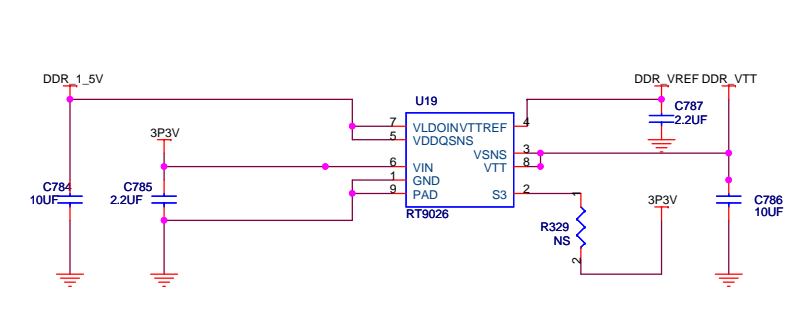

POWER INPUT



Design	<design>	element14		
Review	<review>			
Authorize	<authorize>	Title SABRE Lite		
Standardize	<standardize>	Size	Doc Name	Ver.
		A3	17.SYSTEM POWER	D
		Date	Wednesday, October 31, 2012	Sheet 17 of 17