

6

5

4

3

2

1

REVISION RECORD

LTR	ECO NO:	APPROVED:	DATE:

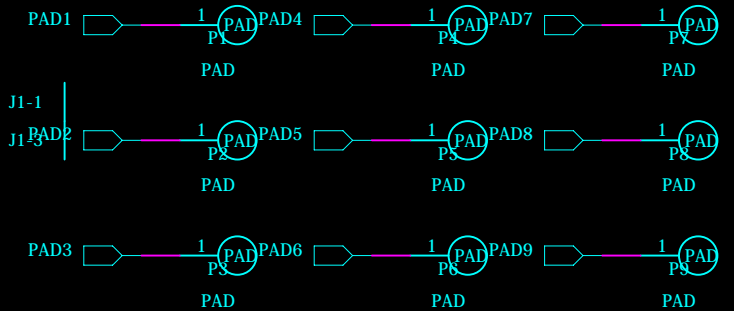
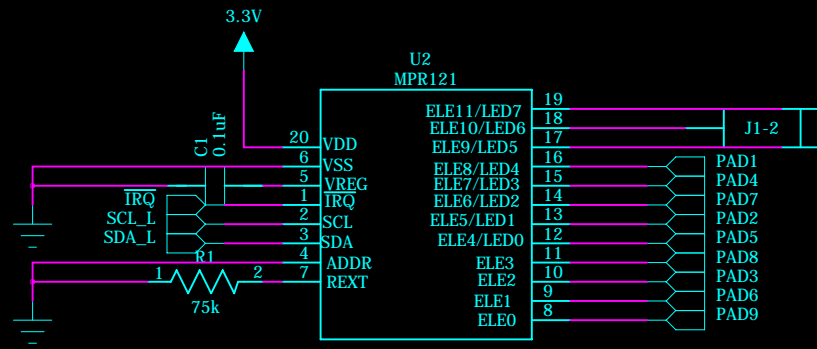
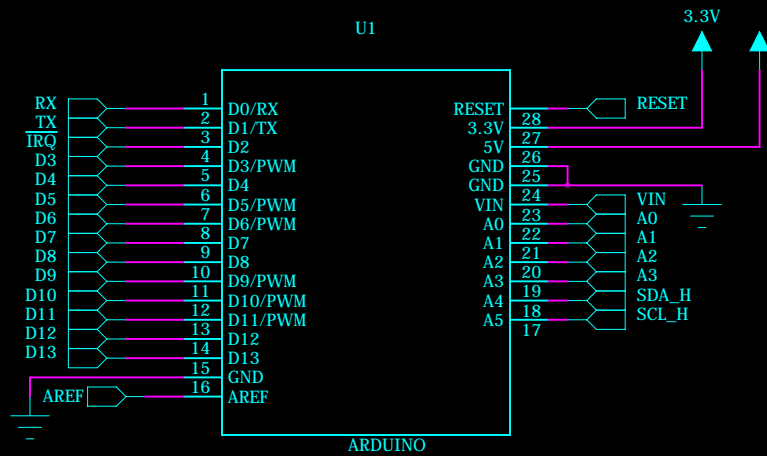
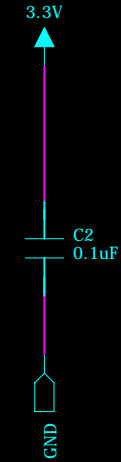
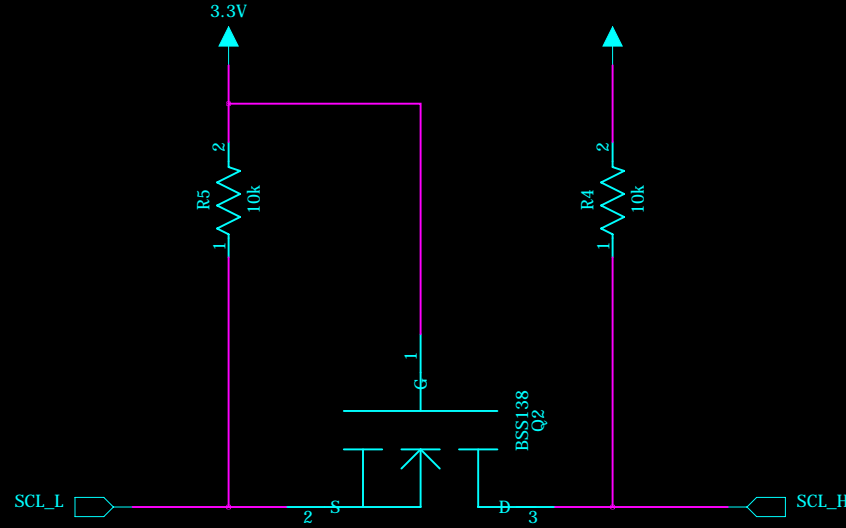
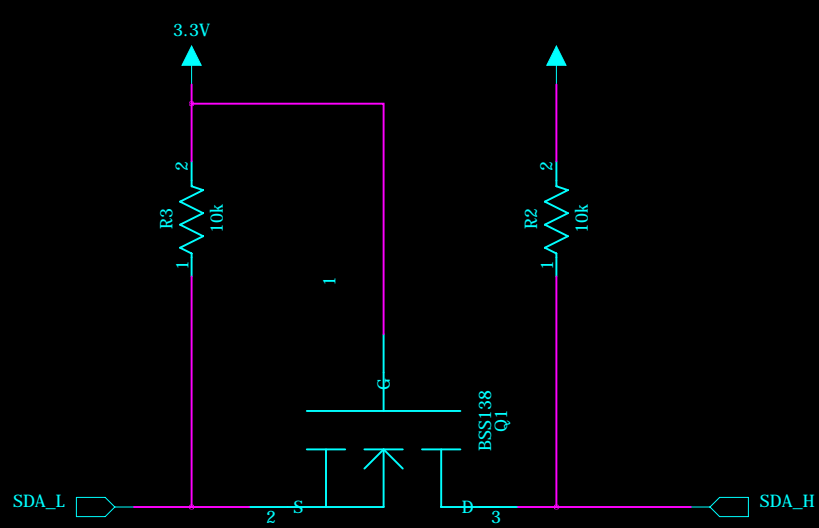

COMPANY: **Soliddigital**

TITLE: **Touch Shield**

DRAWN: yu.hongwei	DATED: <Drawn Date>	CODE: <Code>	SIZE: A3	DRAWING NO: <Drawing Number>	REV: Ver1.0
CHECKED: <Checked By>	DATED: <Checked Date>	SCALE: <Scale>			
QUALITY CONTROL: <QC By>	DATED: <QC Date>	SHEET: 1 OF 1			
RELEASED: <Released By>	DATED: <Release Date>				

D

D

C

C

B

B

A

A